

**3D Tutorials
AutoCAD 2009**

Written by Kristen Kurland

Copyright © 2008

AutoCAD 3D – Chapter 1
3D Interface

AutoCAD 3D Tutorial

1.1 Launching AutoCAD 3D

1. Choose **Start** from the Windows program manager.
2. Choose **Programs, Autodesk ,AutoCAD 2009.**

Workspaces

AutoCAD workspaces are sets of menus, toolbars and dockable windows (such as the Properties palette, DesignCenter, and the Tool palettes window) that are grouped and organized so that you can work in a custom, task-oriented drawing environment.

1. Click the Workspace Switching icon.



2. Click **3D Modeling** and **OK.**

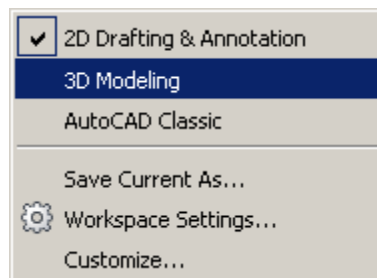

AutoCAD 3D Tutorial

1.2 3D Interface

AutoCAD's 3D Interface consists of three main areas

Panels

Anchored palettes

A 3D workspace

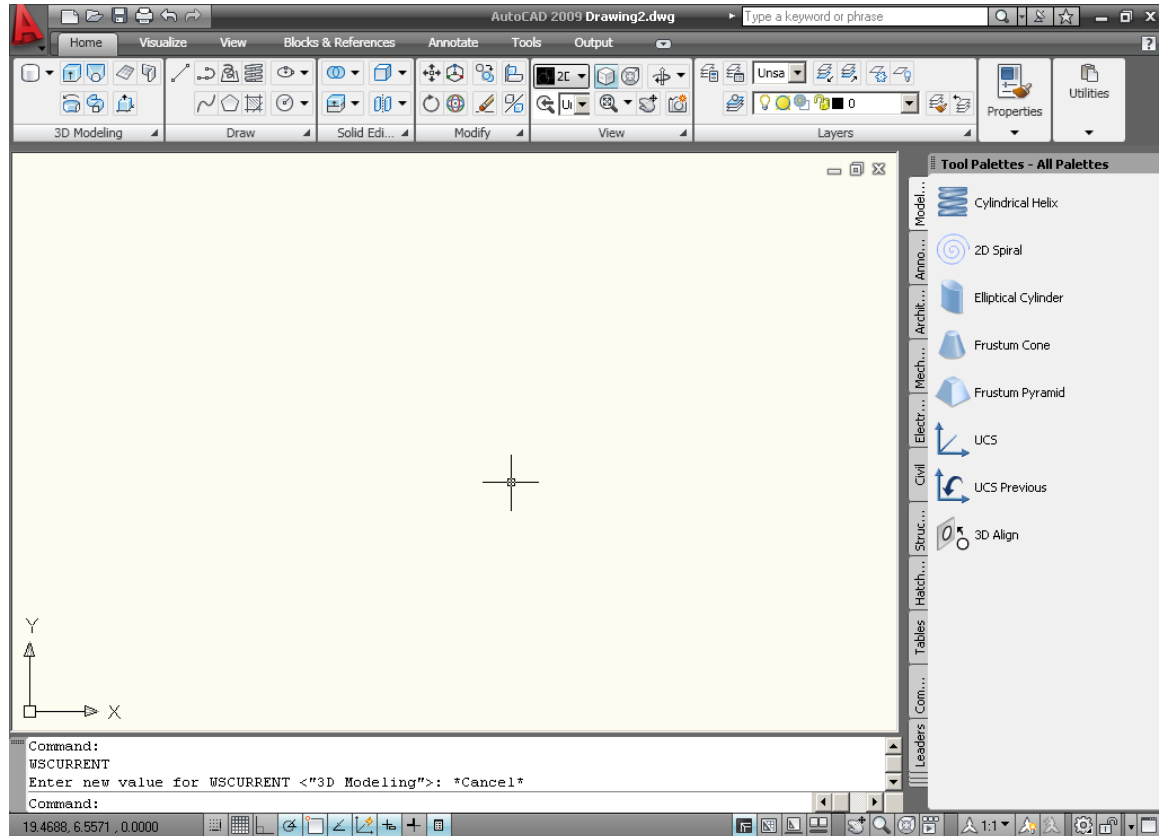

AutoCAD 3D Tutorial

1.3 3D Dashboard

The dashboard consists of a set of control panels organized by function.

For example, the top control panel contains commands that create and modify 3D solids; the second control panel contains commands and controls used to navigate 3D models.

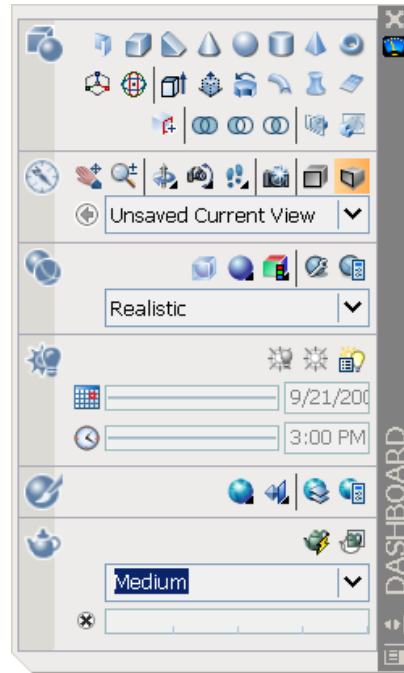

1. Click on one of the panels to expand the display to show a slide-out panel that has additional controls.

Click to expand dashboard panel

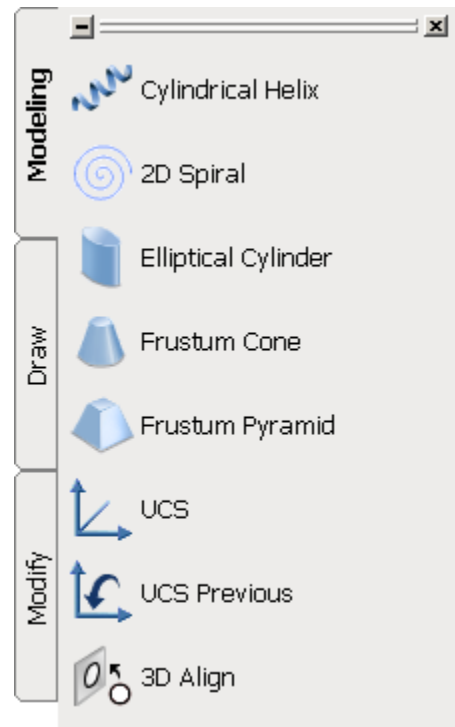
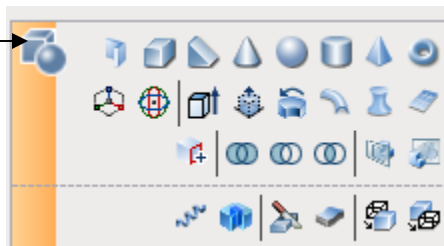

AutoCAD 3D Tutorial

1.4 Viewports

1. Choose **View, Viewports, 4 Viewports.**

or

2. Type -VPORPTS at the command prompt.

Command: **-VPORPTS**

Enter an option [Save/Restore/Delete/Join/Single/?/2/3/4] **4: enter**

Enter a configuration option [Horizontal/Vertical/Above/
Below/Left/Right] <Right>: **enter**

Your screen will look something like the figure below with four views in one AutoCAD drawing.

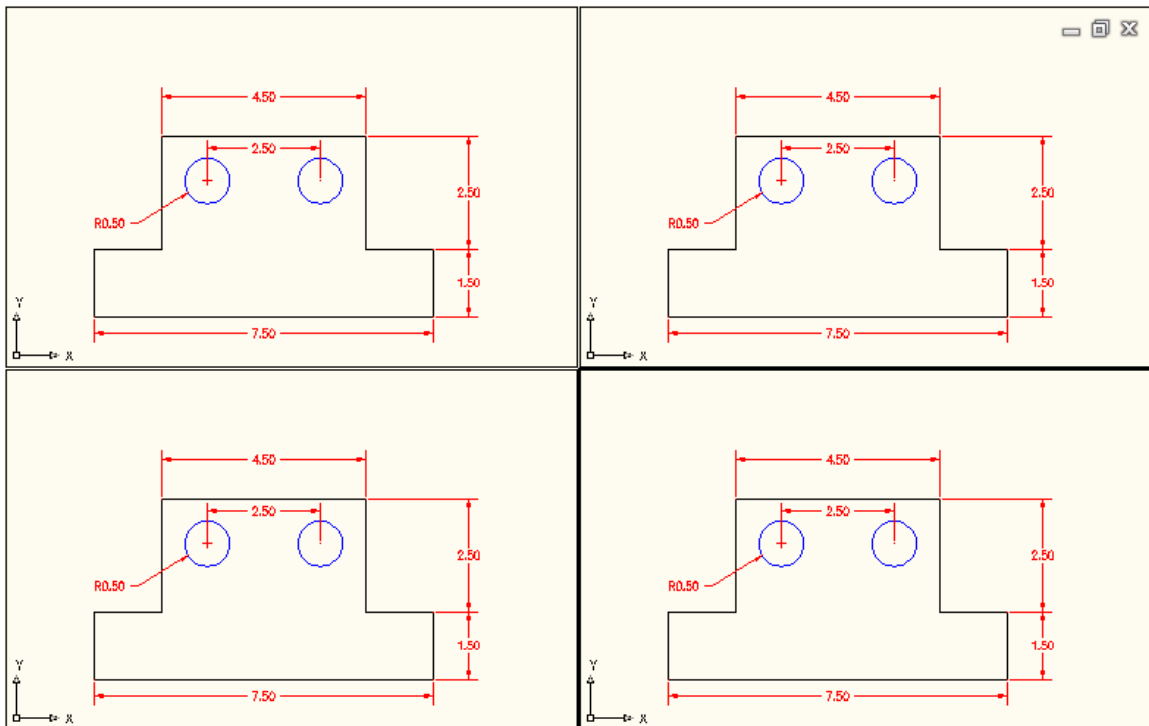

AutoCAD 3D Tutorial

1.5 Preset 3D Viewports

1. Choose **View, Viewports, New Viewports**
2. Click the dropdown option for **Setup** and click **3D**.
3. Choose **Four: Right** as the viewport option.

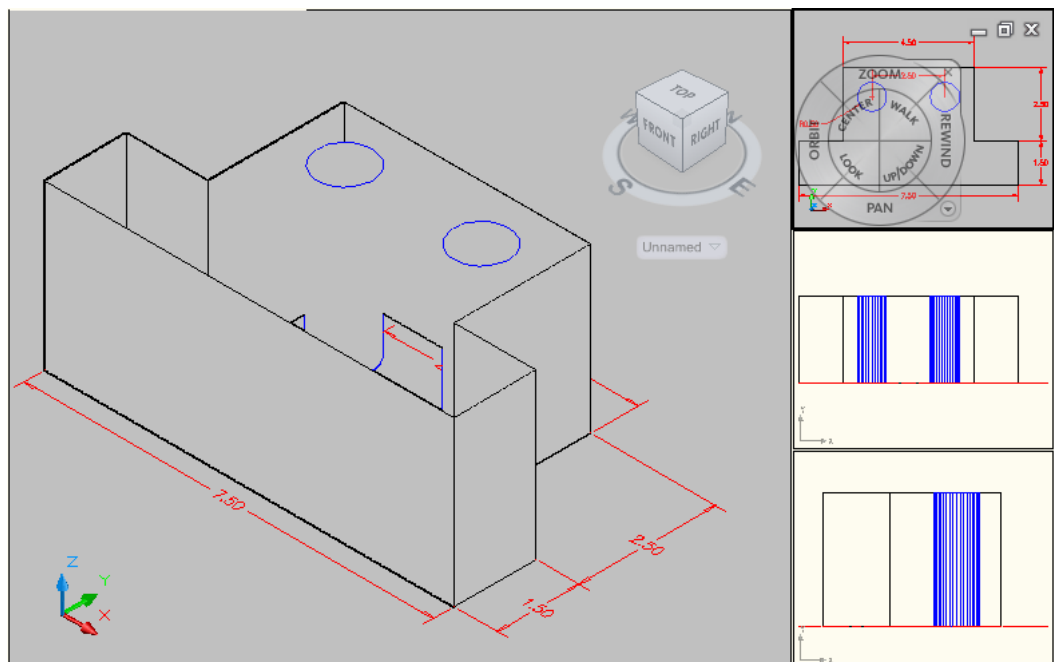
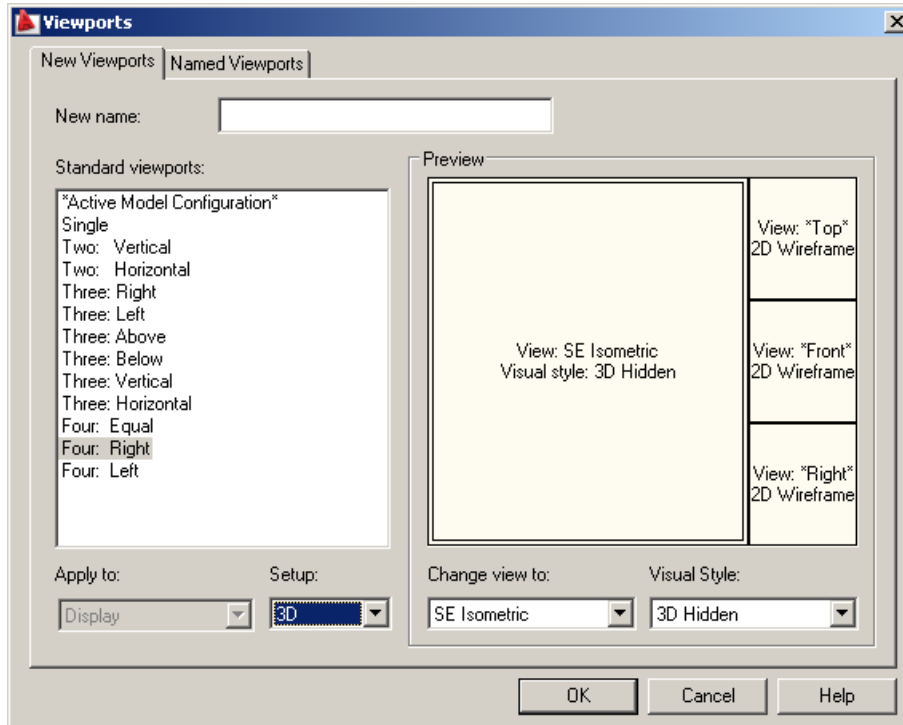

AutoCAD 3D Tutorial

1.6 Named Views

1. Choose View, Named Views...
2. Click the plus (+) sign beside **Preset Views**.
3. Click **NE Isometric**, **Set Current**, **Apply**, and **OK**.

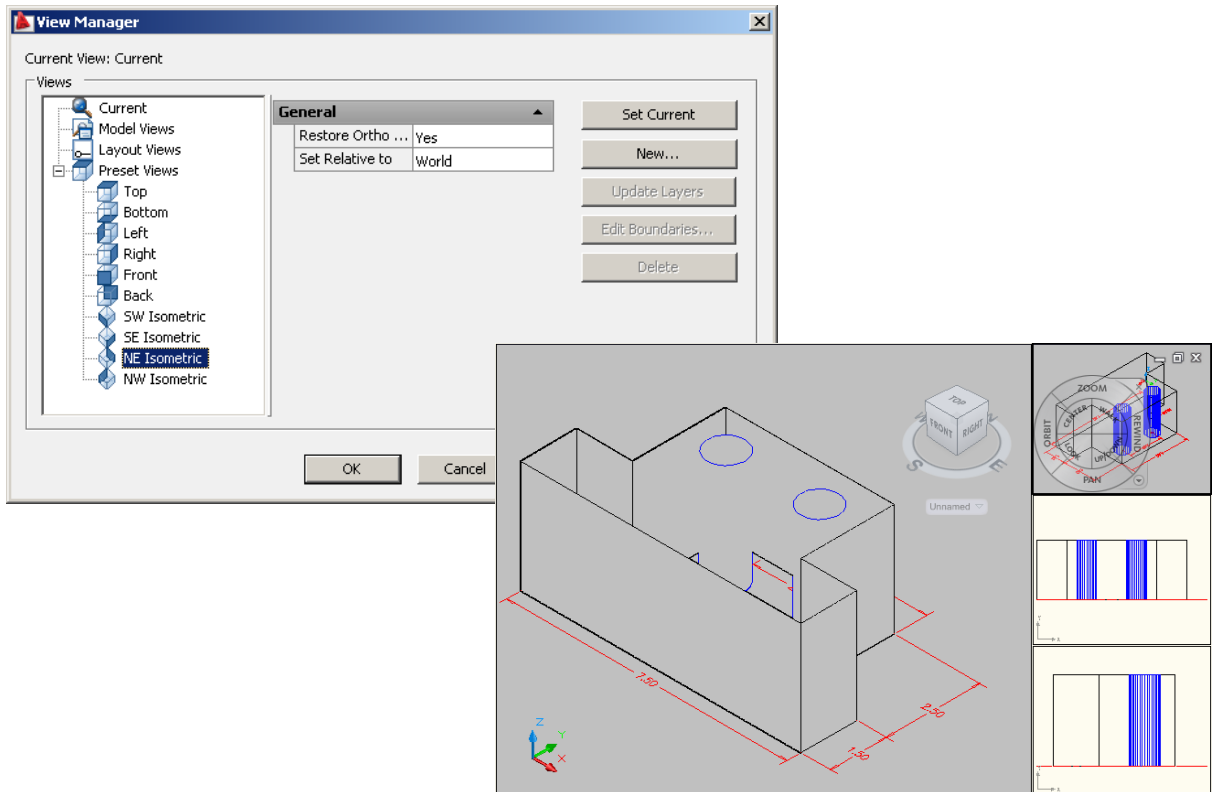

Tip:

You can also choose View, 3D Views, and any of the preset 3D views.

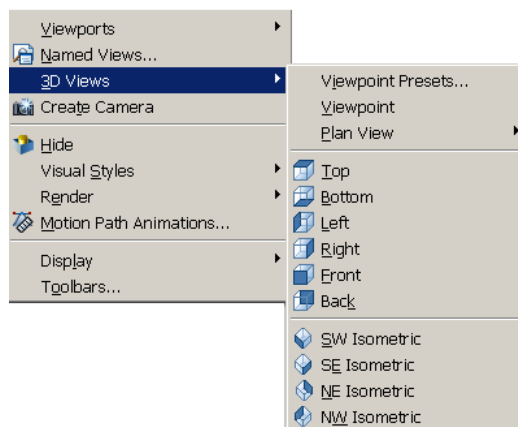

AutoCAD 3D Tutorial

1.7 Steering Wheel

SteeringWheels are menus that track the cursor over the drawing window, and provide access to 2D and 3D navigation tools from a single interface.

SteeringWheels, or “wheels,” are divided into wedges; each wedge contains a single navigation tool. You can start a navigation tool by clicking a wedge or by clicking and dragging the cursor over a wedge..

2D Navigation Wheel (Zoom & Pan)

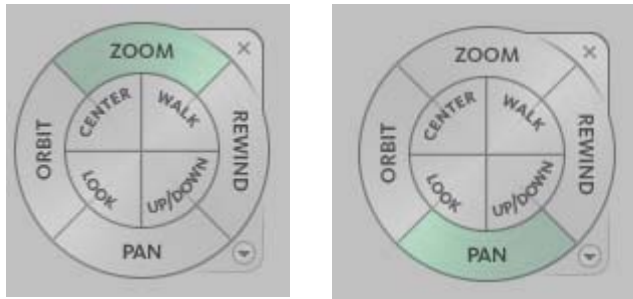

View Object Wheel – Center a model and define the pivot point to use with the Orbit tool. Zoom and orbit a model.

Center

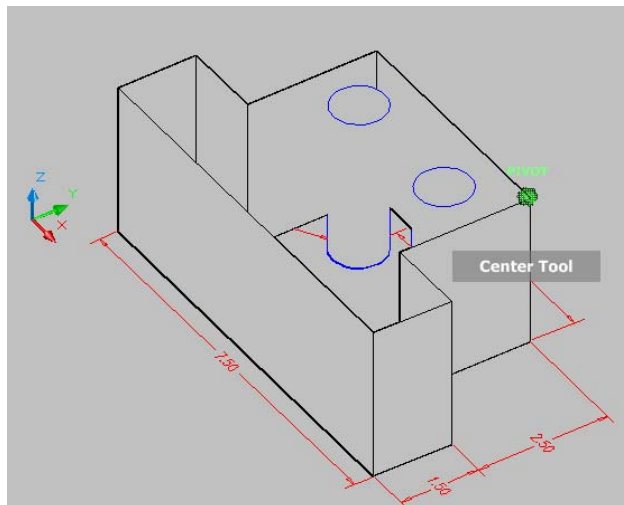
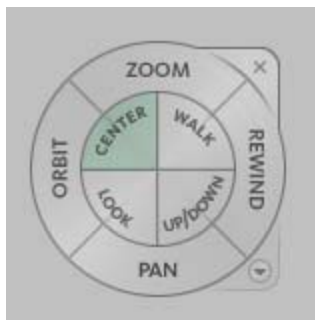

AutoCAD 3D Tutorial

Orbit

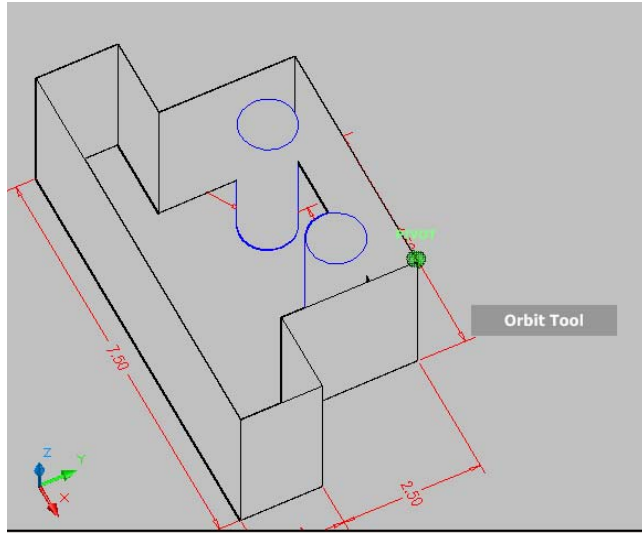

Look



AutoCAD 3D Tutorial

Walk/Up/ Down

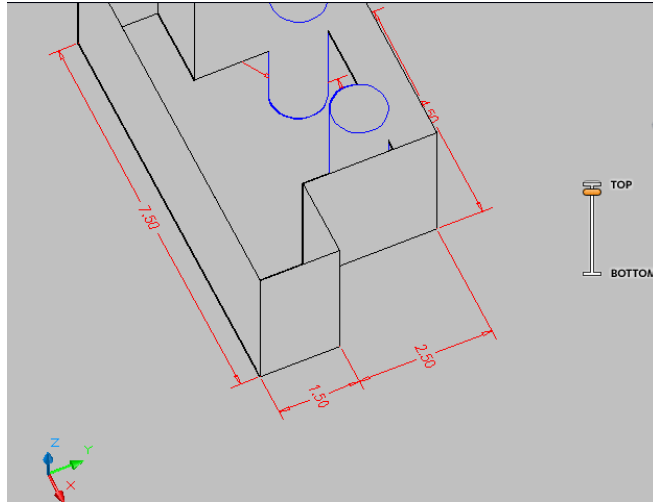

Rewind

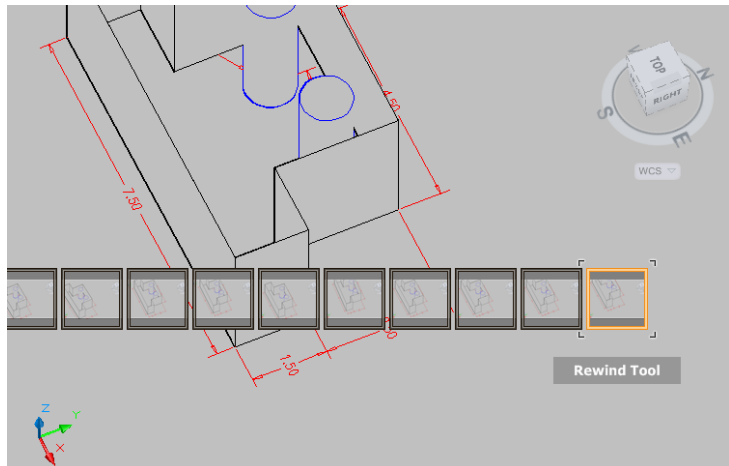

Shortcuts



AutoCAD 3D Tutorial

Steering Wheel Settings

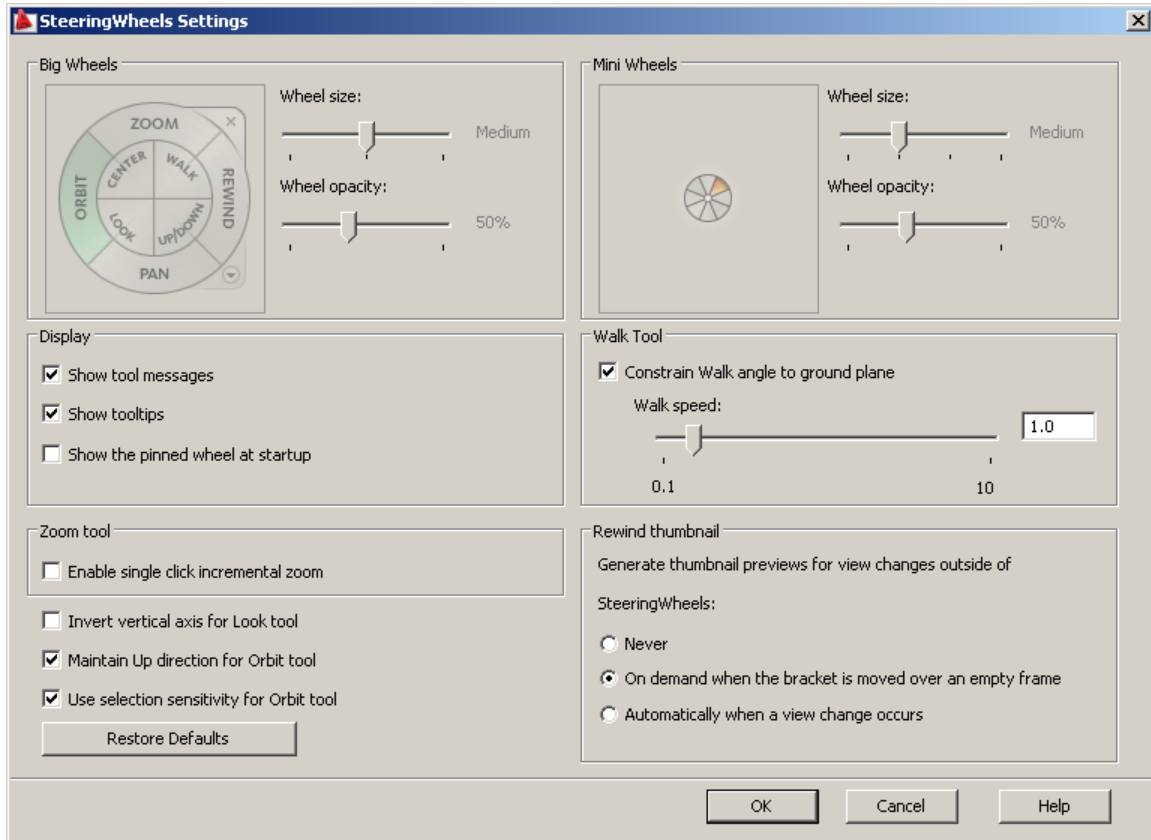

AutoCAD 3D Tutorial

1.8 VPOINT Command (Tripod)

Displays a compass and tripod for defining a view rotation. The compass represents a two dimensional globe.

1. **Choose** View, 3D Views, point
or

2. **Type** VPOINT at the command
prompt.

Command: **vpoint**

Rotate/<Viewpoint><-0.614,-0.614,0.500>:
(enter)

3. **Click** a point on the compass to define the viewing angle.

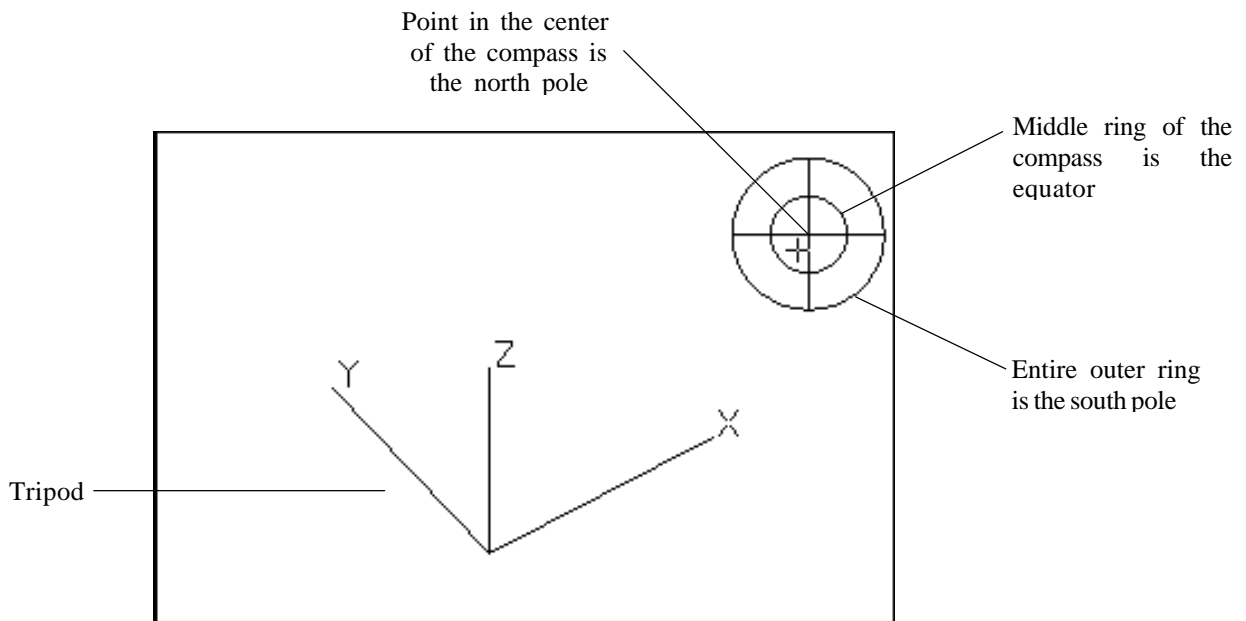

AutoCAD 3D Tutorial

1.9 VPOINT Command (Rotate)

Enters a rotation angle at the viewpoint prompt.

1. Type VPOINT at the command prompt.

Command: **vpoint**

Rotate/<View point> <-0.614,-0.614,0.500>: **R (enter)**

Enter angle in XY plane from X axis <225>: **225 (enter)**

Enter angle from XY plane <30>: **15 (enter)**

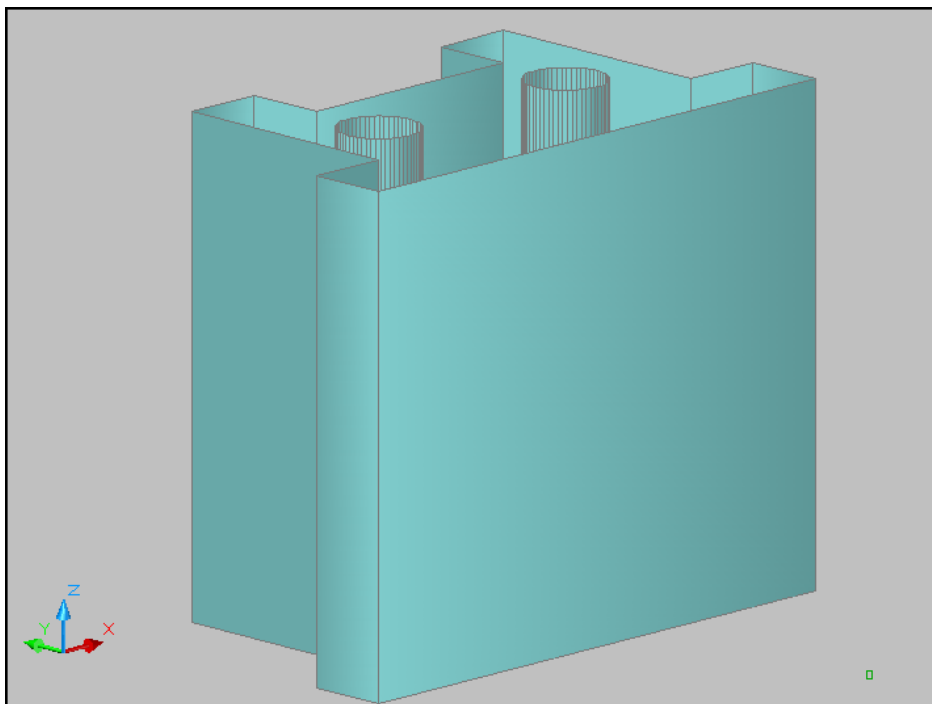

AutoCAD 3D Tutorial

1.10 DDVPOINT

1. Choose **View, 3D Views, Viewpoint Preset**.

or

2. Type DDVPOINT at the command prompt.

Command: **ddvpoint**

3. Set a viewing angle by typing the From X axis and XY Plane angle.

or

4. Pick a viewing angle in the 2 graphics Left graphic = From X Axis

Right graphic = In XY Plane

5. Click **OK**.

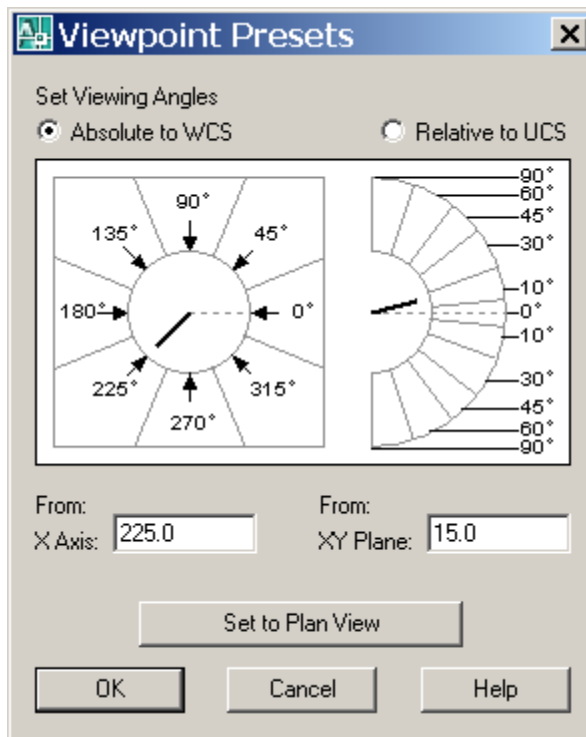

AutoCAD 3D Tutorial

1.11 Plan View

1. Choose **View, 3D Views, Plan View** the one of the following:
Current UCS, World UCS, Named UCS

or

2. Type PLAN at the command prompt.

Command: **plan**

Enter an option [Current Ucs/Ucs/World] <Current>: **World**

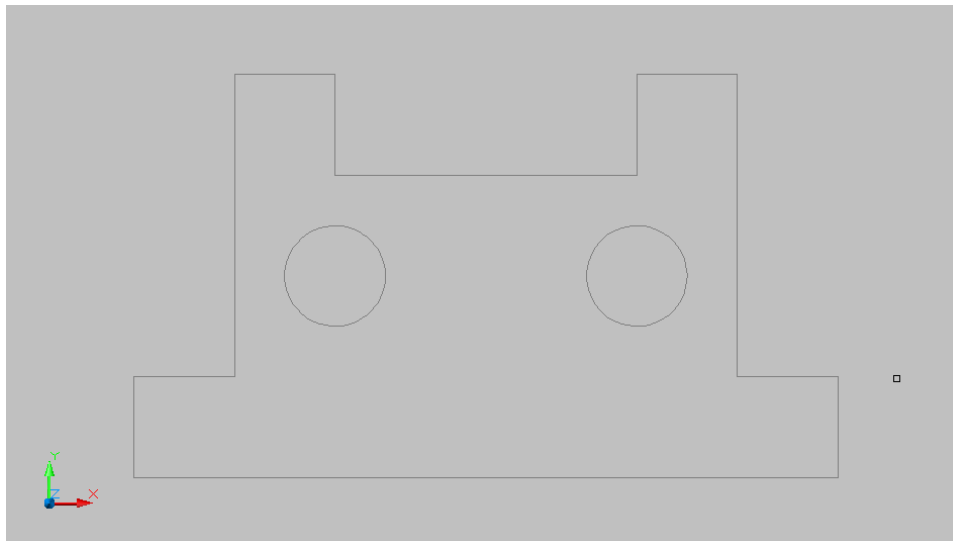

**AutoCAD 3D – Chapter 2
Thickness and Elevation**

AutoCAD 3D Tutorial

2.1 Thickness Command

1. Begin a new drawing using a 3D Modeling workspace.
2. Choose View, Viewports, 2 Viewports.
3. Press **ENTER** for the default of two vertical viewports.
4. In the left viewport, type **PLAN** and **World**.
5. Type THICKNESS at the command prompt.
Command: **thickness**
Enter new value for THICKNESS <0.0000>: **3**
6. In the plan view, draw a rectangle using in the LINE command.

The lines will have a 3D “thickness” that can be seen in the 3D view.

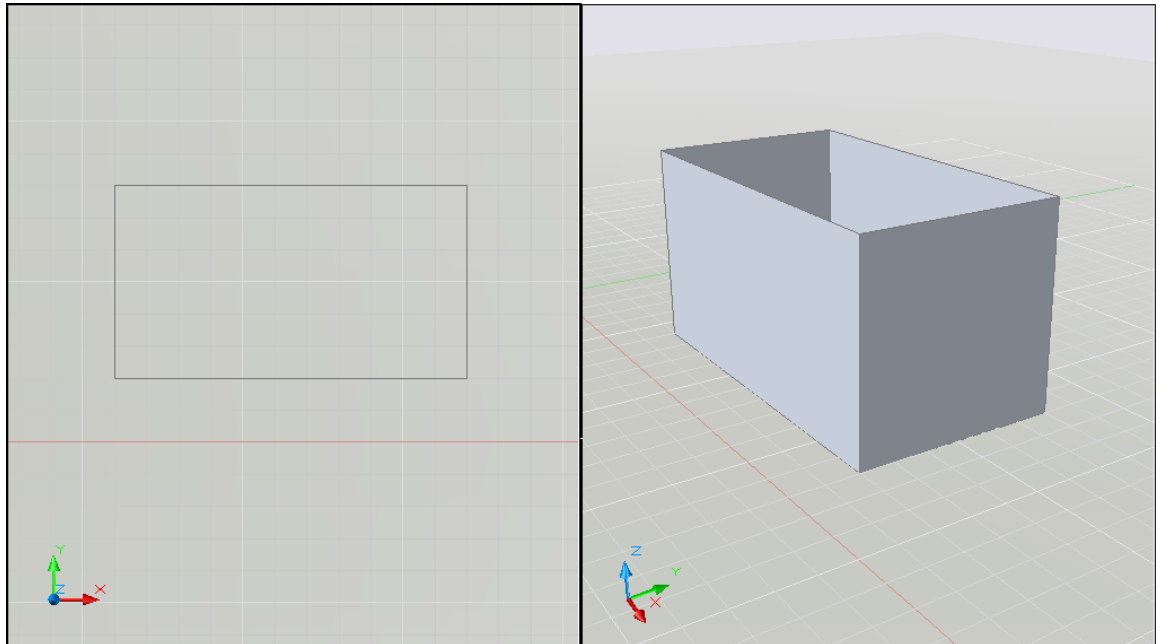

AutoCAD 3D Tutorial

2.2 Change Existing Thickness

1. Select the object whose thickness you would like to change (e.g. one line of the rectangle you drew in 2.1).
2. Choose **Modify, Properties...** or right click and choose Properties...
3. In the Properties dialog box type a new line thickness.

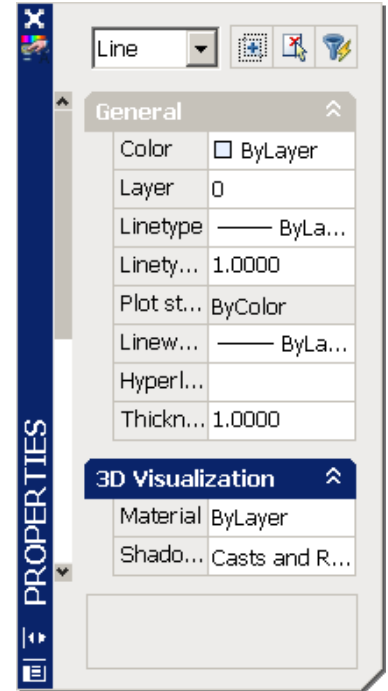

The following result is a new line thickness for the selected object.

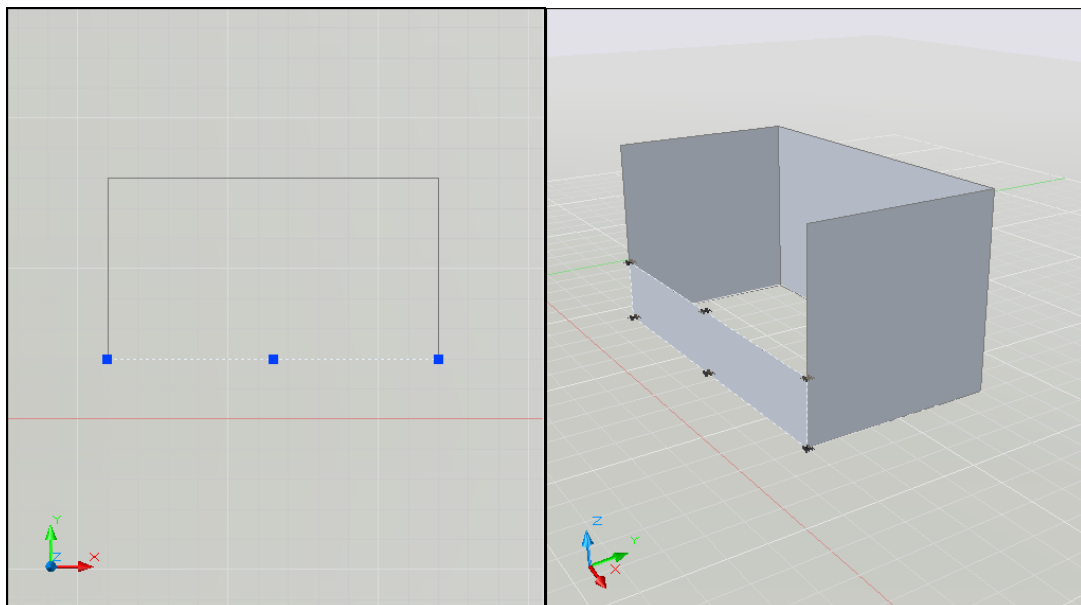

AutoCAD 3D Tutorial

2.3 Elevation

Stores the elevation for new objects relative to the current UCS for the current space.

1. Type ELEVATION at the command prompt.

Command: **elevation**

Enter new value for ELEVATION <0.0000>: **1.00**

2. Draw two circles at the new elevation. Note that they appear to be “floating” 1 unit above the ground.

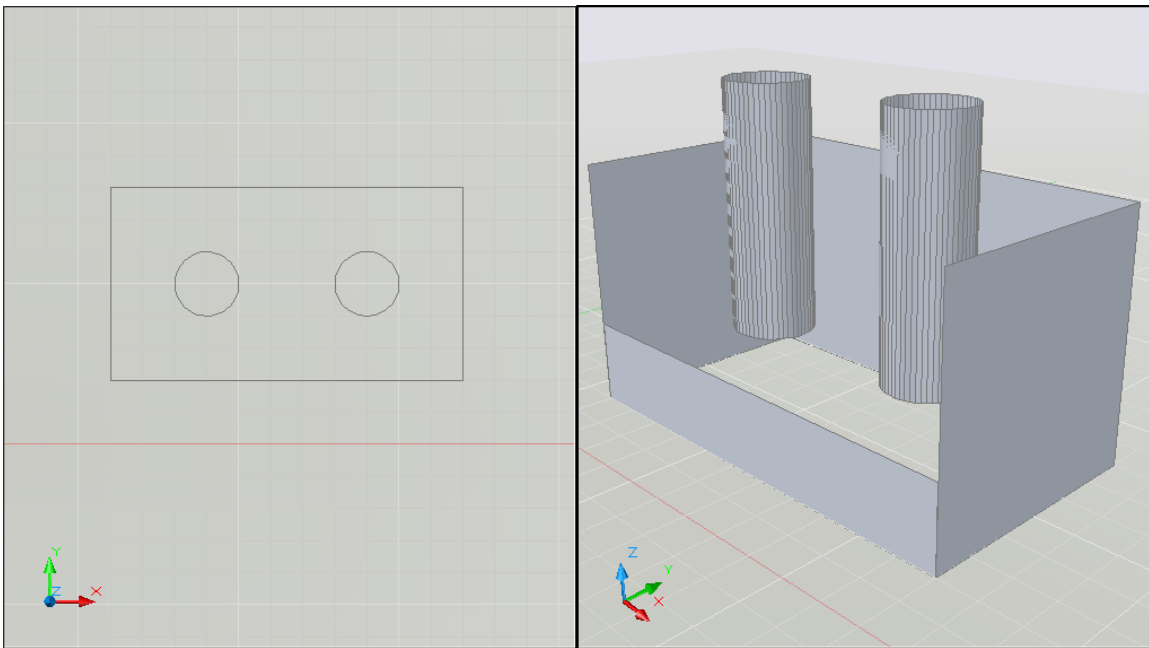

AutoCAD 3D Tutorial

2.4 Elevation Shortcut

1. Type ELEV at the command prompt.

Command: **elev**

Specify new default elevation: <1.0000>: **1**

Specify new default thickness: <3.000>: **1**

2. Draw a new line to see the elevation and thickness settings.

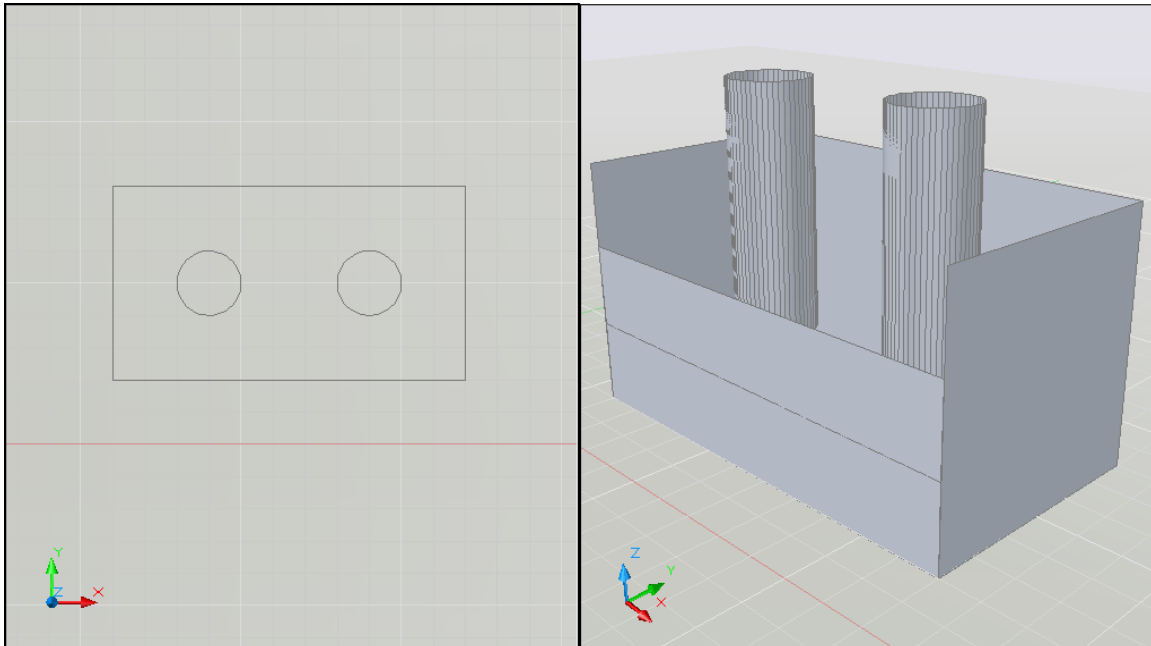

**AutoCAD 3D – Chapter 3
Visualizing Your Model**

AutoCAD 3D Tutorial

3.1 HIDE Command

Regenerates a three-dimensional model with hidden lines

1. Open a drawing with 3D objects and display in a 3D view.
2. Choose **View, Hide.**
or
3. Type HIDE at the command prompt.
Command: **hide**

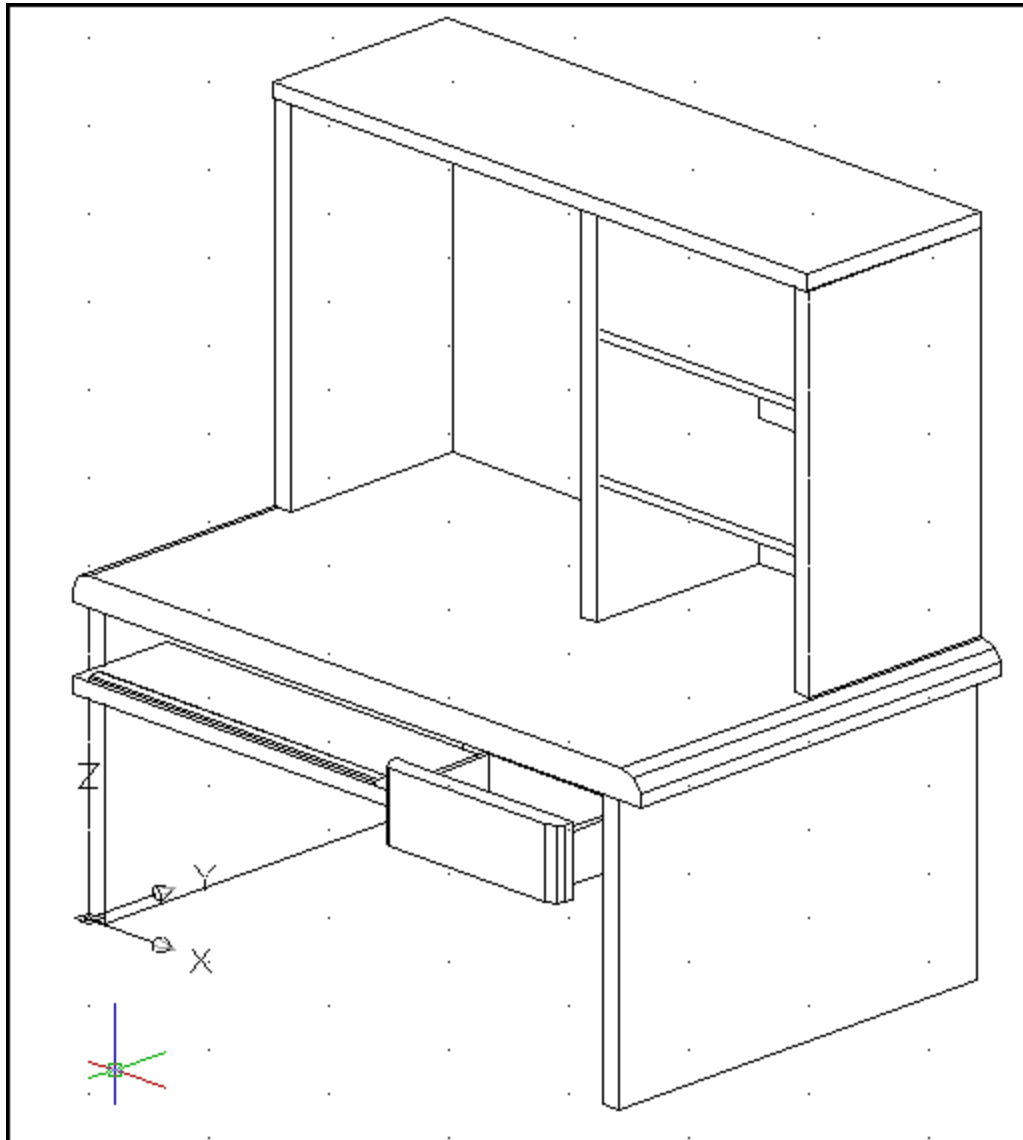

AutoCAD 3D Tutorial

3.2 Visual Styles

A visual style is a collection of settings that control the display of edges and shading in the viewport.

1. Open a drawing with 3D objects and display in a 3D view.
2. Choose View, Visual Styles and one of the following style options.

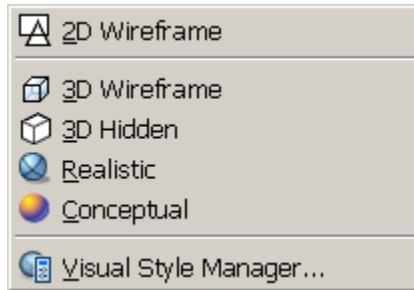

2D Wireframe

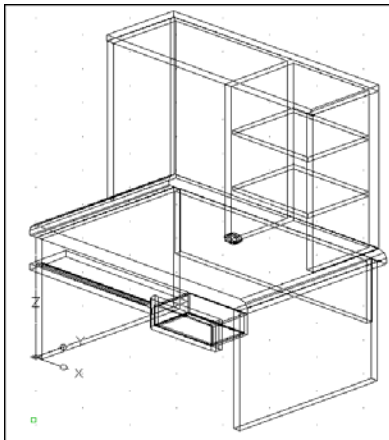

3D Wireframe

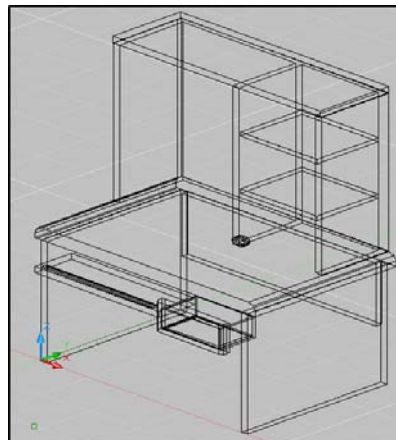

3D Hidden

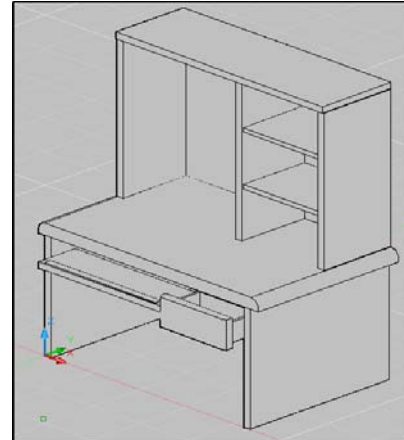

Realistic

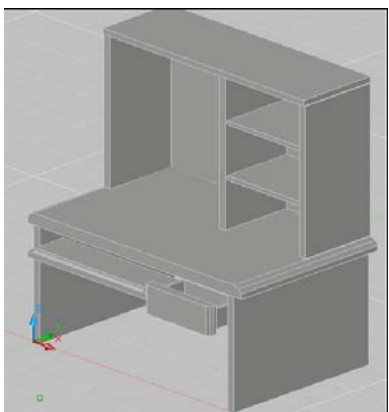

Conceptual

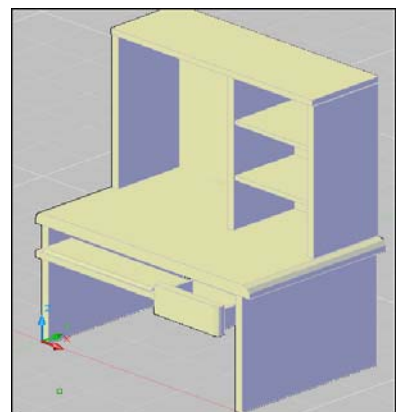

AutoCAD 3D Tutorial

3.3 Visual Style Manager

The Visual Styles Manager displays sample images of the visual styles available in the drawing. The selected visual style is indicated by a yellow border, and its settings are displayed in the panel below the sample images.

1. Choose **View, Visual Styles, Visual Styles Manager...**
or
2. Type VISUALSTYLES at the command prompt.
Command: **visualstyles**
3. Choose the desired option from one of those available in the drawing for 2D Wireframe, 3D Wireframe, 3D Hidden, Realistic, or Conceptual options.

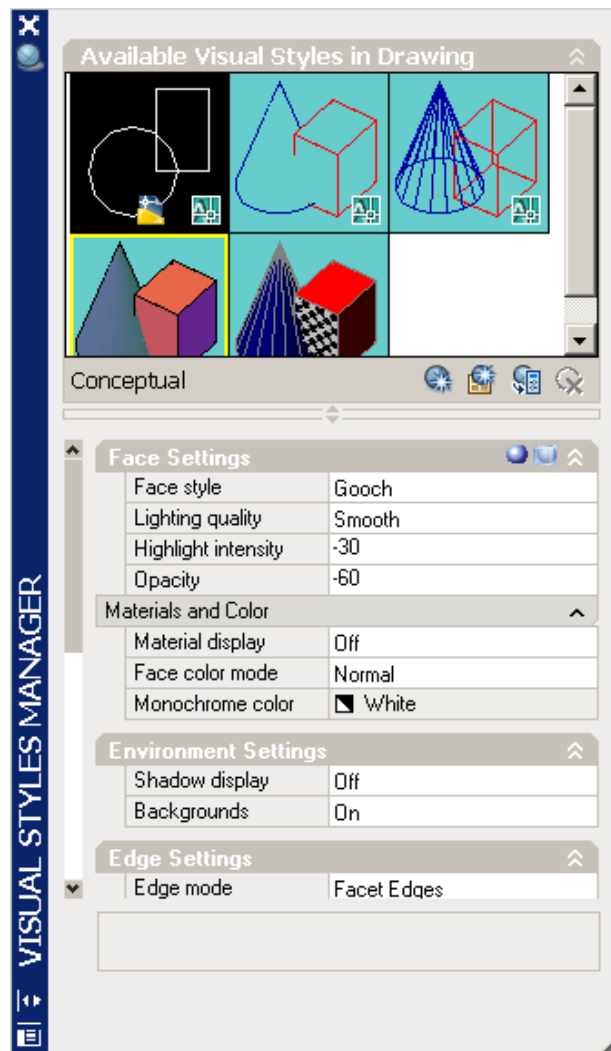

AutoCAD 3D Tutorial

3.4 Visual Styles Panel

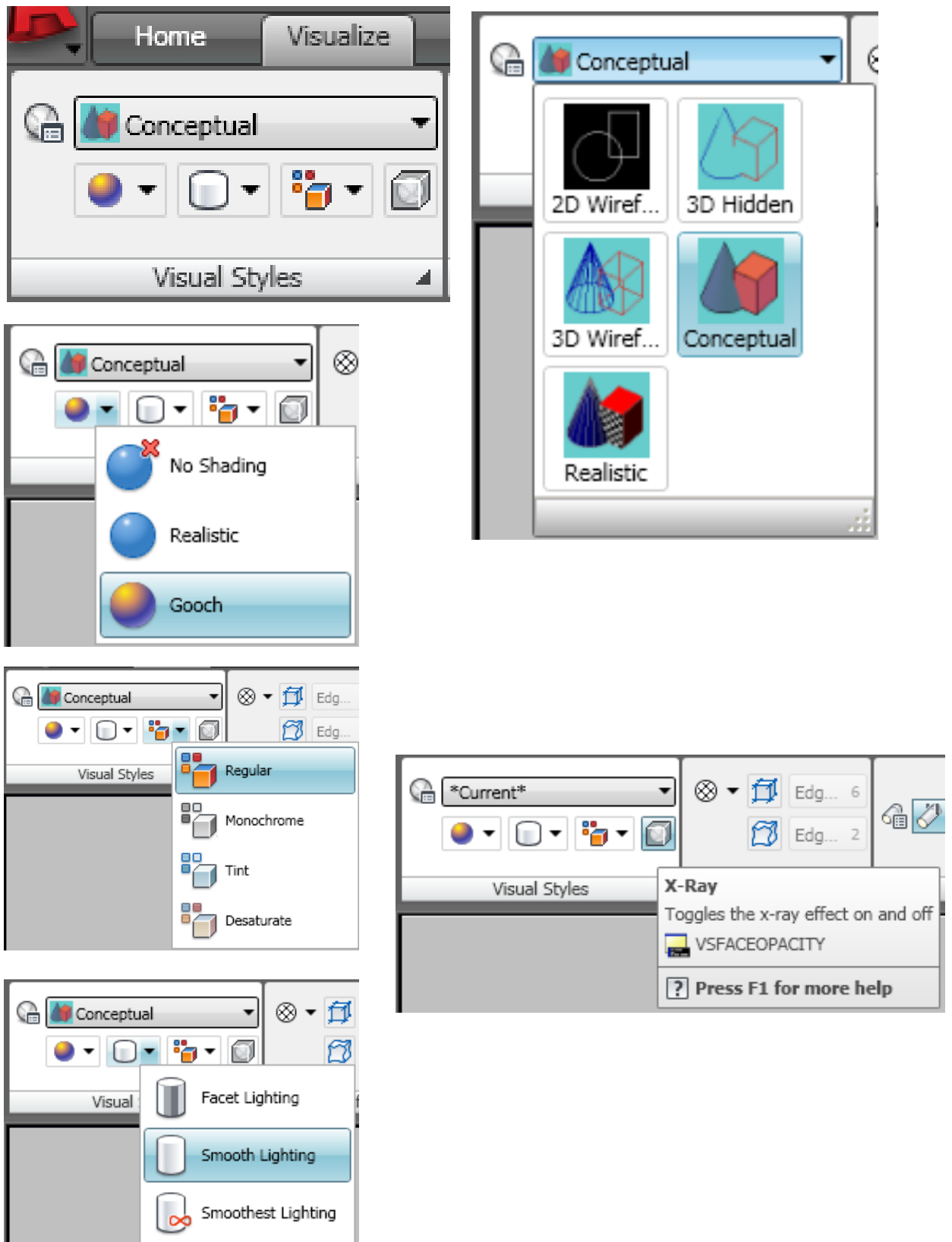

AutoCAD 3D Tutorial

3.5 Adaptive 3D Grid

When you choose a shaded or 3D wireframe visual style, the grid changes from a dotted grid to a rectangular grid. The new grid provides a better sense of a model's orientation in 3D. The rectangular grid supports perspective, can display major and minor grid lines, provides color options, and can automatically control the grid density when zooming in or out (adaptive grid.) You can change the grid settings using the drafting settings dialog box.

1. Choose **View, Visual Styles** and one of the following options:
3D Wireframe, 3D Hidden, Realistic, or Conceptual.

Change the adaptive grid settings

1. Choose **Tools, Drafting Settings**, and the **Snap and Grid TAB**.

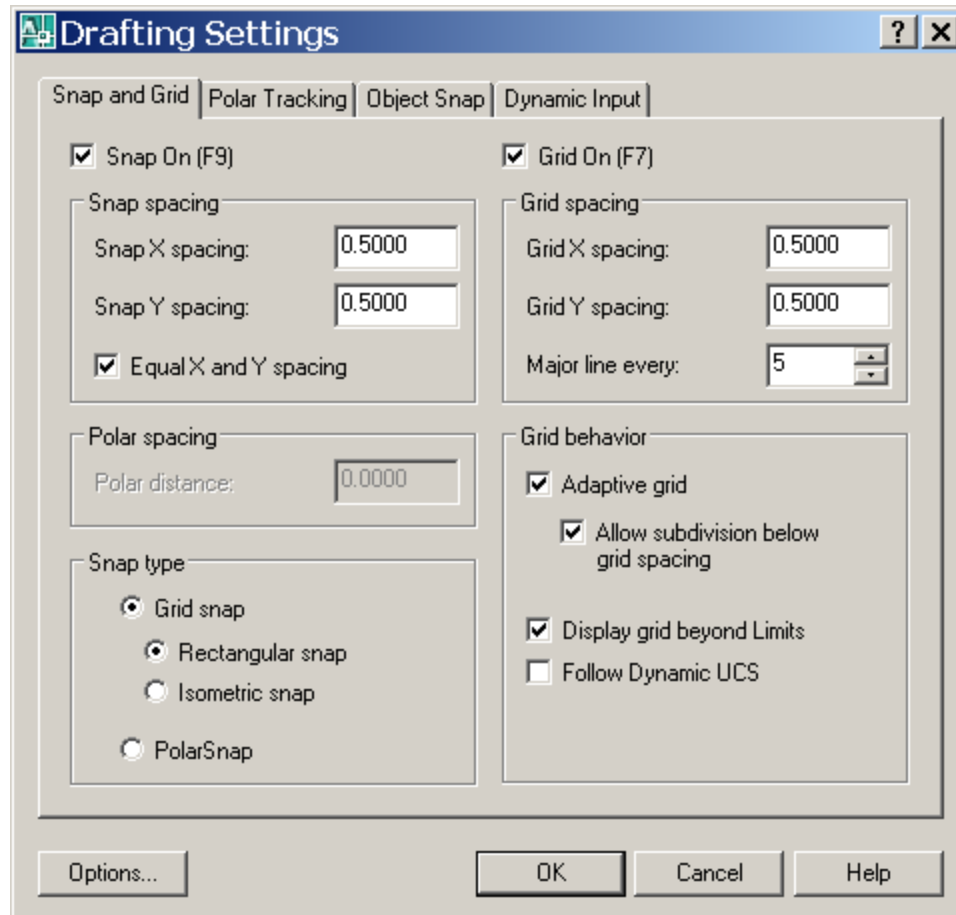

AutoCAD 3D – Chapter 4
Z Coordinates

AutoCAD 3D Tutorial

4.1 3D Coordinates

Entering 3D Cartesian coordinates (X,Y,Z) is similar to entering 2D coordinates (X,Y). In addition to specifying X and Y values, you specify a Z value.

1. Open a drawing with 3D objects and display in a 3D view.
2. Type 3DPoly at the command prompt.

Command: **3DPOLY**

Specify start point of polyline: **1,1,0**

Specify endpoint of line or [Undo]: **1,2,1**

Specify endpoint of line or [Undo]: **2,2,1**

Specify endpoint of line or [Close/Undo]: **2,1,0**

Specify endpoint of line or [Close/Undo]: **1,1,0**

The result will be the following lines that are drawn in 3D:

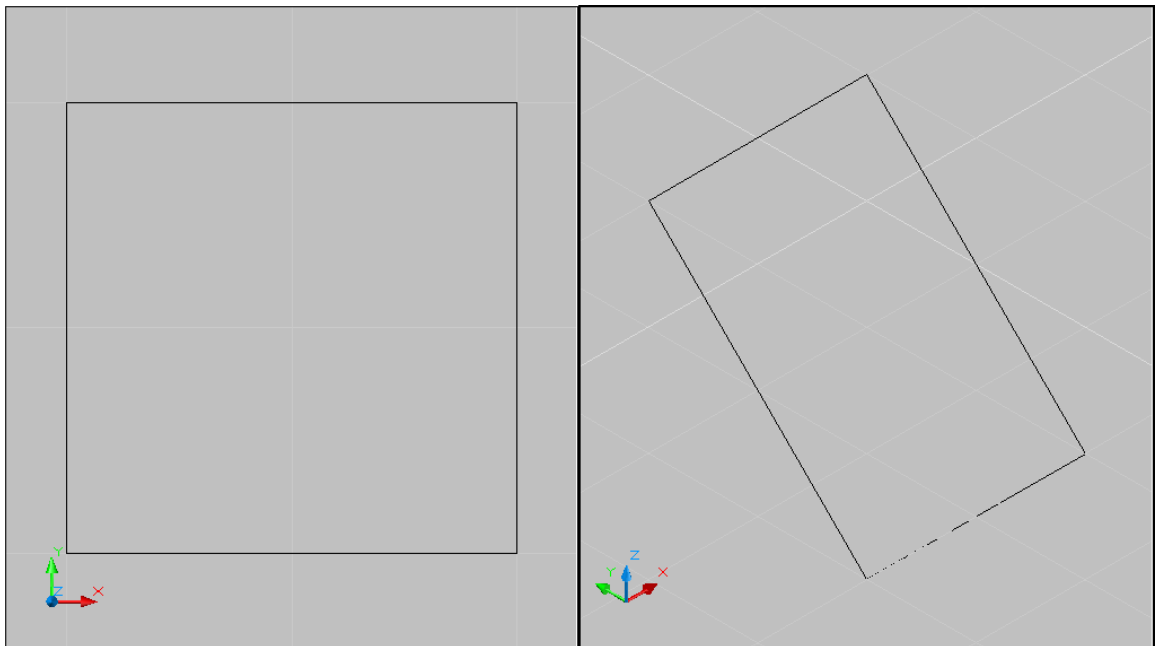

AutoCAD 3D Tutorial

4.2 Track in Z Direction

With AutoTrack (polar tracking and object snap tracking), you can track in the Z direction as well as in the XY plane. Similarly, when Ortho mode is turned on, you can lock the cursor to the Z direction.

1. Press **F11** or click **OSnap Tracking** on the status bar if it is not already on.
2. Press **F10** or click **Polar Tracking** on the status bar if it is not already on.
3. In a 3D view, issue the LINE command and draw a line in the Z direction using tracking.

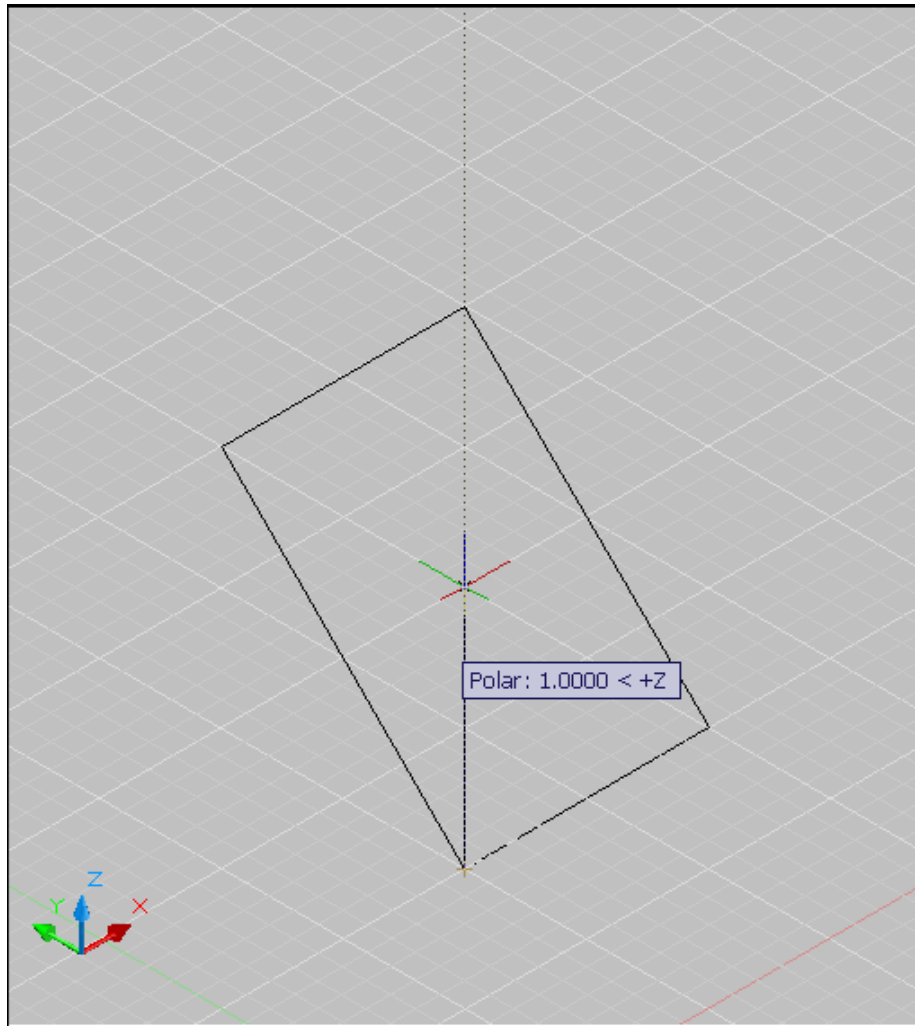

AutoCAD 3D Tutorial

4.3 Move in Z Direction

1. Open a drawing with 3D objects in it.
2. Type MOVE at the command prompt.

Command: **move**

Select objects: **pick object in 3D view**

Select objects: **press enter**

Specify base point or displacement:

Specify second point of displacement or

<use first point as displacement>: 0,0,1 or use polar tracking to move the object.

before move

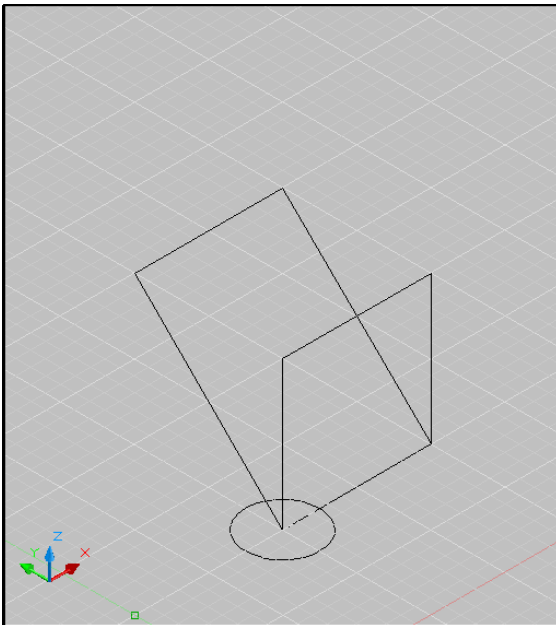

after move

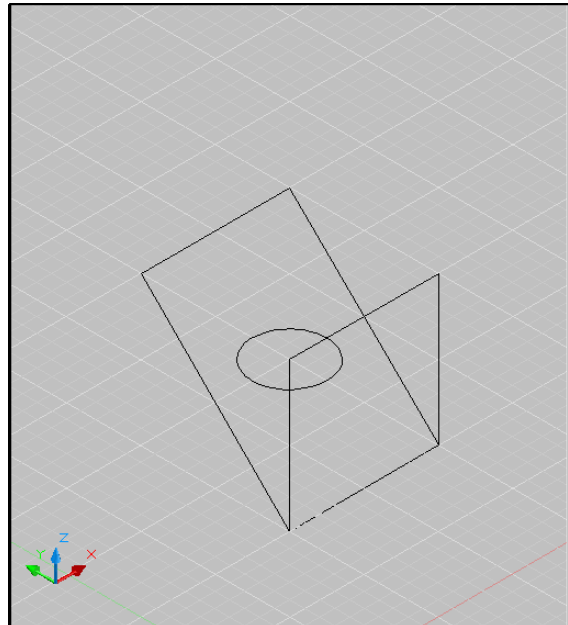

AutoCAD 3D Tutorial

4.4 3D Point Filters

Draws in 3D Z direction by filtering X and Y coordinates.

1. Open a drawing with 3D objects in it.

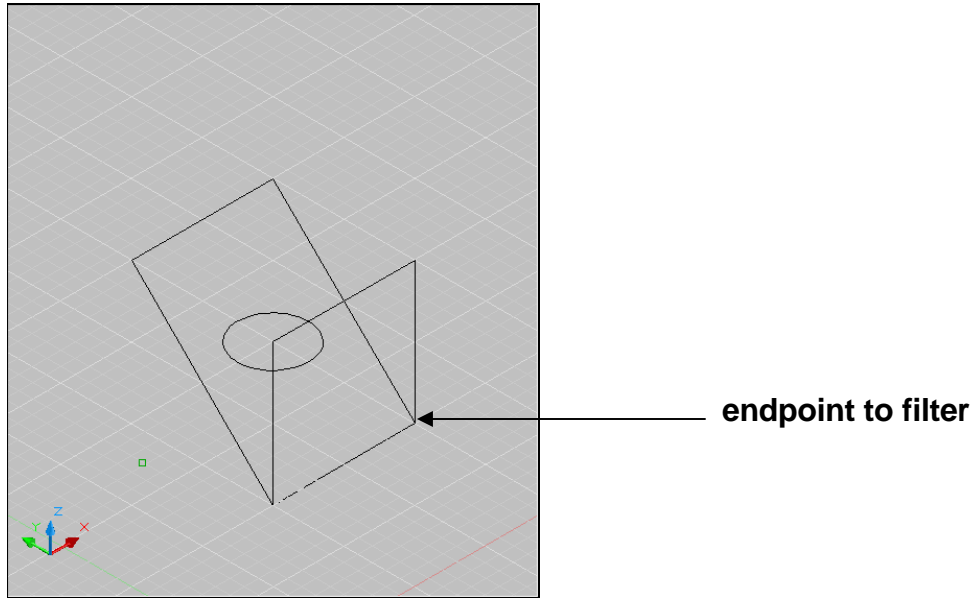

2. Use the CIRCLE command and place it using 3D point filters (.xy)
3. Command: **circle**
4. Specify center point for circle or [3P/2P/Ttr (tan tan radius)]: **.XY**
5. of **pick endpoint to filter**
6. (need Z): **1**
7. Specify radius of circle or [Diameter] <0.2500>: **press enter**

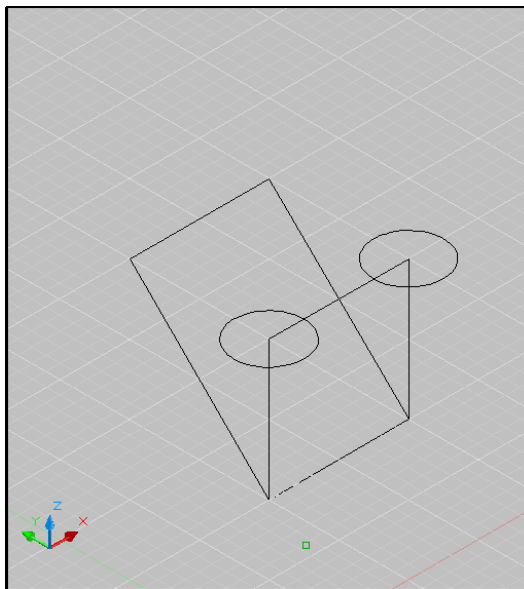

**AutoCAD 3D – Chapter 5
User Coordinate System**

AutoCAD 3D Tutorial

5.1 UCS Icon

The UCS icon represents the orientation of the user coordinate system (UCS) axes and the location of the current UCS origin. It also represents the current viewing direction relative to the XY plane. AutoCAD displays the UCS icon differently for 2D, 3D and Paper Space environments.

3D UCS icons

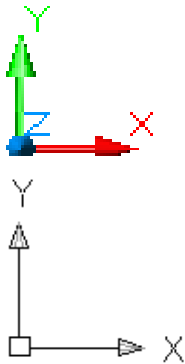

2D UCSIcon

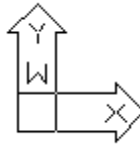

Pspace UCSICON

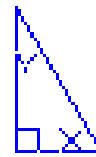

1. Choose **View, Display, UCS Icon**.

or

2. Type UCSICON at the command prompt.

Command: **ucsicon**

Enter an option [ON/OFF/All/Noorigin/ORigin/Properties] <ON>:

ON	Displays the UCS icon.
OFF	Turns off the display of the UCSICON.
All	Affects the display of the UCSICON in all viewports.
Noorigin	Always displays the UCS at the lower left corner.
Origin	Shows the UCS at the 0,0,0 origin of the current UCS.
Properties	Changes the display properties of the UCS icons(s).

AutoCAD 3D Tutorial

UCS Icon Properties

1. Choose **View, Display, UCS Icon, Properties.**

or

2. Type UCSICON at the command prompt.

Command: **ucsicon**

Enter an option [ON/OFF/All/Noorigin/ORigin/Properties] <ON>: **P**

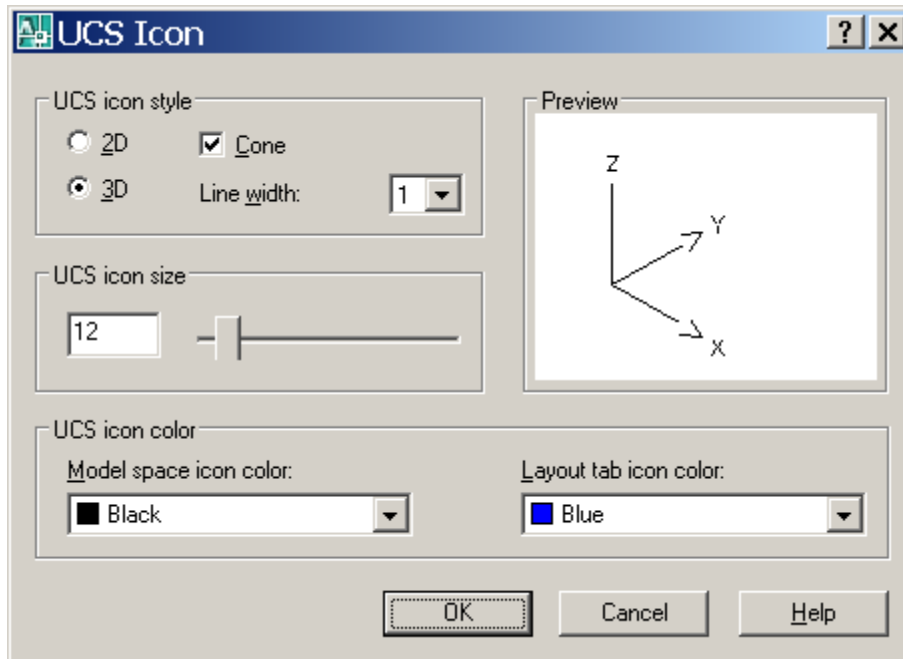

AutoCAD 3D Tutorial

5.2 UCS Overview

The user coordinate system provides an alternate movable coordinate system for coordinate entry, planes of operation, and viewing. Most AutoCAD geometric editing commands are dependent on the location and orientation of the UCS. There are a variety of ways to set the User Coordinate System using the UCS command.

1. Type UCS at the command prompt.

Command: **ucs**

Enter an option [New/Move/orthoGraphic/Prev/Restore/Save/Del/Apply/?/World] <World>:

New	Defines a new coordinate system by one of six methods: Origin, Z Axis, 3 Point, Object, Face, View X, Y, Z
Origin	Defines a new UCS by shifting the origin of the current UCS, leaving the direction of the X,Y, and Z axes unchanged.
ZAxis	Allows you to define a new origin.
3 Point	Specifies a UCS by its origin and a point on the positive X and Y axes.
Object	Lets you define a new UCS by pointing at an object.
Face	Aligns the UCS to the selected face of a solid object.
View	Establishes a new UCS whose XY plane is perpendicular to your viewing direction (e.g. parallel to your screen).
X/Y/Z	Rotates the ucs around a specified axis

UCS Toolbars

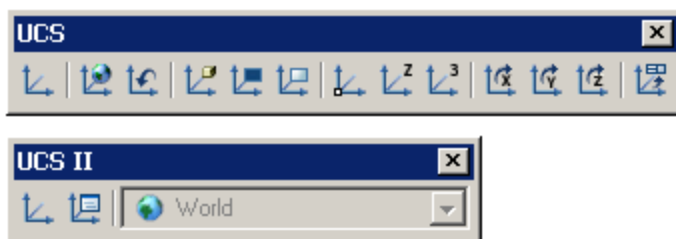

AutoCAD 3D Tutorial

5.3 3 Point UCS

The 3 Point option is one of the easiest ways to define a new UCS on a given 3D object.

1. Open a drawing with a simple 3D object (e.g. 3D box)
2. Type UCS at the command prompt.

Command: **ucs**

Enter an option [New/Move/orthoGraphic/Prev/Restore/Save/Del/Apply/?/World] <World>: **N**

Specify origin of new UCS or [ZAxis/3point/OBject/Face/View/X/Y/Z] <0,0,0>: **3**

Specify new origin point <0,0,0>: **pick origin**

Specify point on positive portion of X-axis <3.53,7.73,0.00>: **pick point for X direction**

Specify point on positive-Y portion of the UCS XY plane

<2.53,8.73,0.00>: **pick point for Y direction**

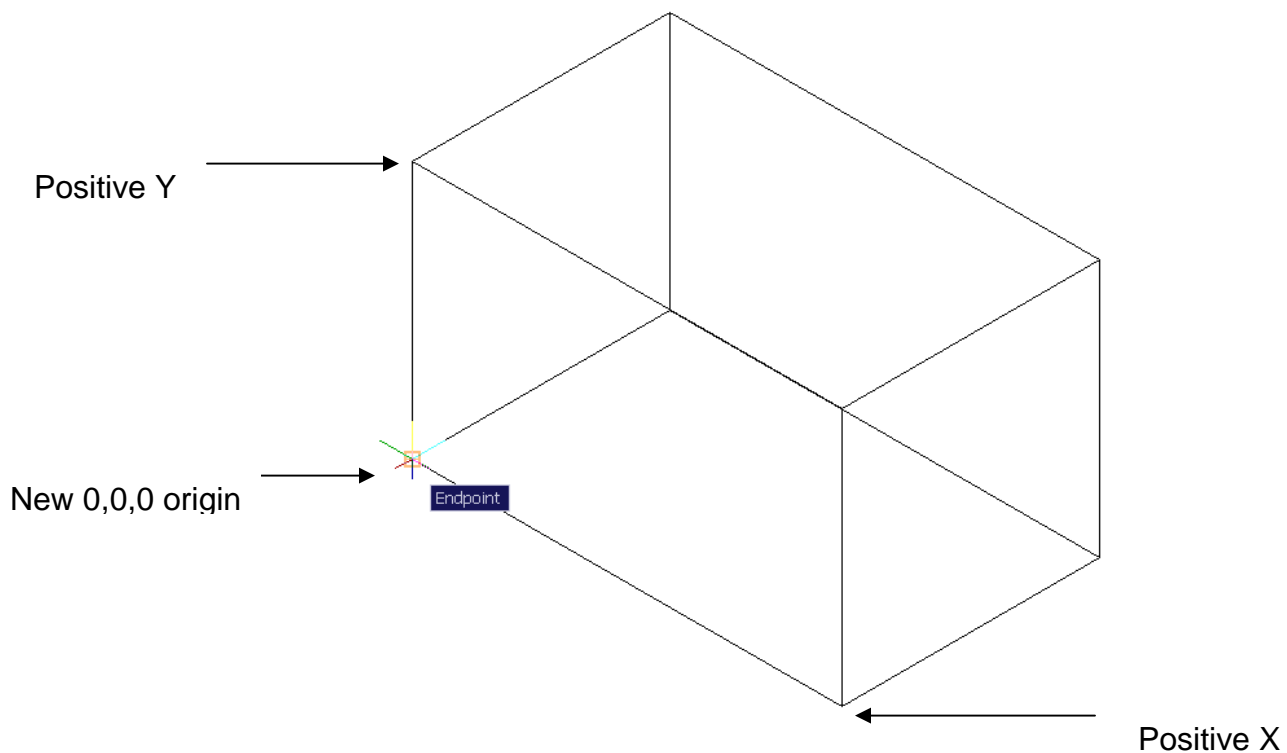

AutoCAD 3D Tutorial

New UCS

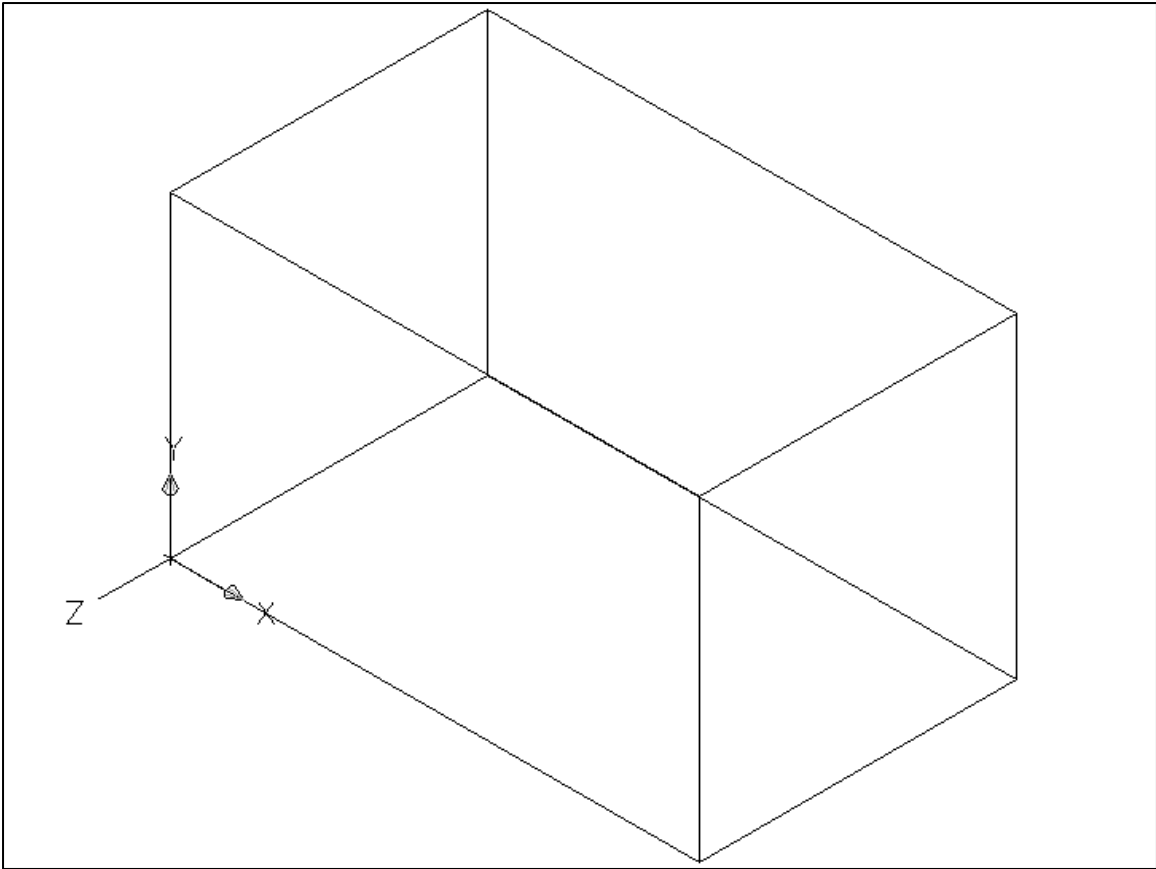

AutoCAD 3D Tutorial

5.4 Plan UCS

To work in the plan view of your new UCS, use the PLAN command with the current UCS option. New entities that you draw will be in relation to this current UCS.

1. Type PLAN at the command prompt.

Command: **plan**

Enter an option [Current ucs/Ucs/World] <Current>: **press enter**

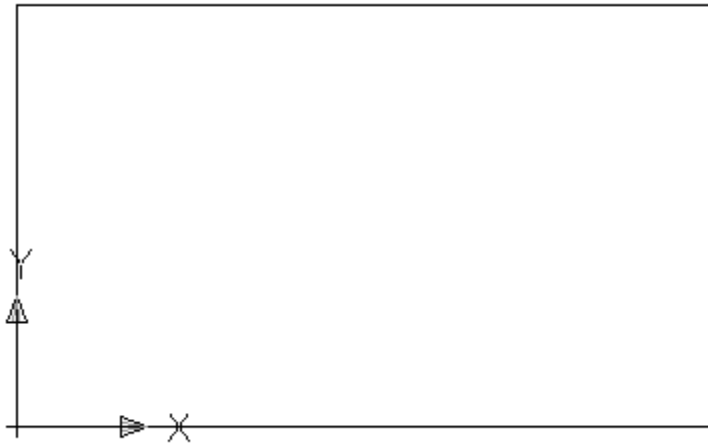

AutoCAD 3D Tutorial

5.5 World UCS

The World UCS is the only UCS guaranteed to be the same in all AutoCAD drawings and can be used to set the UCS back to its original state. This is the UCS you should use when creating Wblocks and inserting Wblocks.

1. Type UCS at the command prompt.

Command: **ucs**

Current ucs name: *NO NAME*

Enter an option [New/Move/orthoGraphic/Prev/Restore/
Save/Del/Apply/?/World] <World> **W**

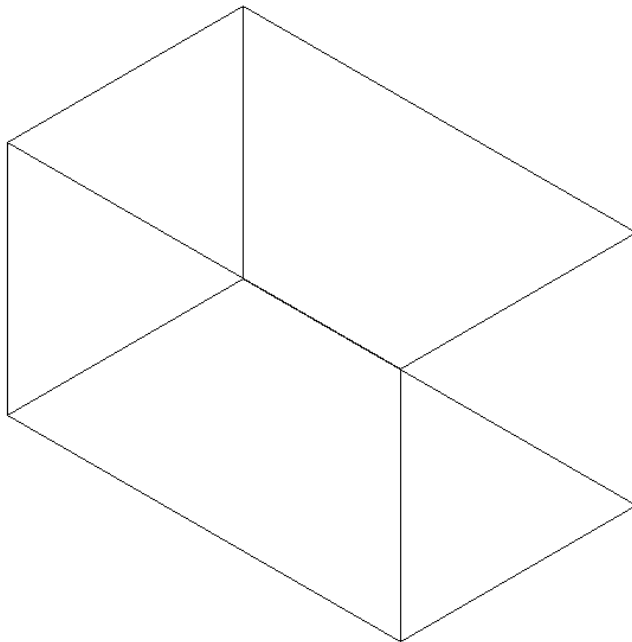
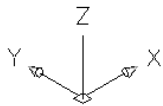

AutoCAD 3D Tutorial

5.6 View UCS

Establishes a new coordinate system whose XY plane is perpendicular to your viewing direction (i.e. parallel to your screen)

1. Type UCS at the command prompt.

Command: **ucs**

Current ucs name: *NO NAME*

Enter an option [New/Move/orthoGraphic/Prev/Restore/
Save/Del/Apply/?/World] <World>: **N**

Specify origin of new UCS or [ZAxis/3point/OBject/ Face/View/X/Y/Z]
<0,0,0>: vOrigin/ZAxis/3point/
OBject/View/X/Y/Z/Prev/Restore/Save/Del/?/<World>:**V**

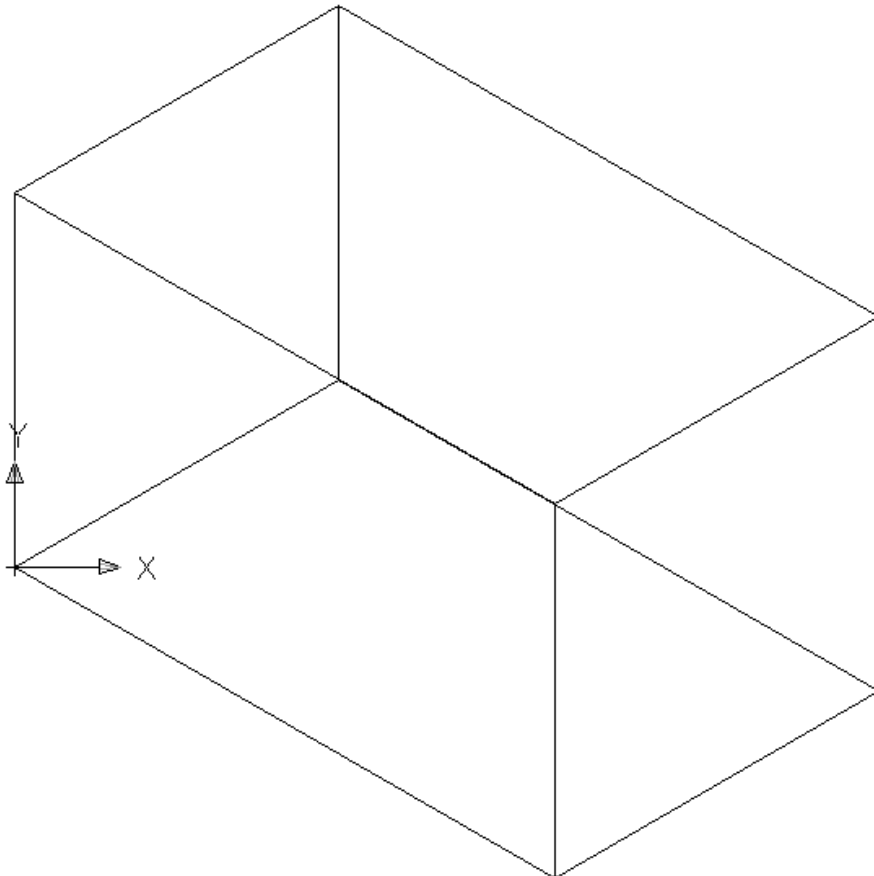

AutoCAD 3D Tutorial

5.7 Dynamic UCS

You can use the dynamic UCS to create objects on a planar face of a 3D solid without manually changing the UCS orientation.

During a command, the dynamic UCS temporarily aligns the XY plane of the UCS with a planar face of a 3D solid when you move the cursor over the face.

When the dynamic UCS is active, specified points, and drawing tools, such as polar tracking and the grid, are all relative to the temporary UCS established by the dynamic UCS. 1.

1. Click the DUCS icon  on the status bar or press **CTRL +D**.
2. Type any draw command.
Command: circle
3. Move the cursor to the face of the 3D object that you would like to draw on.

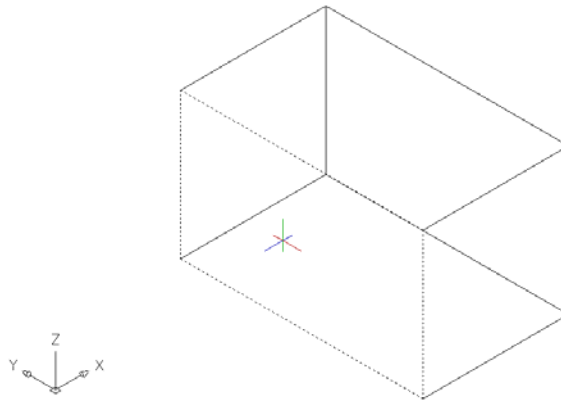

4. Click to begin drawing your new object.

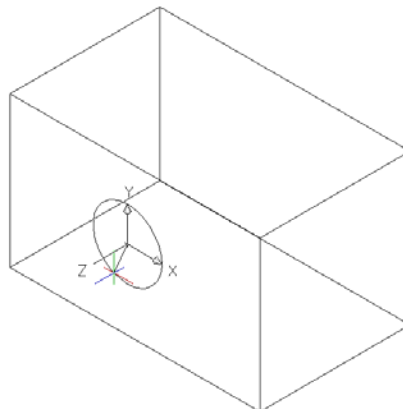

AutoCAD 3D Tutorial

5.8 Naming and Saving a UCS

User coordinate systems can sometimes be complicated and it is often useful to name and save them so you can quickly recall them.

1. Type UCS at the command prompt.

Command: UCS

Specify origin of UCS or

[Face/NAmed/OBject/Previous/View/World/X/Y/Z/ZAxis]

<World>: **NA**

Enter an option [Restore/Save/Delete/?]: **S**

Enter name to save current UCS or [?]: **LeftSide**

AutoCAD 3D Tutorial

5.9 Restoring a UCS

A named and saved UCS can be restored at any time.

1. Type UCS at the command prompt.

Command: **UCS**

Specify origin of UCS or

[Face/NAmed/OBject/Previous/View/World/X/Y/Z/ZAxis]

<World>: **NA**

Enter an option [Restore/Save/Delete/?]: **R**

Enter name to save current UCS or [?]: **LeftSide**

AutoCAD 3D Tutorial

5.10 UCS Dialog Box

Displays and modifies defined and unnamed user coordinate systems, restores named and orthographic UCSs, and specifies UCS icon and UCS settings for viewports via a dialog box.

1. Chose Tools, Named UCS.
or
2. Type UCSMAN at the command prompt.

Command: **ucsman**

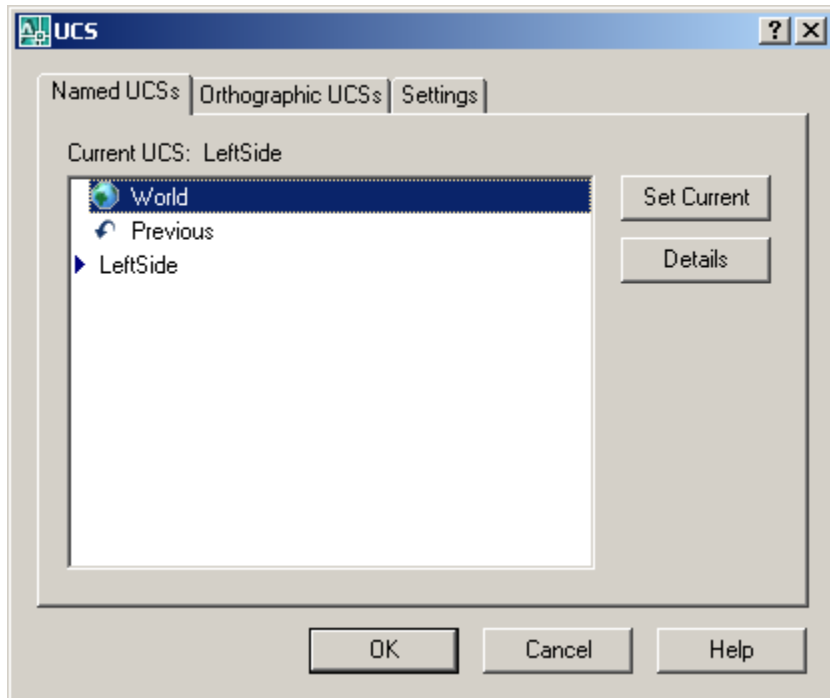

AutoCAD 3D Tutorial

5.10 Viewcube

The ViewCube provides visual feedback about the current orientation of a model. The ViewCube can help you adjust the viewpoint of a model. The orientation shown by the ViewCube is based on the North direction of the WCS for the model. The ViewCube also shows the current UCS and allows you to restore a named UCS.

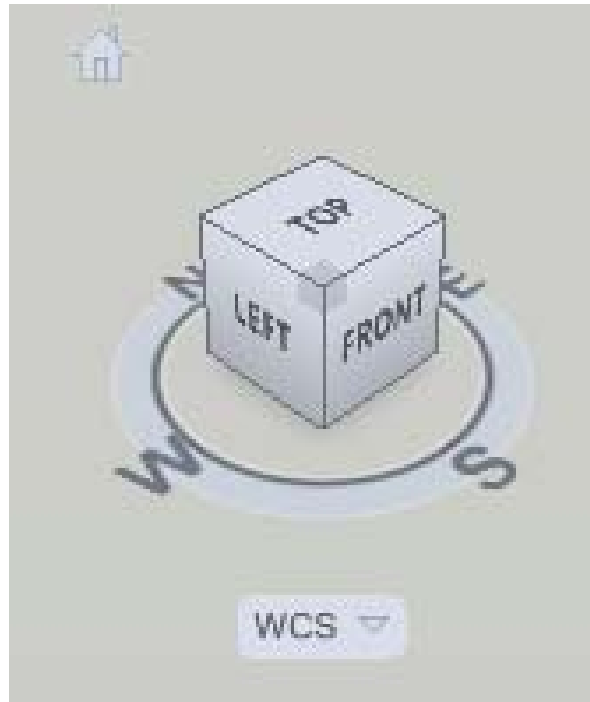

AutoCAD 3D – Chapter 6
3D Orbit

AutoCAD 3D Tutorial

6.1 Constrained 3D Orbit

3DORBIT activates a 3D Orbit view in the current viewport. You can view your entire drawing or select one or more objects before starting the command.

When 3DORBIT is active, the target of the view stays stationary and the camera location, or point of view, moves around the target. However, from the user's point of view, it appears as if the 3D model is turning as the mouse cursor is dragged. In this way, you can specify any view of the model.

1. Open a drawing with 3D objects.
2. Choose **View, Orbit, Constrained Orbit**.
or
3. Type 3D Orbit at the command prompt.
Command: **3DOrbit**
4. Click and drag to move your object in 3D.

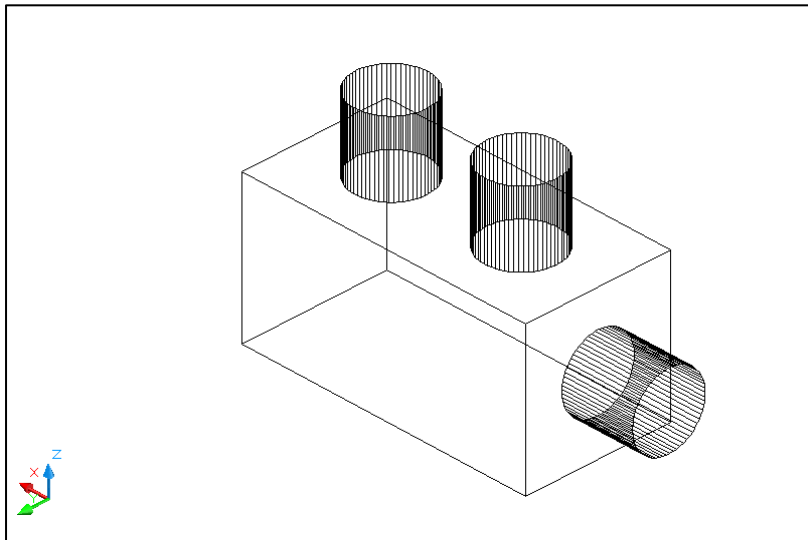

AutoCAD 3D Tutorial

6.2 Zoom and Pan in 3D Orbit

Zoom

1. Click with the **right mouse** button while in the 3D Orbit command.
2. Choose **Zoom Window** from the pop-up menu.

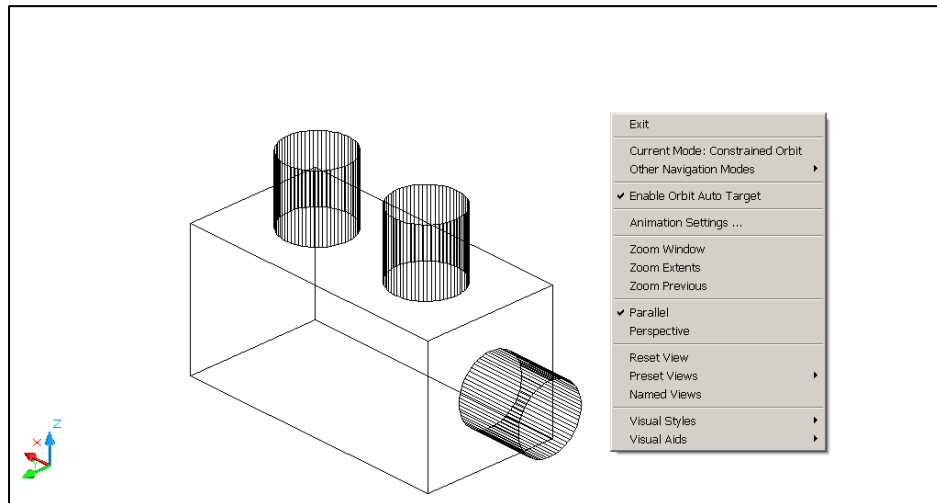

3. Zoom to a new area of the 3D drawing.
4. Click with the **right mouse** button while in the 3D Orbit command.
5. Choose **Zoom Previous** or **Zoom Extents** from the pop-up menu.

Pan

1. Click with the **right mouse** button while in the 3D Orbit command.
2. Choose **Other Navigation Modes** from the pop-up menu.
3. Choose **Pan**.
4. Pan to a new area of the drawing.
5. Click with the **right mouse** button while in the 3D Orbit command.
6. Choose **Other Navigation Modes** from the pop-up menu.
7. Choose **Constrained Orbit** to set the mode back to orbit.

AutoCAD 3D Tutorial

6.3 Projection Mode

1. Click with the **right mouse** button while in the 3D Orbit command.
2. Choose **Perspective**.

Perspective view displays objects in perspective so that all parallel lines converge at one point. Objects appear to recede into the distance, and parts of the objects appear larger and closer to you. The shapes are some what distorted when the object is very close. This view correlates more closely to what your eye sees.

Parallel view displays objects so that two parallel lines in a drawing never con verge at a single point. The shapes in your drawing always remain the same and do not appear distorted when they are closer.

Perspective View

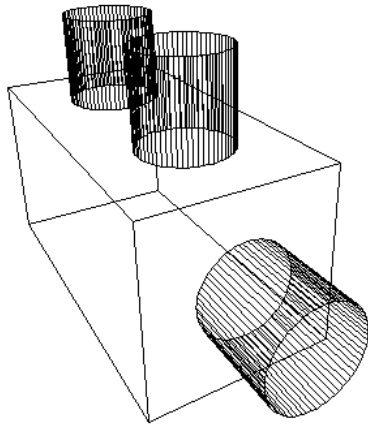

Parallel View

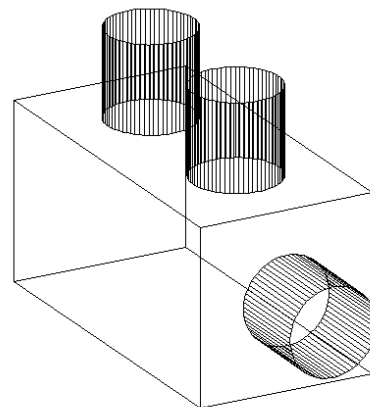

AutoCAD 3D Tutorial

6.4 Visual Styles

Displays your objects in one of the following selected styles:

1. Click with the **right mouse** button while in the 3D Orbit command.
2. Choose **Visual Styles** from the pop-up menu.
3. Choose **3D Hidden**, **3D Wireframe**, **Conceptual** or **Realistic**.

3D Hidden

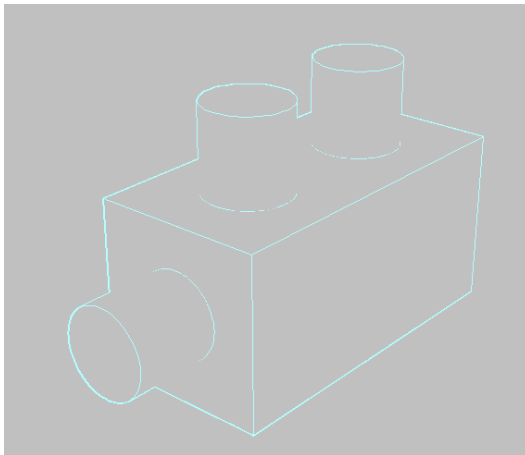

3D Wireframe

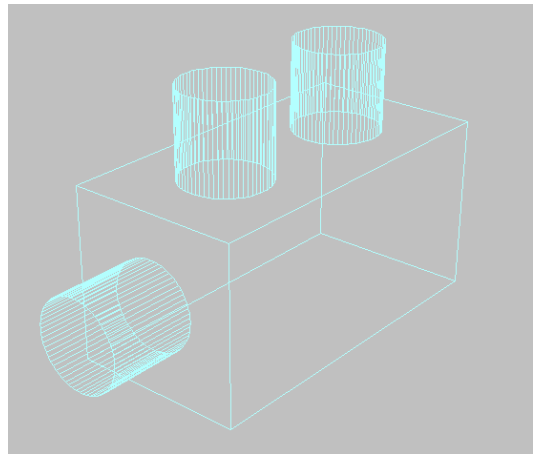

Conceptual

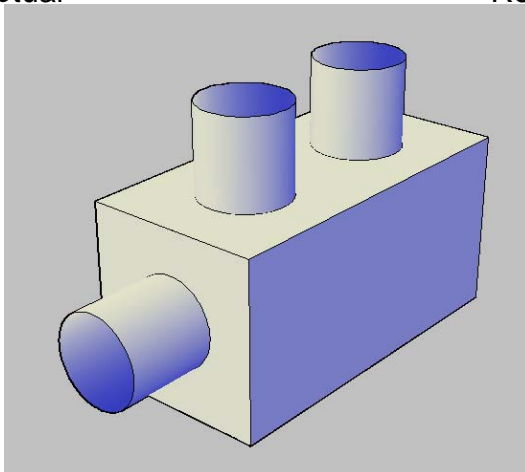

Realistic

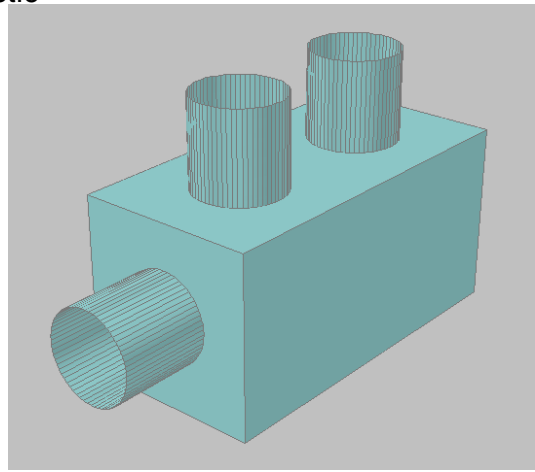

AutoCAD 3D Tutorial

6.5 Visual Aids

1. Click with the **right mouse** button while in the 3D Orbit command.
2. Choose **Visual Aids** from the pop-up menu.
3. Choose **Compass, Grid, or UCS Icon**.

Compass

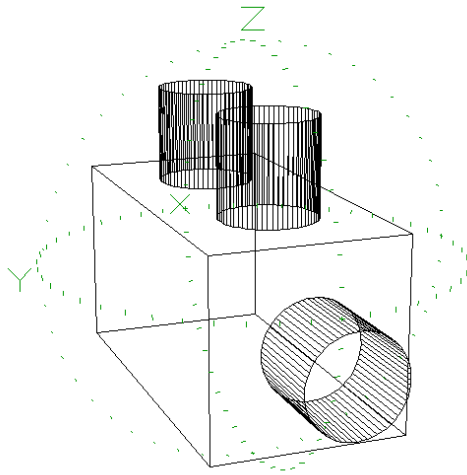

Grid

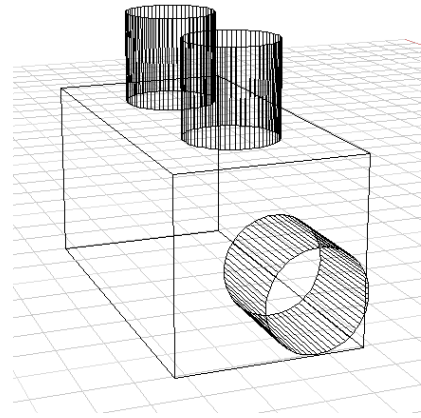

UCS Icon

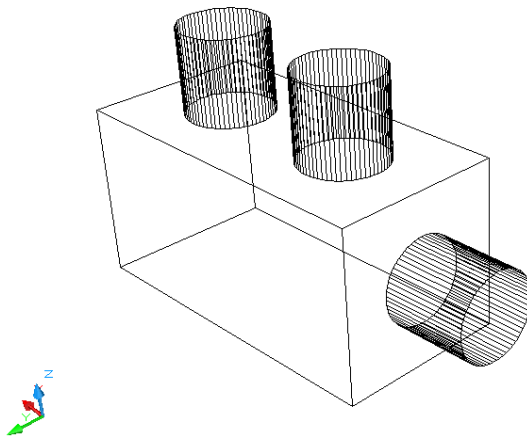

AutoCAD 3D Tutorial

6.6 Preset Views

Sets the 3D view while in the orbit command

1. Click with the **right mouse** button while in the 3D Orbit command.
2. Choose **Preset Views** from the pop-up menu.
3. Choose one of the following standard 3D views.

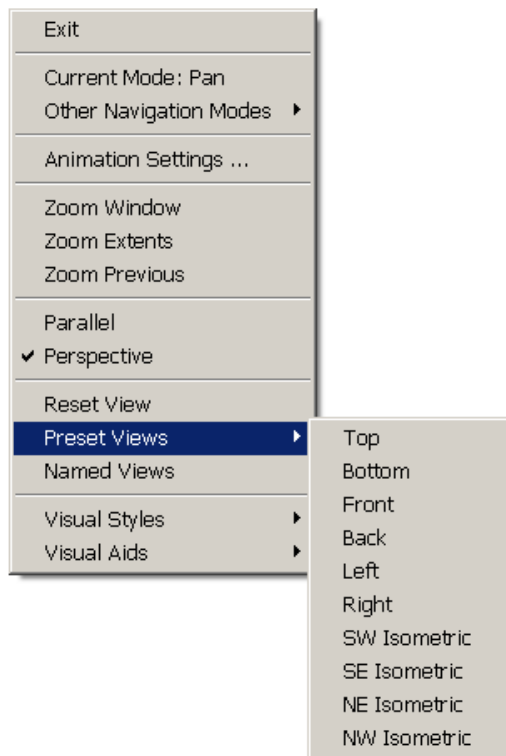

AutoCAD 3D Tutorial

6.7 Free Orbit

1. Choose **View, Orbit, Free Orbit**.
The 3D Orbit Arcball appears.
2. Click on one of the 3D Orbit arcball locations to move the display of your object(s).

Outside the Arcball - Moves View about an axis that extends through the center (acts like twist)

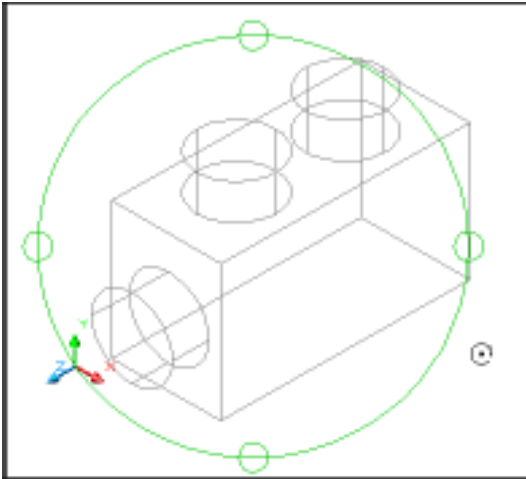

Inside one of the small circles to the left/right - Rotates around the "Y" axis through the center.

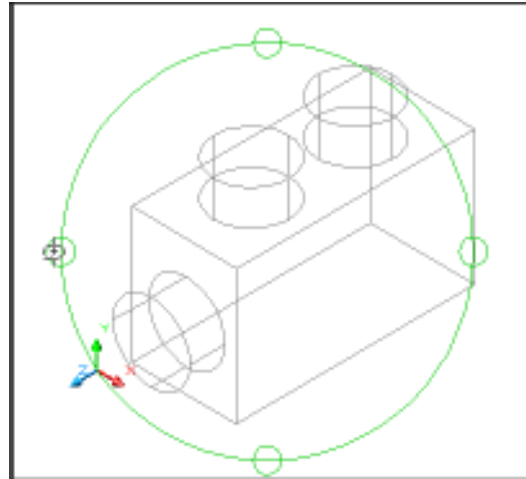

Inside the Arcball - Allows movement in any direction

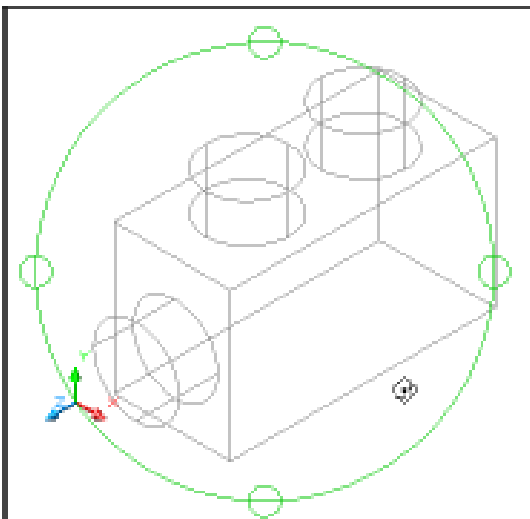

Inside one of the small circles to the top/bottom - Rotates around the "X" axis through the center.

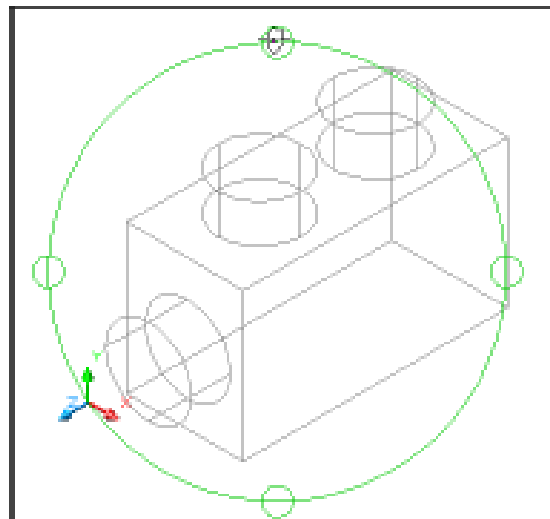

AutoCAD 3D Tutorial

6.8 Continuous Orbit

1. Choose **View, Orbit, Continuous Orbit**.
2. Click and drag to define the direction and speed of a continuous orbit for your object(s).
3. Press **ESC** on the keyboard to stop the orbit.

AutoCAD 3D Tutorial

6.9 Other Navigational Modes

1. Click with the **right mouse** button while in the 3D Orbit command.
2. Choose **Other Navigational Modes** from the pop-up menu.
3. Choose one of the following modes.

Adjust Distance (4) Simulates moving the camera closer to the object or farther away.

Swivel (5) Changes the cursor to an arched arrow and simulates the effect of swiveling the camera. See 3DSWIVEL.

Walk (6) Changes the cursor to a plus sign and enables you to "walk through" a model at a fixed height above the XY plane, by dynamically controlling the location and target of the camera. See 3DWALK.

Fly (7) Changes the cursor to a plus sign and enables you to "fly through" a model without being restricted to a fixed height above the XY plane. See 3DFLY.

Zoom (8) Changes the cursor to a magnifying glass with plus (+) and minus (-) sign and simulates moving the camera closer to an object or farther away. Works like the Adjust Distance option. See 3DZOOM.

AutoCAD 3D – Chapter 7
3D Navigation

AutoCAD 3D Tutorial

7.1 Creating a Camera

Sets a camera and target location to create and save a 3D perspective view of objects.

1. Open a drawing with 3D objects.
2. Choose View, Create Camera.

or

3. Type CAMERA at the command prompt.

Command: **camera**

Current camera settings: Height=5.0000 Lens Length=50.0000 mm

Specify camera location: **.xy**

of (need Z): **7**

Specify target location: **endp**

Enter an option

[?/Name/LOcation/Height/Target/LEns/Clipping/View/eXit]<eXit>: **X**

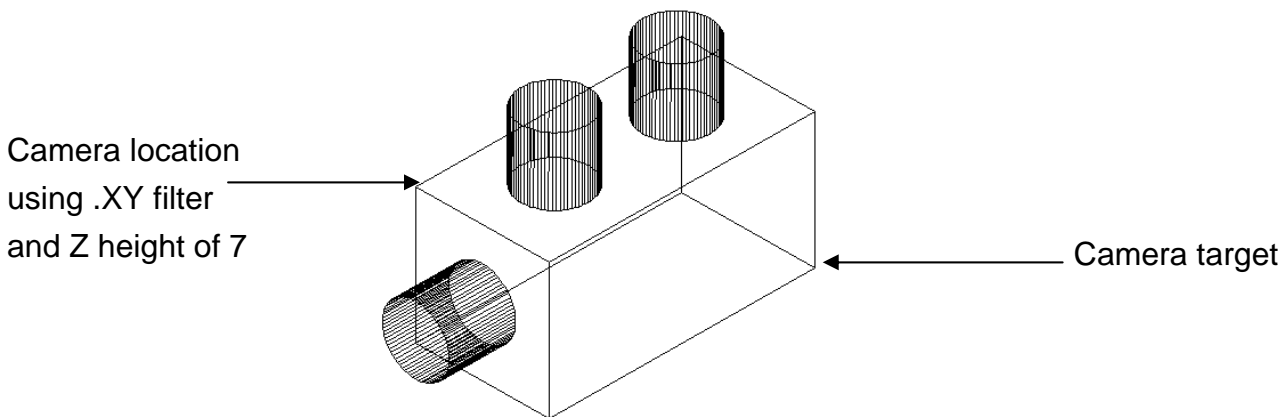

AutoCAD 3D Tutorial

7.2 Viewing a Camera

Once a camera is created, it becomes a named view in the drawing and can be viewed using the Named View Manager. You can also view the camera using the view option when creating the camera.

1. Choose **View, 3D Views, Southwest Isometric** to be sure you are not in an existing camera view.
2. Choose View, Named Views.
3. Click the plus (+) sign beside Model Views.
4. Click Camera1, Set Current, Apply, and OK.

View from Camera

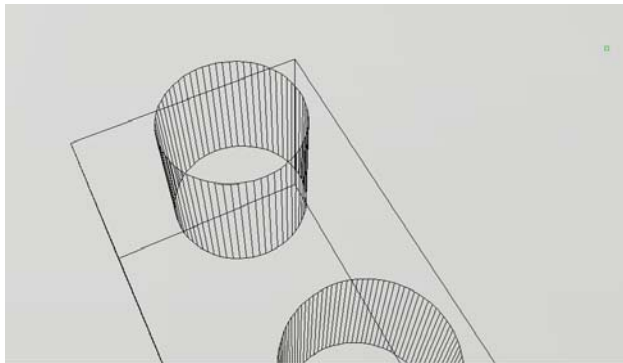

AutoCAD 3D Tutorial

7.3 Camera Preview

Camera preview is a quick and easy way to see the properties of a camera before viewing from the camera.

1. Choose **View, 3D Views, Southwest Isometric** to be sure you are not in an existing camera view.
2. Zoom out until you see the camera in your 3D view.
3. Click once on a camera in your view.

The Camera Preview dialog box will show the view from the chosen camera. You can change the Visual style of this preview to 3DHidden, 3DWireframe, Conceptual, or Realistic.

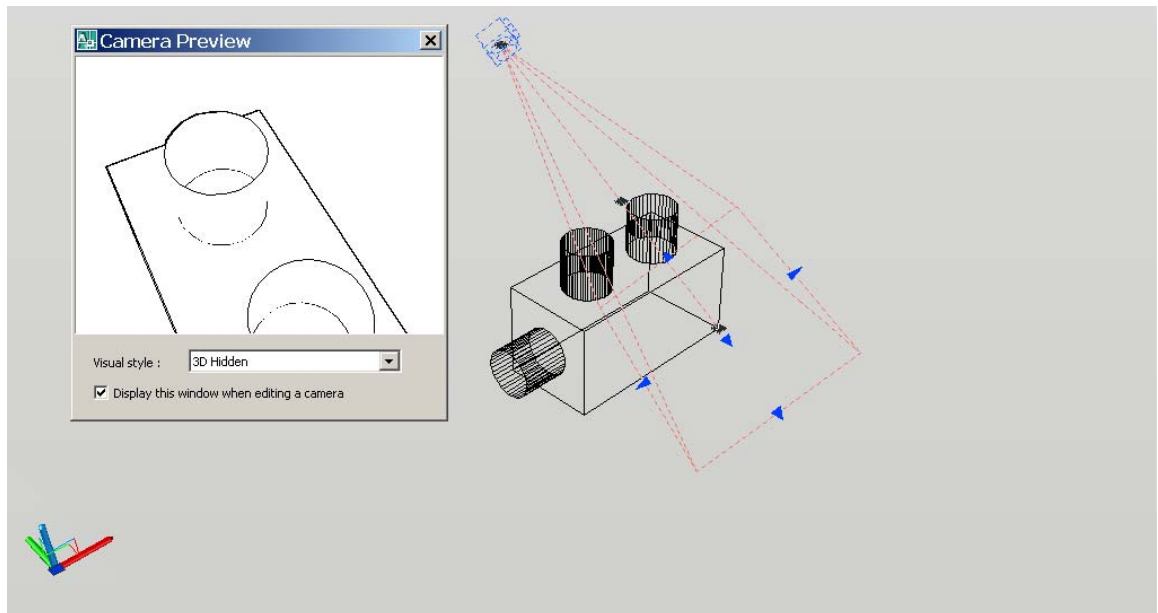

AutoCAD 3D Tutorial

7.4 Camera Properties

1. In a 3D isometric view, double click a camera.

The screenshot shows the Properties palette for a camera object. The palette is titled 'Camera' and contains two expandable sections: 'Camera' and 'Clipping'. The 'Camera' section lists various properties and their values, while the 'Clipping' section lists clipping plane settings.

Camera	
Name	Camera1
Camera X	6.9512
Camera Y	11.1174
Camera Z	7.0000
Target X	10.9512
Target Y	9.1174
Target Z	0.0000
Lens length (mm)	50.0000
Field of view	40
Roll angle	0
Plot	No

Clipping	
Front plane	0.0000
Back Plane	0.0000
Clipping	Off

AutoCAD 3D Tutorial

7.5 Displaying and Plotting a Camera

Displaying a Camera

1. Choose **View, Display, Cameras**.

Plotting a Camera

1. If cameras are not already displayed in the drawing, click **View, Display, Cameras**.
2. Double-click a camera.
3. In the Properties palette, Camera section, Plot option, click **Yes** or **No**.

7.6 Adjusting Camera Distances and Swiveling a Camera

Adjust Camera Distance

1. Choose View, Named Views.
2. Click the plus (+) sign beside Model Views.
3. Click Camera1, Set Current, Apply, and OK.
4. Choose View, Camera, Adjust Distance.
5. Click and drag to zoom in or out about the camera,

Swivel a Camera

1. Choose View, Camera, Swivel.
2. Click and drag to swivel the camera,

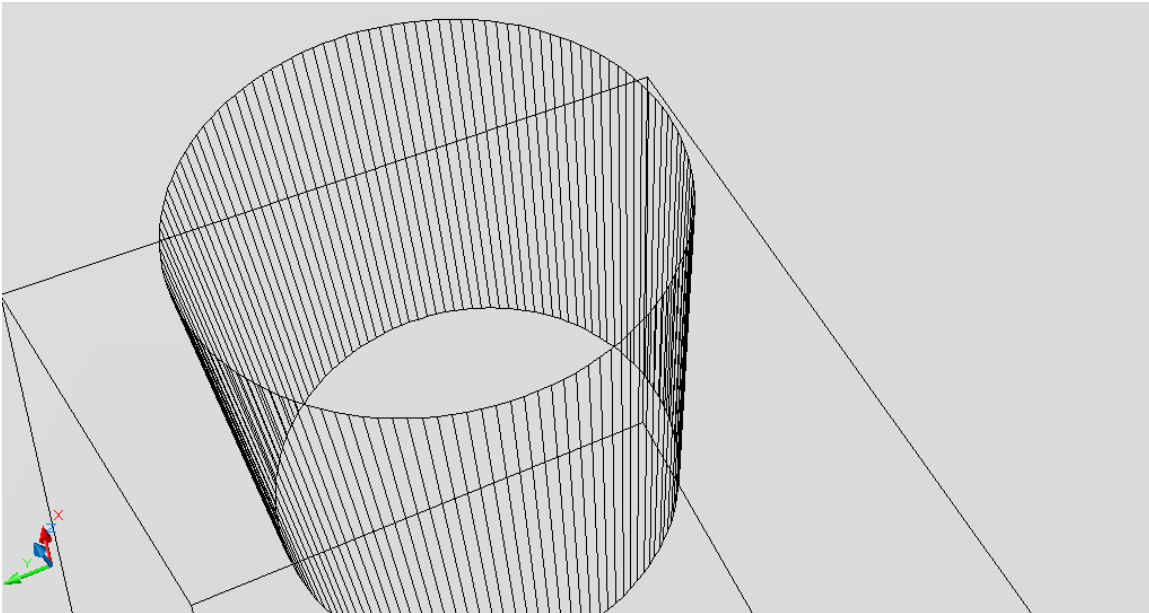

AutoCAD 3D Tutorial

7.7 DView Command

Defines parallel projection or perspective views by using a camera and target.

1. Type DVIEW at the command prompt.
Command: **dview**
Select objects or <use DVIEWBLOCK>: **pick objects**
Enter option
[CAmera/TARget/Distance/POints/PAn/Zoom/TWist/CLip/Hide/Off/Undo]: **PO**
Specify target point <3.2567, 4.0405, 7.2994>: **pick target**
Specify camera point <-4.0520, -3.2436, 14.3538>: **.XY**
of (need Z): **7**
Enter option
[CAmera/TARget/Distance/POints/PAn/Zoom/TWist/CLip/Hide/Off/Undo]: **D**
Specify new camera-target distance <8.3066>: **click and drag new zoom**
Enter option
[CAmera/TARget/Distance/POints/PAn/Zoom/TWist/CLip/Hide/Off/Undo]:
Regenerating model.

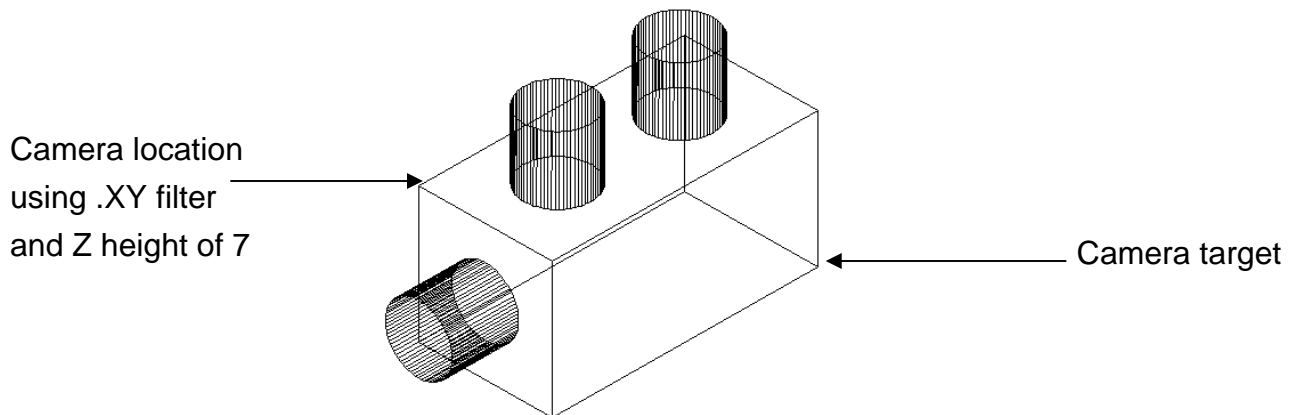

AutoCAD 3D Tutorial

New DView

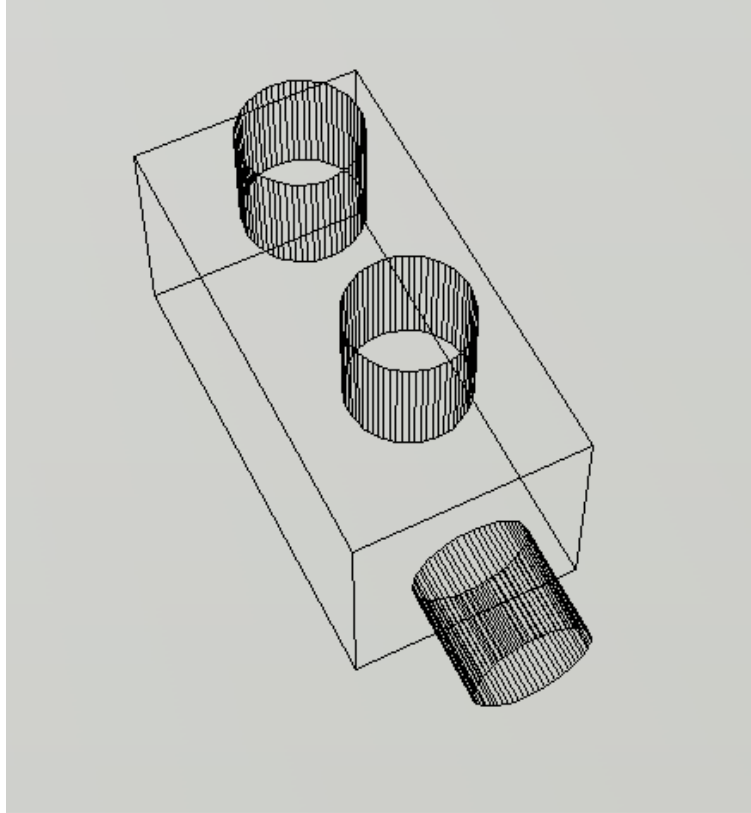

AutoCAD 3D Tutorial

7.8 Walk and Fly

You can simulate walking and flying through a 3D drawing.

When you walk through a model, you travel along the XY plane. When you fly through a model, you are not constrained by the XY plane, so you appear to “fly” over an area in a model.

The following mappings are available for walking:

Up arrow / W key	Move forward
Down arrow / S key	Move backward
Left arrow / A key	Move left
Right arrow / D key	Move right
Drag mouse	Look around & turn
F key Toggle	Fly mode

1. Open a drawing with 3D objects and display in a 3D view.
2. Create a camera anywhere in the drawing and set the view to that camera.
3. Choose **View, Walk and Fly, and Walk.**
or
4. Type 3DWalk or 3DFky at the command prompt.
Command: **3Dwalk**
5. The following walk and fly navigation mapping settings appear. Briefly look at the navigation keys, then choose close.

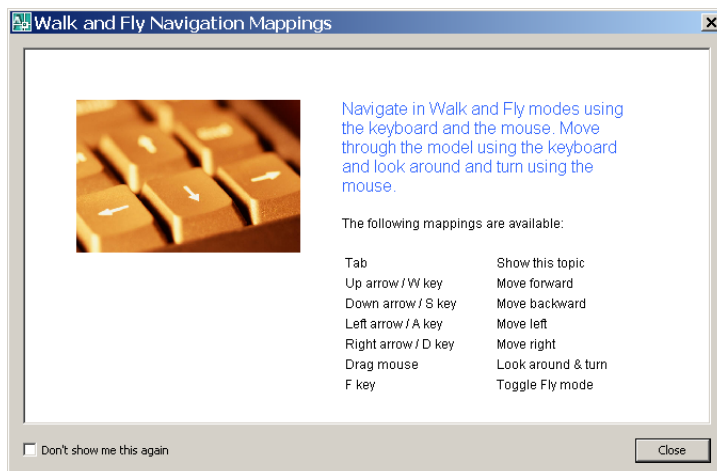

AutoCAD 3D Tutorial

The following Position Locator dialog box will appear that you can use to navigate your drawing.

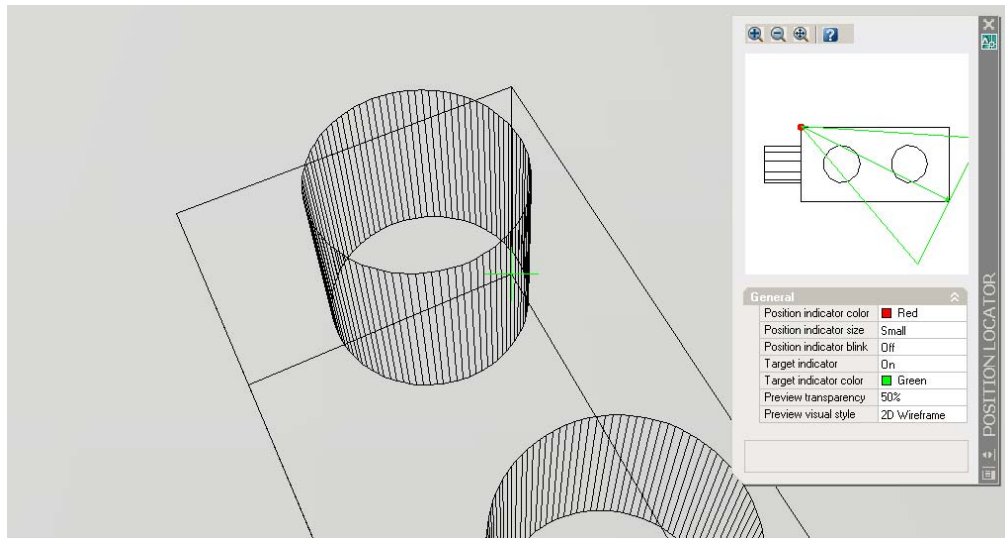

Press the Up, Down, Left, and Right keys on the keyboard to see how the camera location moves in the drawing and Position Locator dialog box.

Move the camera and target in the Position Locator dialog box.

Click and drag your mouse to “fly” through the drawing.

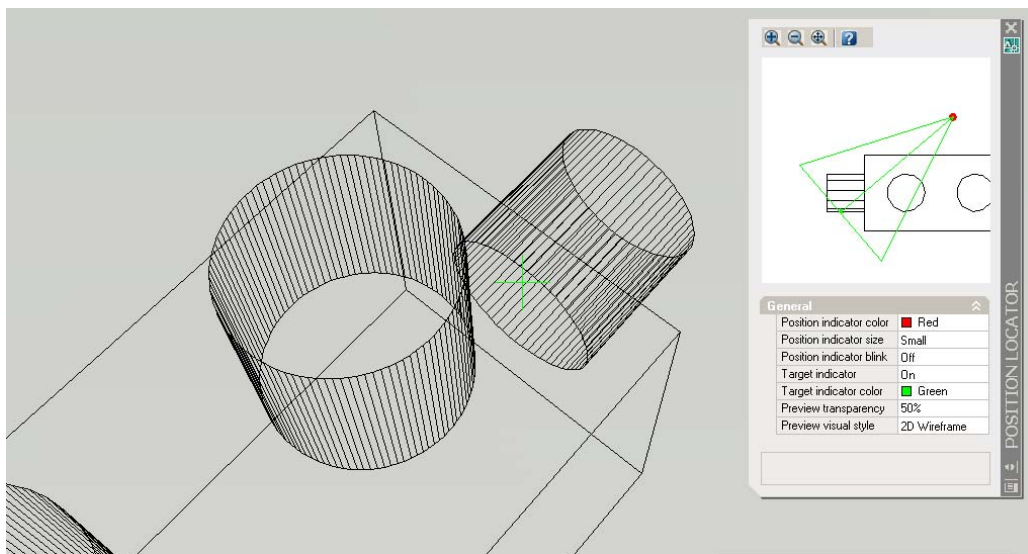

Close the Position Locator dialog box and try walking and flying using only the keys on the keyboard and mouse.

AutoCAD 3D Tutorial

7.9 Walk and Fly Settings

1. Choose **View, Walk and Hide, Walk and Hide Settings.**
or
2. Type WALKFLYSETTINGS at the command prompt.
Command: **walkflysettings**
3. Choose one of the following settings from the Walk and Fly dialog box. If you are working in a drawing with a large architectural scale, be sure to set your drawing units to a large number, similar to the scale of the drawing.

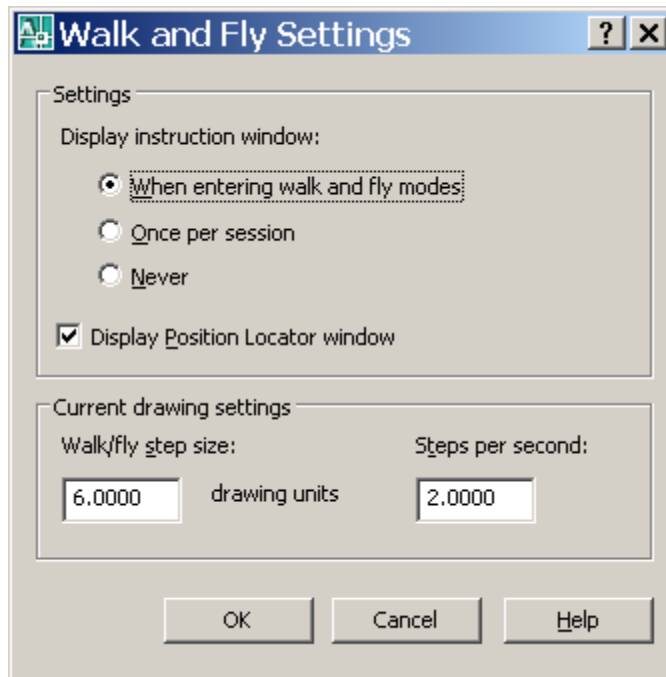

AutoCAD 3D Tutorial

7.10 Animation Paths

1. Open a drawing with 3D objects and display in a 3D view and line or polyline representing a path for an animation

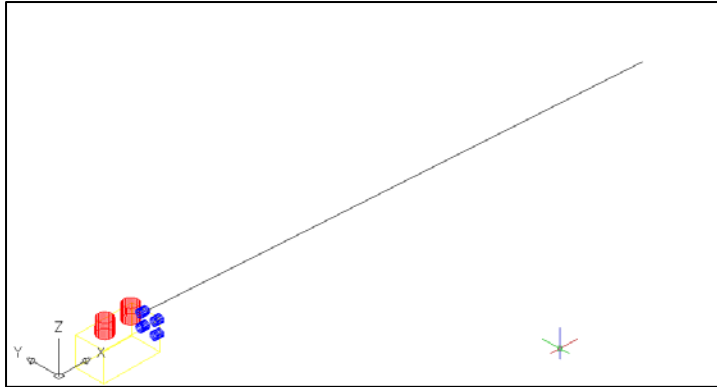

2. Choose View, Motion Path Animations.
or
3. Type ANIPATH at the command prompt.
Command: **anipath**
4. Click **Select Path** under the Link camera to: option and click on the line or polyline path.
5. Click OK to the default path name.
6. Click **Select Path** under the Link target to: option and click on the line or polyline path.
7. Click OK to the default path name.
8. Change other animation settings such as the frames per second, duration, resolution, etc.

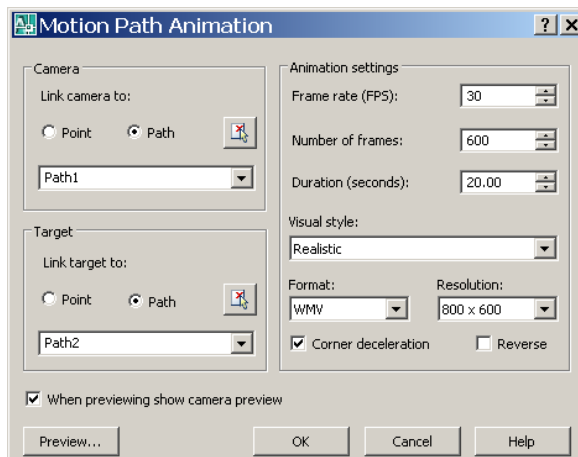

AutoCAD 3D Tutorial

9. Choose the Preview...button to preview your animation.

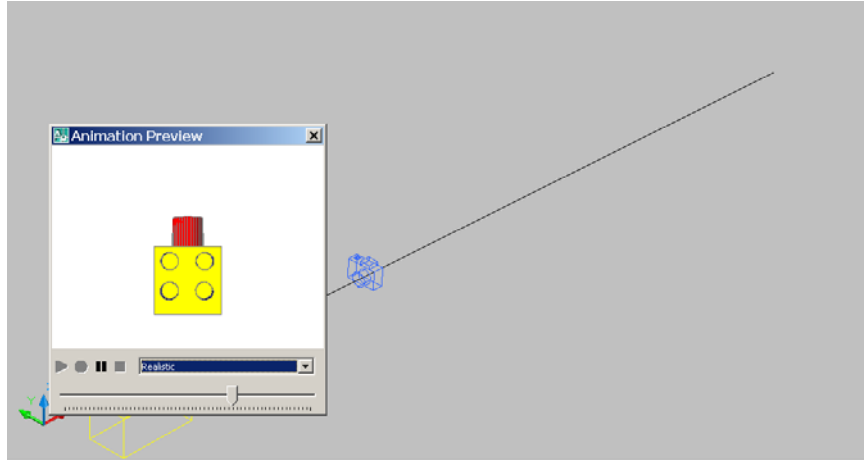

10. Close the animation preview and click OK to create an animation file.

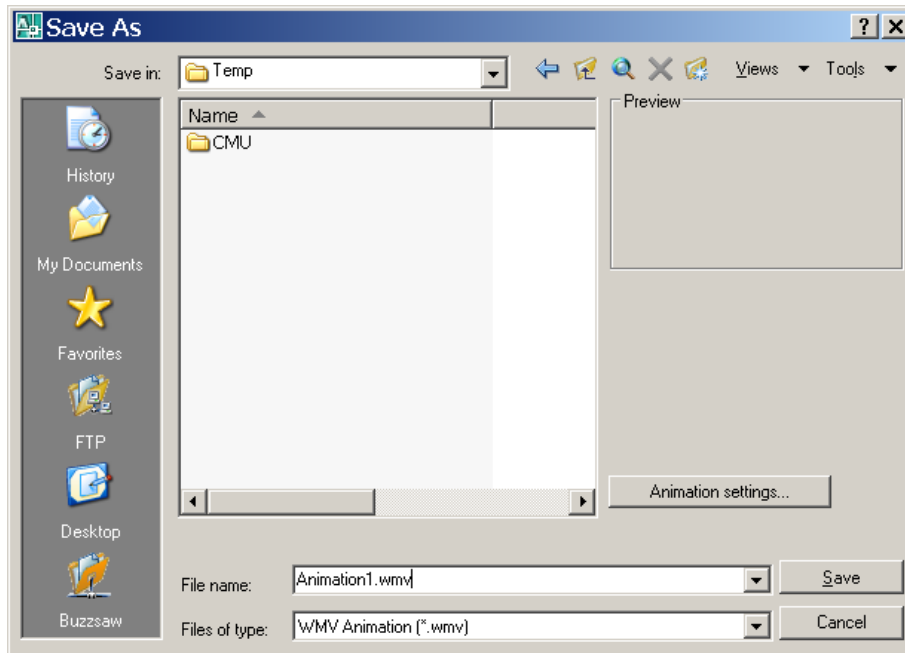

11. Play your animation in a Windows or Macintosh video review application.

7.11 3D Navigation Using the Dashboard

Regenerates a three-dimensional model with hidden lines

1. Choose **Tools, Palettes, Dashboard**.
or
2. Type DASHBOARD at the command prompt.
Command: **dashboard**

AutoCAD 3D – Chapter 8
3D Model Objects

AutoCAD 3D Tutorial

8.1 Wireframes

A wireframe model is a skeletal description of a 3D object. There are no surfaces in a wireframe model; it consists only of points, lines, and curves that describe the edges of the object. With AutoCAD you can create wireframe models by positioning 2D objects anywhere in 3D space. AutoCAD also provides some 3D wireframe objects, such as 3D polylines (that can only have a CONTINUOUS linetype) and splines. Because each object that makes up a wireframe model must be independently drawn and positioned, this type of modeling can be the most time-consuming.

Wireframe lines in 3D

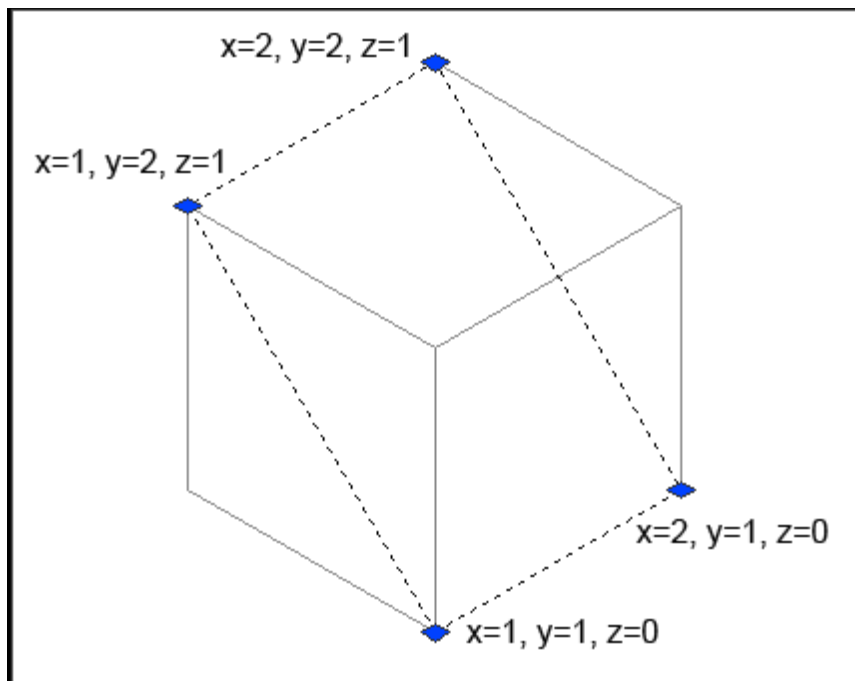

AutoCAD 3D Tutorial

8.2 Surfaces

Surface modeling is more sophisticated than wireframe modeling in that it defines not only the edges of a 3D object, but also its surfaces. The AutoCAD surface modeler defines faceted surfaces using a polygonal mesh. Because the faces of the mesh are planar, the mesh can only approximate curved surfaces.

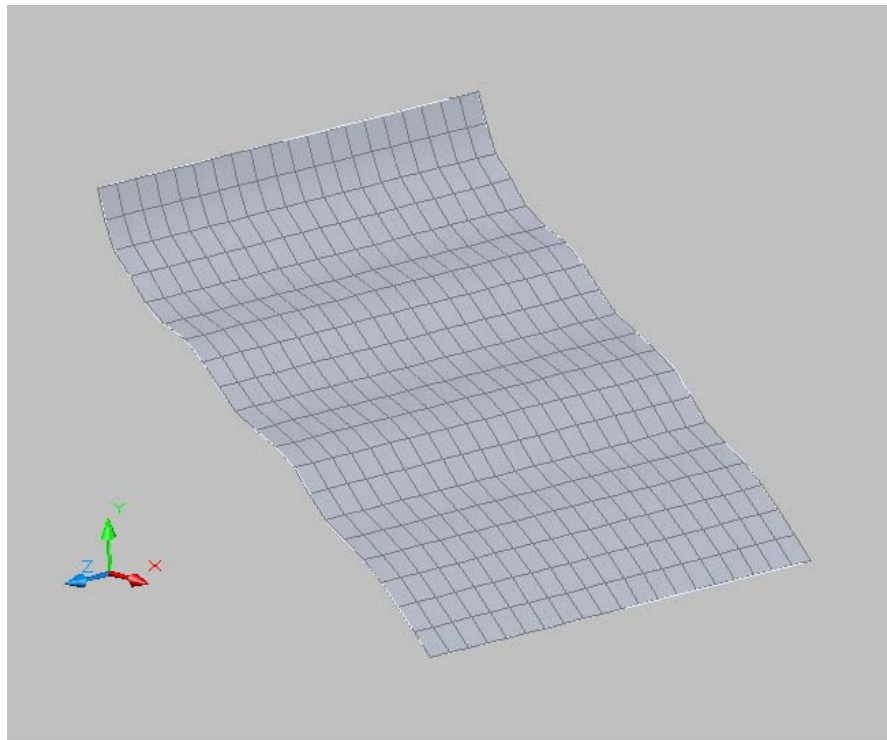

AutoCAD 3D Tutorial

8.3 Solids

Solid modeling is the easiest type of 3D modeling to use. With the AutoCAD solid modeler, you can make 3D objects by creating basic 3D shapes: boxes, cones, cylinders, spheres, wedges, and tori (do-nuts). You can then combine these shapes to create more complex solids by joining or subtracting them or finding their intersecting (overlapping) volume. You can also create solids by sweeping a 2D object along a path or revolving it about an axis.

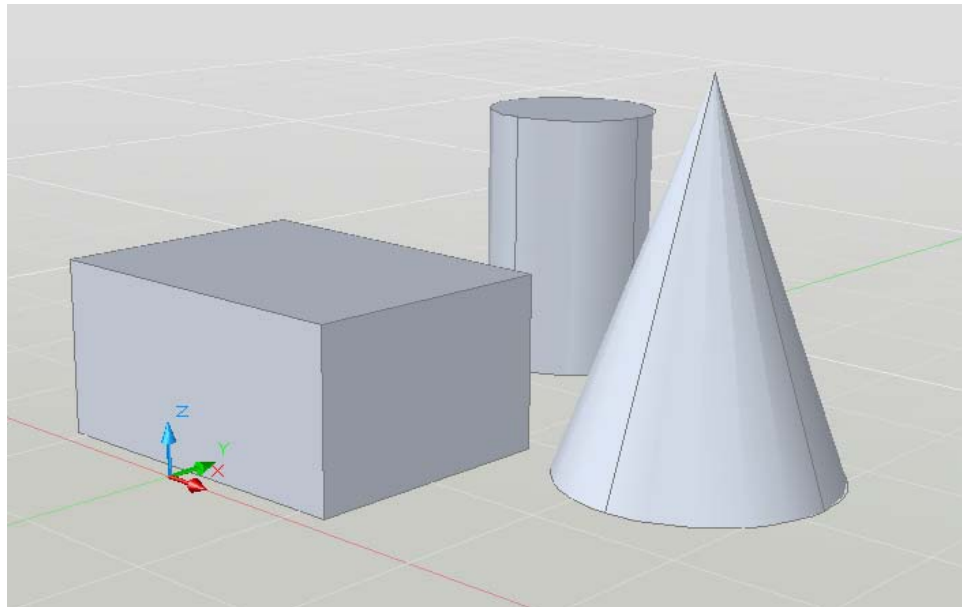

**AutoCAD 3D – Chapter 9
2D Solids and 3D Faces**

AutoCAD 3D Tutorial

9.1 2D Solid

Creates solid-filled triangles and quadrilaterals.

1. Type SOLID at the command prompt.

Command: **solid**

First point: **P1**

Second point: **P2**

Third point: **P3**

Fourth point: **P4**

Third point: **enter**

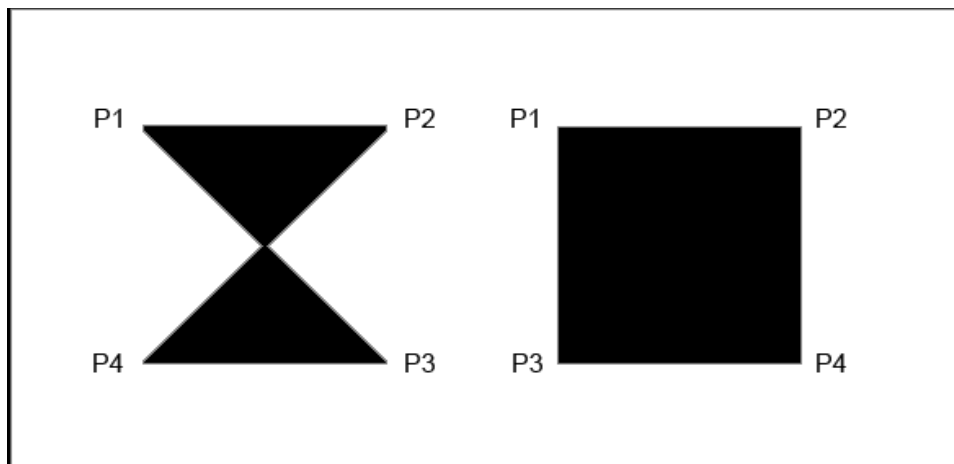

AutoCAD 3D Tutorial

9.2 3D Faces

3DFACE creates a three or four sided surface anywhere in 3D space. You can specify different Z coordinates for each corner point of a 3D face. 3DFACE differs from SOLID, which creates a three- or four-sided surface that is parallel to the current UCS and can be extruded.

1. Type 3DFACE at the command prompt.

Command: **3dface**

First point: **pick**

Second point: **pick**

Third point: **pick**

Fourth point: **pick**

Third point: **enter**

3D Wireframe Lines

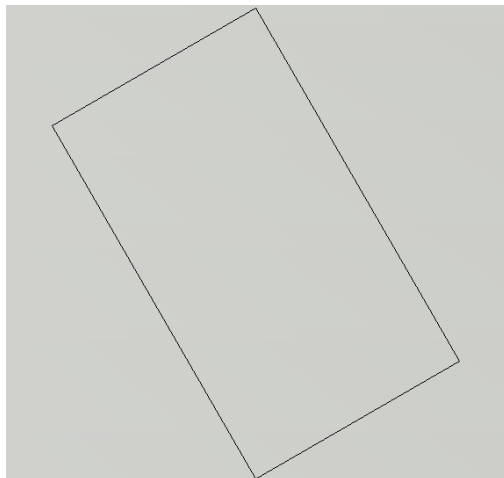

3D Face

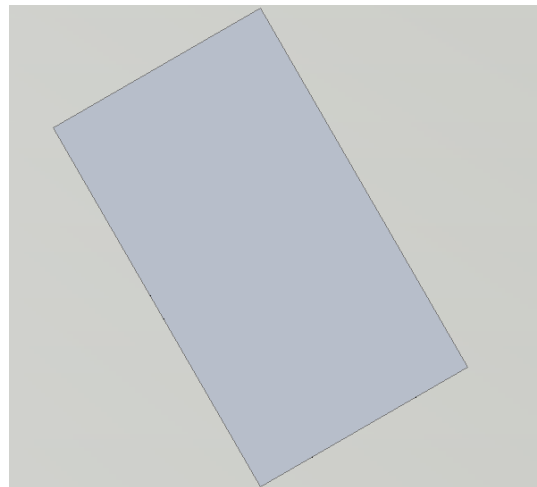

AutoCAD 3D Tutorial

9.3 3D Face Invisible Edge

With 3DFACE, you control which edges of a 3D face are visible, allowing accurate modeling of objects with holes. Entering *i* or invisible before the first point of an edge makes the edge invisible. Type 3DFACE at the command prompt.

1. Type 3DFACE at the command prompt.

Command: **3Dface**

First point: **P1**

Second point: **P2**

Third point: **i P3**

Fourth point: **P4**

Third point: **i P5**

Fourth point: **P6**

Third point: **P7**

Fourth point: **P8**

Third point: **enter**

NOTE: You must enter an "i" for invisible before the face is chosen.

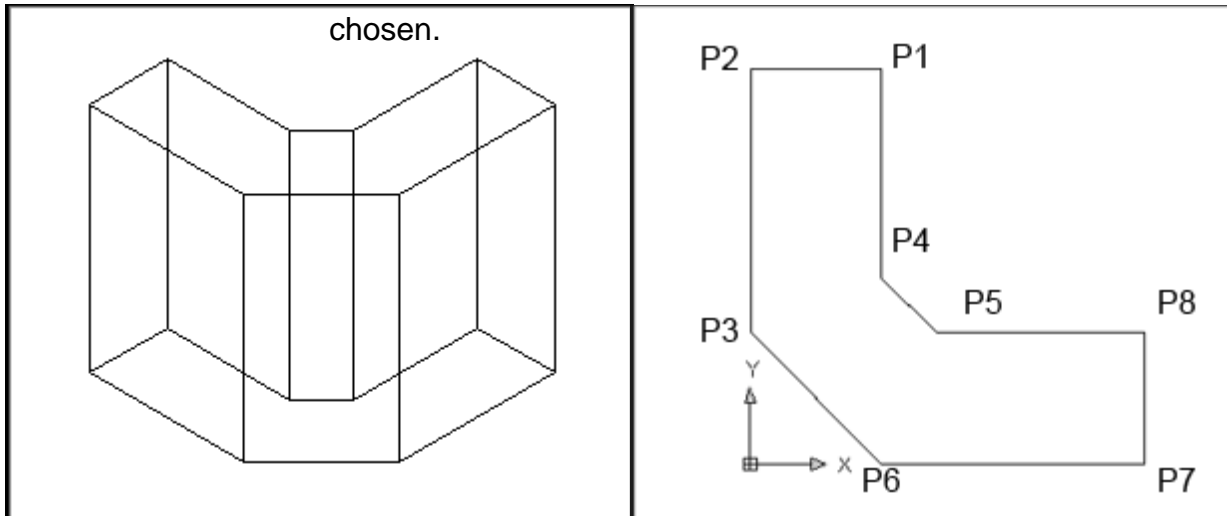

AutoCAD 3D Tutorial

9.4 Edge Command

1. Type EDGE at the command prompt.

Command: **edge**

Specify edge of 3dface to toggle visibility or [Display]: **pick edge**

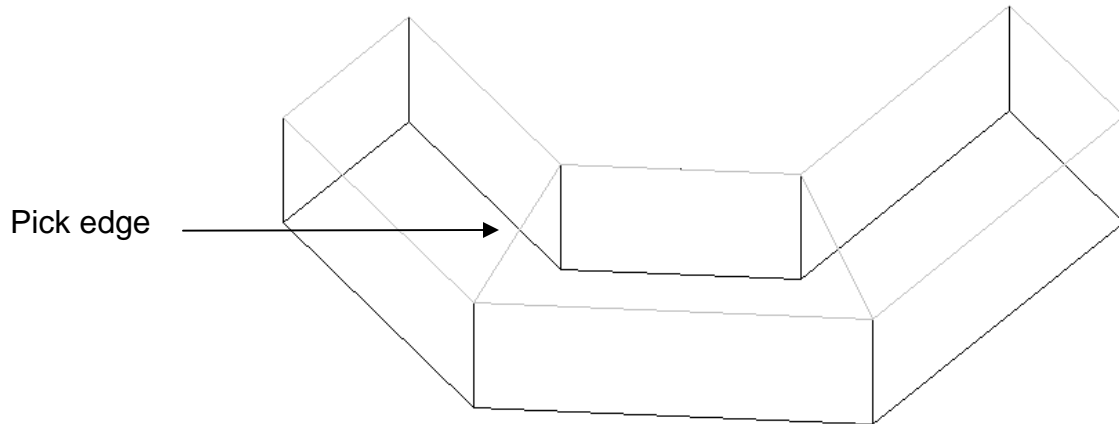

Specify edge of 3dface to toggle visibility or [Display]: **d**

Enter selection method for display of hidden edges [Select/All]

<All>: **a**

** Regenerating 3DFACE objects...done.

Specify edge of 3dface to toggle visibility or [Display]: **press enter**

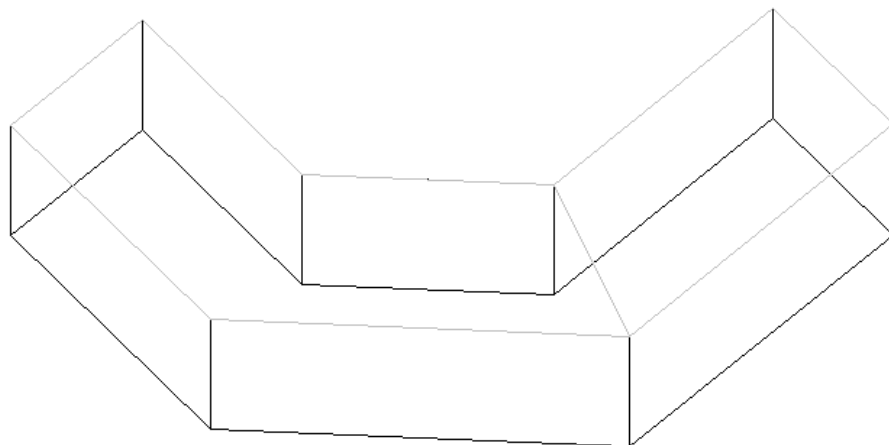

AutoCAD 3D Tutorial

9.5 PFace

Creates a three-dimensional polyface mesh vertex by vertex

1. Type PFACE at the command prompt.

Command: pface

Specify location for vertex 1: **pick point 1**

Specify location for vertex 2 or <define faces>: **pick point 2**

Specify location for vertex 3 or <define faces>: **pick point 3**

Specify location for vertex 4 or <define faces>: **pick point 4**

Specify location for vertex 5 or <define faces>: **pick point 5**

Specify location for vertex 6 or <define faces>: **pick point 6**

Specify location for vertex 7 or <define faces>: **pick point 7**

Specify location for vertex 8 or <define faces>: **enter**

Face 1, vertex 1:

Enter a vertex number or [Color/Layer]: **type 1**

Face 1, vertex 2:

Enter a vertex number or [Color/Layer] <next face>: **type 2**

Face 1, vertex 3:

Enter a vertex number or [Color/Layer] <next face>: **type 6**

Face 1, vertex 4:

Enter a vertex number or [Color/Layer] <next face>: **type 7**

Face 1, vertex 5: **enter**

Enter a vertex number or [Color/Layer] <next face>:

Face 2, vertex 1:

Enter a vertex number or [Color/Layer]: **type 2**

Face 2, vertex 2:

Enter a vertex number or [Color/Layer] <next face>: **type 3**

Face 2, vertex 3:

Enter a vertex number or [Color/Layer] <next face>: **type 4**

Face 2, vertex 4:

AutoCAD 3D Tutorial

Enter a vertex number or [Color/Layer] <next face>: **type 6**

Face 2, vertex 5:

Enter a vertex number or [Color/Layer] <next face>:

Face 3, vertex 1:

Enter a vertex number or [Color/Layer]: **type 4**

Face 3, vertex 2:

Enter a vertex number or [Color/Layer] <next face>: **type 5**

Face 3, vertex 3:

Enter a vertex number or [Color/Layer] <next face>: **type 6**

Face 3, vertex 4:

Enter a vertex number or [Color/Layer] <next face>:

Face 4, vertex 1: **enter**

Enter a vertex number or [Color/Layer]:

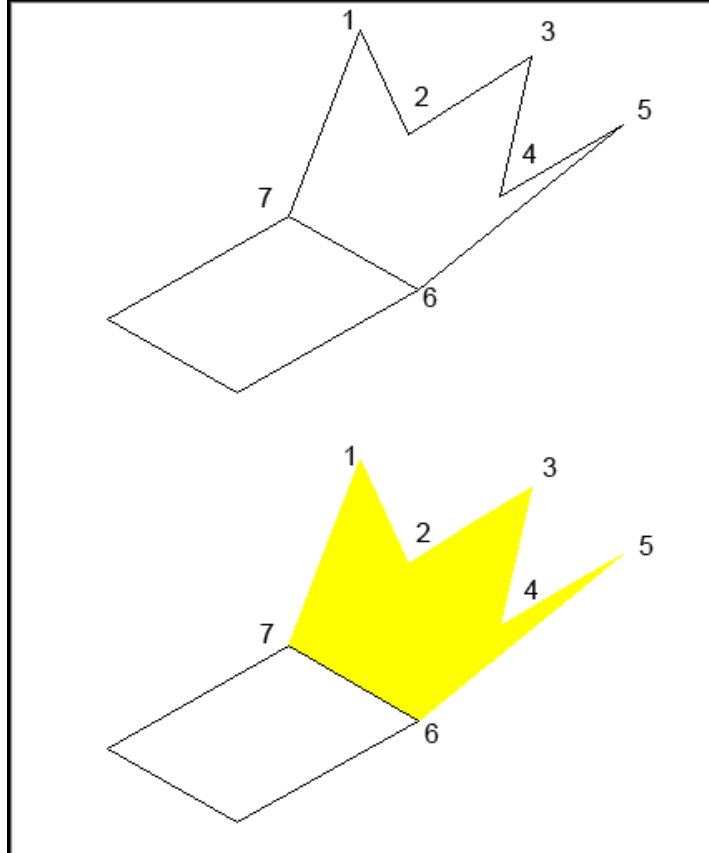

AutoCAD 3D – Chapter 10
Basic 3D Surfaces

AutoCAD 3D Tutorial

10.0 Surface Commands (Solid Panel)

1. Click the **3D Modeling** dropdown option from the Solids panel.

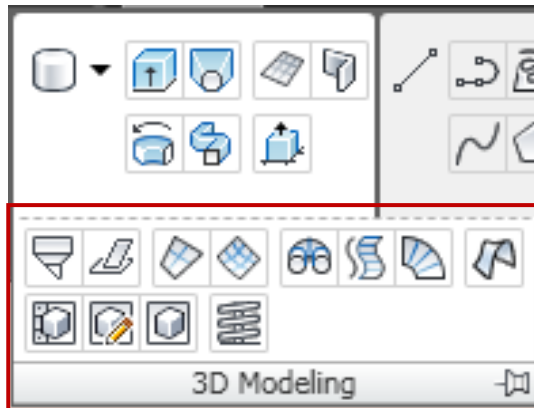

AutoCAD 3D Tutorial

10.1 Box

2. Type AI_BOX at the command prompt.
Command: **ai_box**
Initializing... 3D Objects loaded. Corner of box: **pick point**
Specify length of box: **4**
Specify width of box or [Cube]: **2**
Specify height of box: **2**
Specify rotation angle of box about the Z axis or [Reference]: **0**

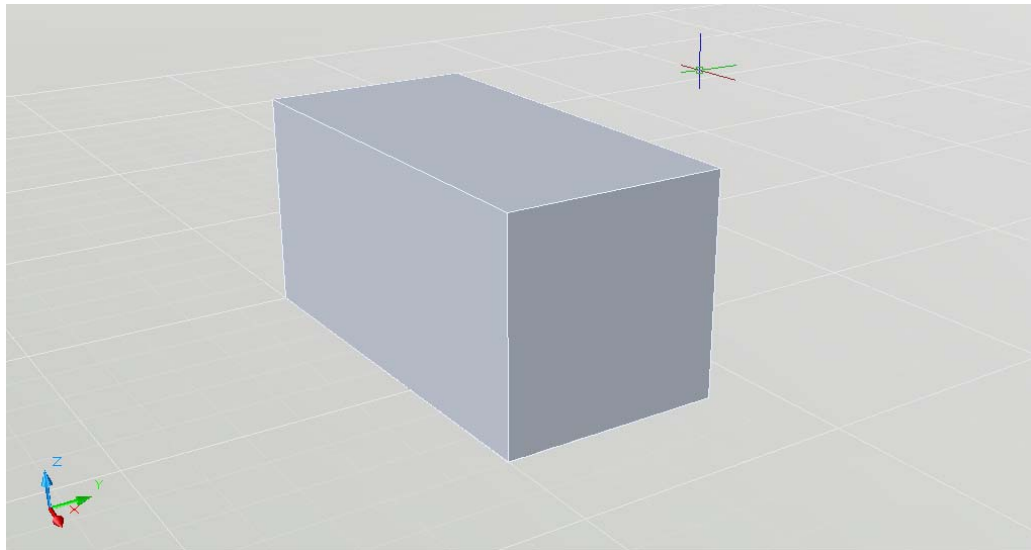

AutoCAD 3D Tutorial

10.2 Pyramid

1. Type AI_PYRAMID at the command prompt.
Command: **ai_pyramid**
Specify first corner point for base of pyramid: **pick point**
Specify second corner point for base of pyramid:
<Ortho on> **4**
Specify third corner point for base of pyramid: **4**
Specify fourth corner point for base of pyramid or
[Tetrahedron]: **4**
Specify apex point of tetrahedron or [Top]: **.xy**
of pick
(need Z): **4**

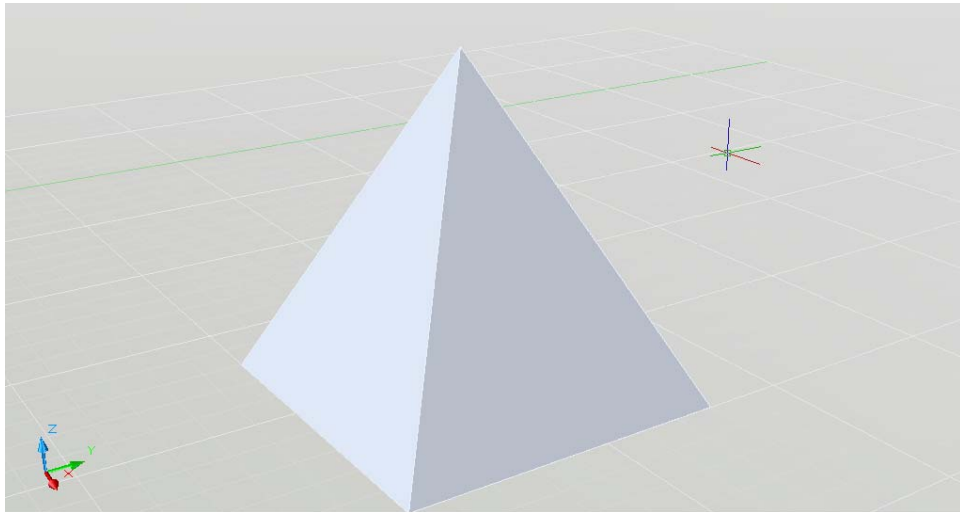

AutoCAD 3D Tutorial

10.3 Wedge

1. Type AI_WEDGE at the command prompt.

Command: **ai_wedge**

Specify corner point of wedge: **pick point**

Specify length of wedge: **4**

Specify width of wedge: **2**

Specify height of wedge: **2**

Specify rotation angle of wedge about the Z axis: **0**

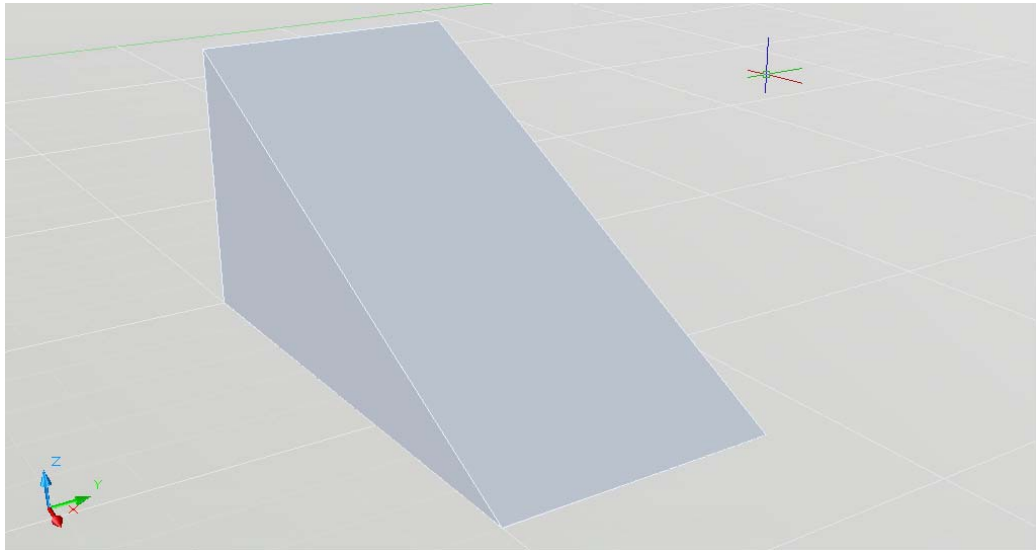

AutoCAD 3D Tutorial

10.4 Dome

1. Type AI_DOME at the command prompt.
Command: **ai_dome**
Specify center point of dome: **pick point**
Specify radius of dome or [Diameter]: **3**
Enter number of longitudinal segments for surface of dome <16>:
20
Enter number of latitudinal segments for surface of dome
<8>: **10**

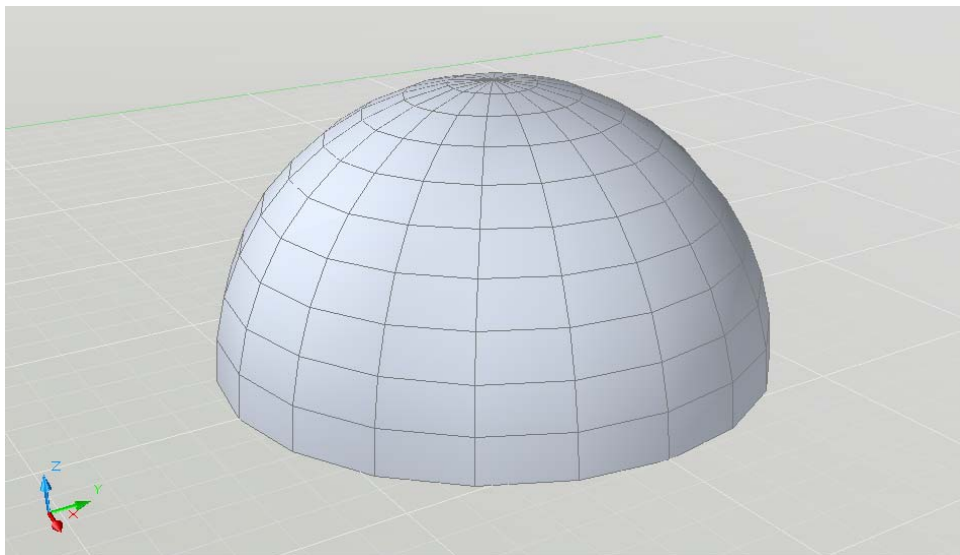

AutoCAD 3D Tutorial

10.5 Sphere

1. Type AI_SPHERE at the command prompt.

Command: **ai_sphere**

Specify center point of sphere: **pick point**

Specify radius of sphere or [Diameter]: **3**

Enter number of longitudinal segments for surface of sphere <16>:
25

Enter number of latitudinal segments for surface of sphere <16>: **25**

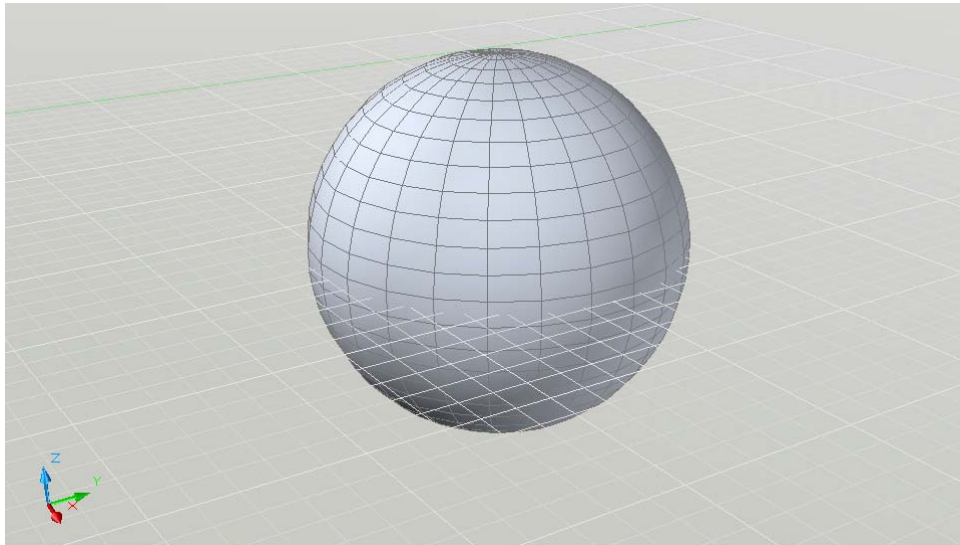

AutoCAD 3D Tutorial

10.6 Cone

1. Type AI_CONE at the command prompt.

Command: **ai_cone**

Specify center point for base of cone: **pick point**

Specify radius for base of cone or [Diameter]: **2**

Specify radius for top of cone or [Diameter] <0>: **5**

Specify height of cone: **3**

Enter number of segments for surface of cone <16>:

enter

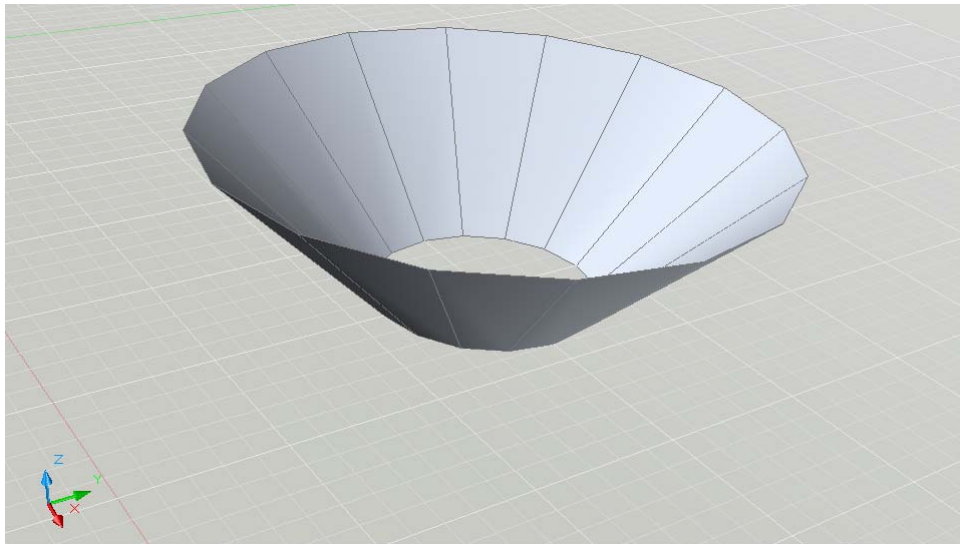

AutoCAD 3D Tutorial

10.7 Torus

1. Type AI_TORUS at the command prompt.

Command: **ai_torus**

Specify center point of torus: **pick point**

Specify radius of torus or [Diameter]: **6**

Specify radius of tube or [Diameter]: **1**

Enter number of segments around tube circumference

<16>: **enter**

Enter number of segments around torus circumference

<16>: **enter**

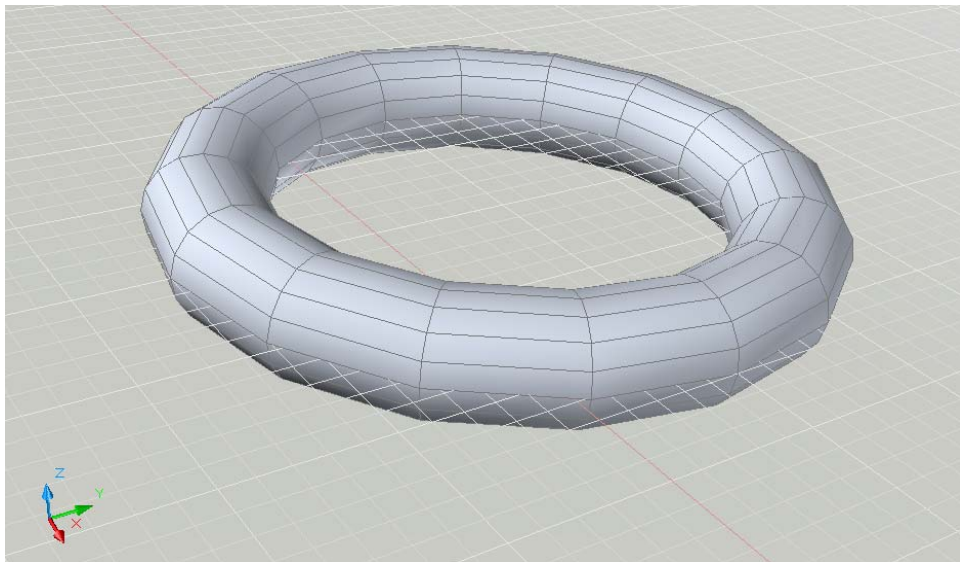

AutoCAD 3D Tutorial

10.8 Dish

1. Type AI_DISH at the command prompt.

Command: **ai_dish**

Specify center point of dish: **pick point**

Specify radius of dish or [Diameter]: **3**

Enter number of longitudinal segments for surface of dish

<16>: **20**

Enter number of latitudinal segments for surface of dish

<8>: **15**

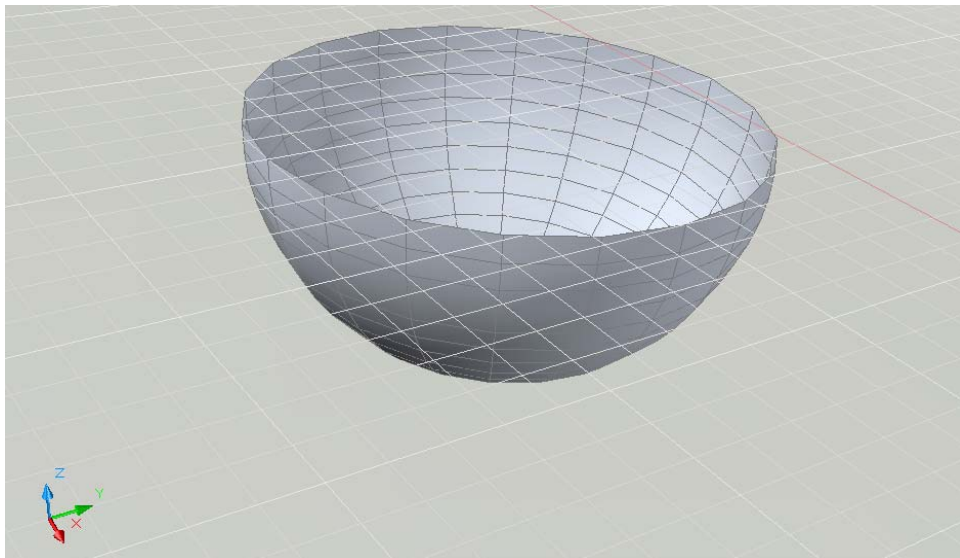

AutoCAD 3D Tutorial

10.9 Mesh

1. Type `ai_mesh` at the command prompt.

Command: **ai_mesh**

Initializing... 3D Objects loaded. Specify first corner point of mesh: **1,1,1**

Specify second corner point of mesh: **4,1,1**

Specify third corner point of mesh: **4,4,2**

Specify fourth corner point of mesh: **1,4,1**

Enter mesh size in the M direction: **20**

Enter mesh size in the N direction: **10**

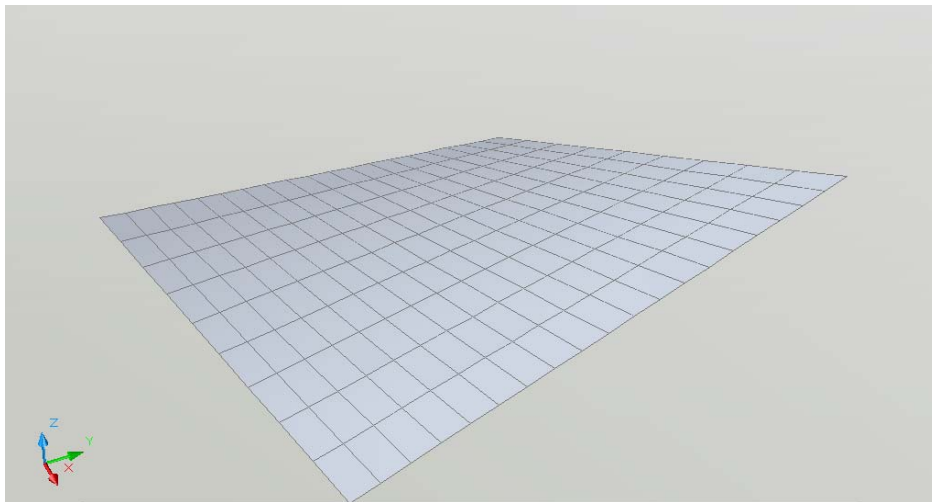

AutoCAD 3D – Chapter 11
Complex Surfaces

AutoCAD 3D Tutorial

11.1 Revolved Surfaces

Regenerates a three-dimensional model with hidden lines

1. Type Revsurf at the command prompt.

Command: **revsurf**

Current wire frame density: SURFTAB1=6 SURFTAB2=6

Select object to revolve: **pick path curve**

Select object that defines the axis of revolution: **pick line**

Specify start angle <0>: **enter**

Specify included angle (+=ccw, -=cw) <360>: **enter**

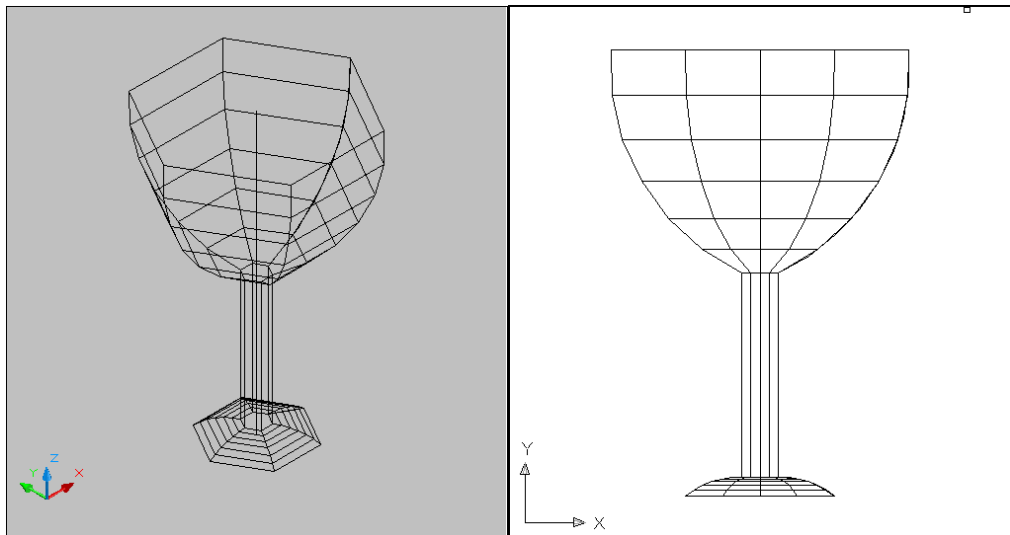
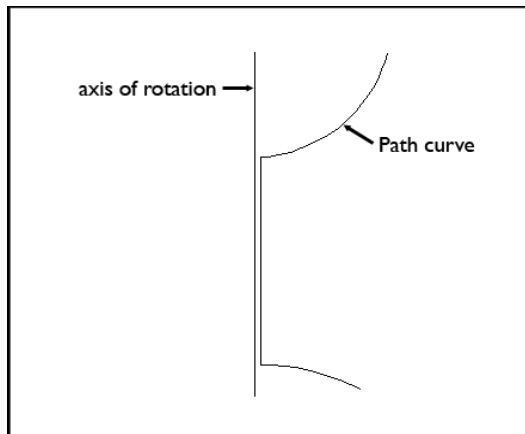

AutoCAD 3D Tutorial

11.2 Surftab Variables

Sets the number of tabulations for both directions to be generated for RULESURF and TABSURF. Also sets the mesh density in ROTATE3D the M direction for REVSURF and EDGESURF commands.

1. Type Surftab1 at the command prompt.
Command: **surftab1**
Enter new value for SURFTAB1 <6>: **30**
2. Type Surftab2 at the command prompt.
Command: **surftab2**
Enter new value for SURFTAB2 <6>: **30**
3. Type Revsurf at the command prompt.

Command: **revsurf**

Current wire frame density: SURFTAB1=30 SURFTAB2=30

Select object to revolve: **pick path curve**

Select object that defines the axis of revolution: **pick line**

Specify start angle <0>: **enter**

Specify included angle (+=ccw, -=cw) <360>: **enter**

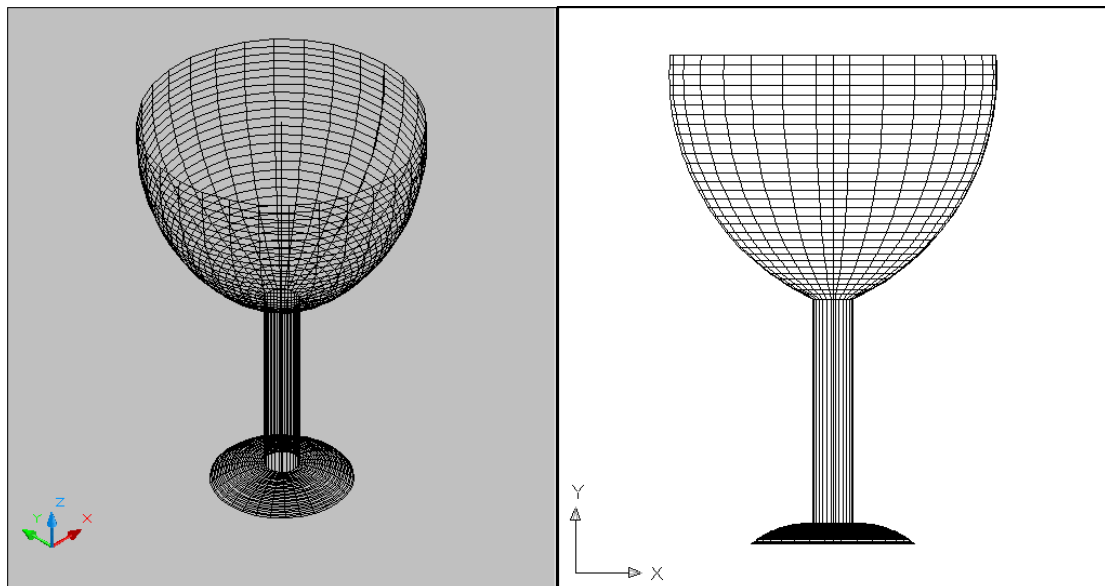

11.3 Tabulated Surfaces

1. Type TABSURF at the command prompt.

Command: **tabsurf**

Select object for path curve: Select object for direction vector:

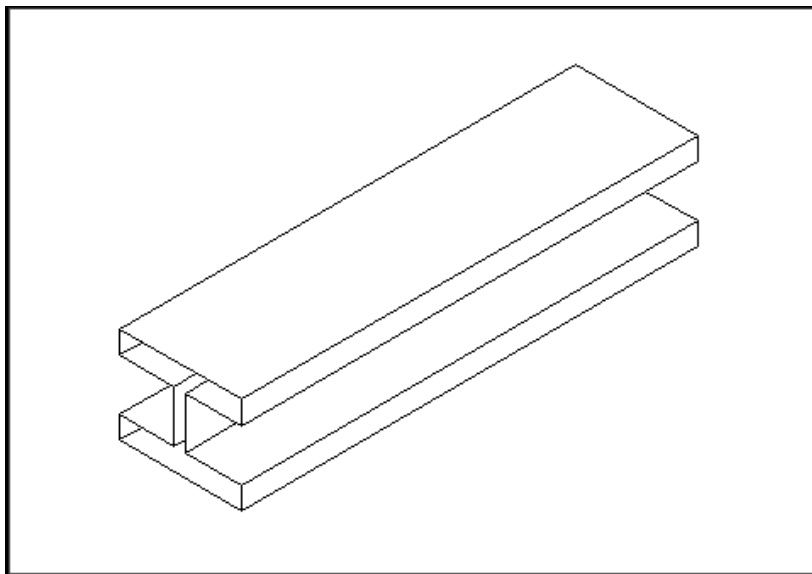
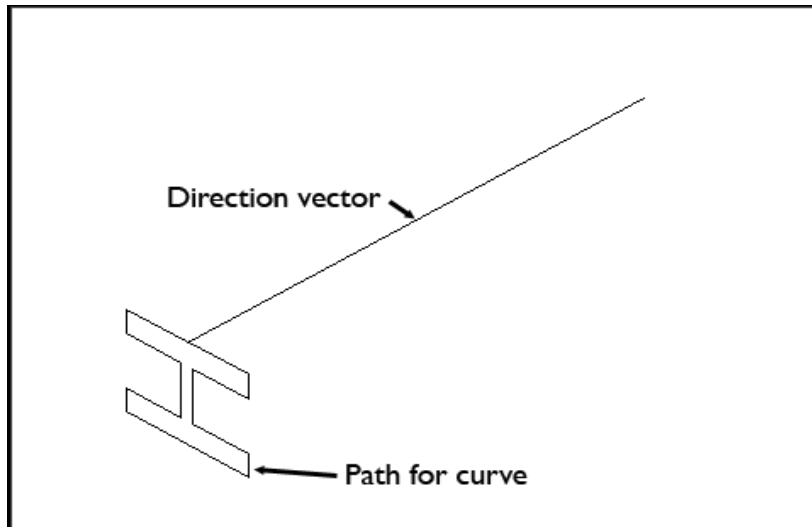

AutoCAD 3D Tutorial

11.4 Ruled Surfaces

1. Type RULESURF at the command prompt.

Command: **rulesurf**

Current wire frame density: SURFTAB1=6

Select first defining curve: **P1**

Select second defining curve: **P2**

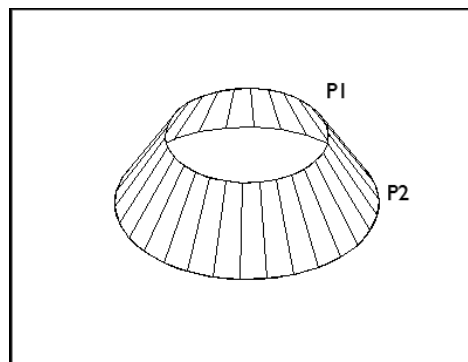
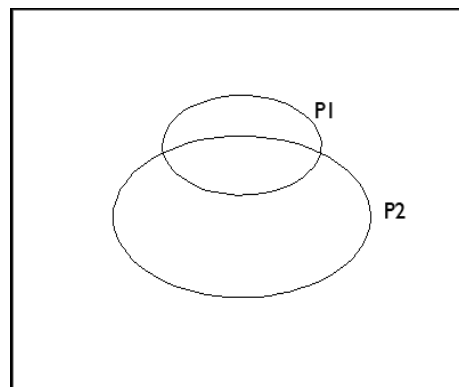
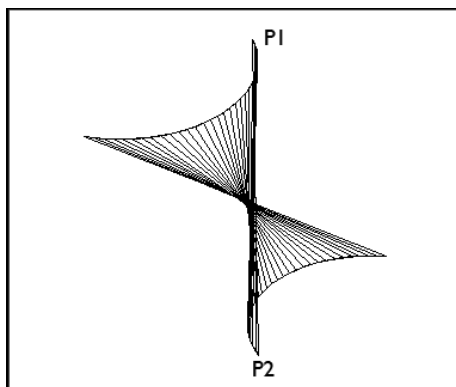
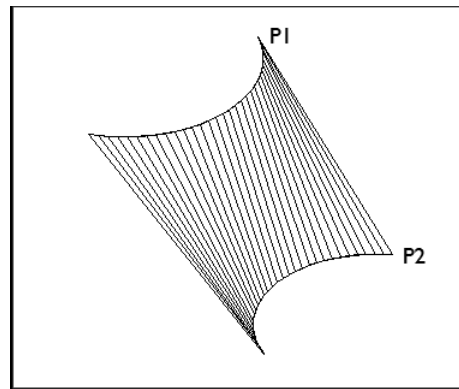
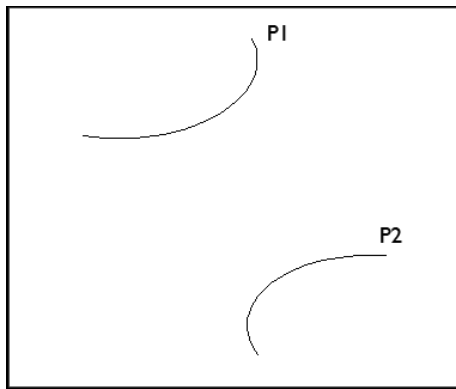

AutoCAD 3D Tutorial

11.5 Edge Surfaces

Regenerates a three-dimensional model with hidden lines

1. Type EDGESURF at the command prompt.

Command: **edgesurf**

Current wire frame density: SURFTAB1=20 SURFTAB2=10

Select object 1 for surface edge: **P1**

Select object 2 for surface edge: **P2**

Select object 3 for surface edge: **P3**

Select object 4 for surface edge: **P4**

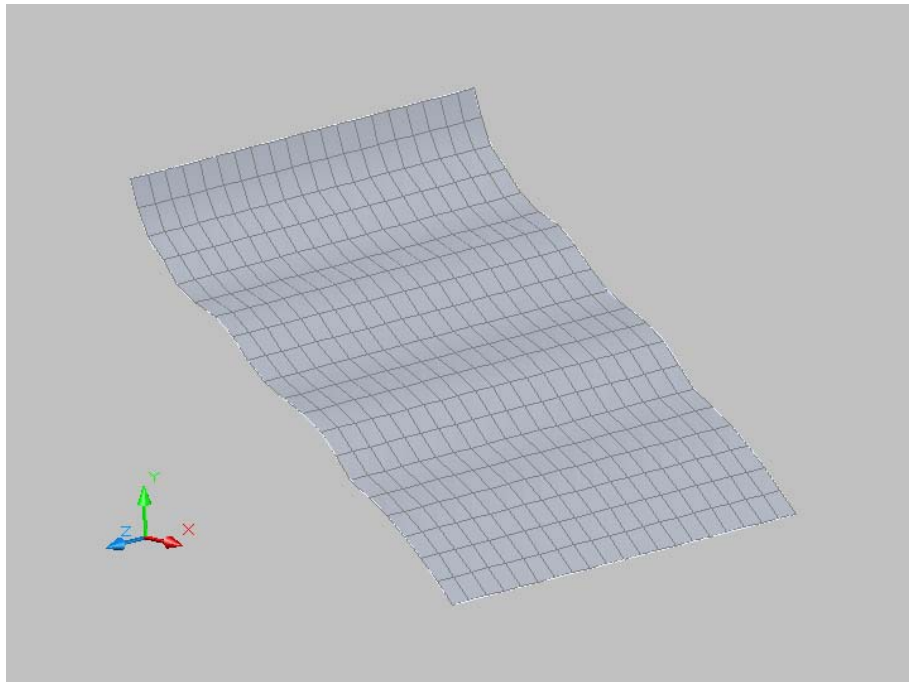

AutoCAD 3D Tutorial

11.6 Helix

Creates a 2D or 3D spiral.

1. Begin a new drawing.
2. Choose **Draw, Helix**.
- or
3. Type HELIX at the command prompt.

Command: **helix**

Number of turns = 3.0000 Twist=CCW

Specify center point of base: **pick point**

Specify base radius or [Diameter] <1.0000>: **enter or drag and pick**

Specify top radius or [Diameter] <11.0776>: **enter or drag and pick**

Specify helix height or [Axis endpoint/Turns/turn Height/tWist] <1.0000>: **enter or drag and pick**

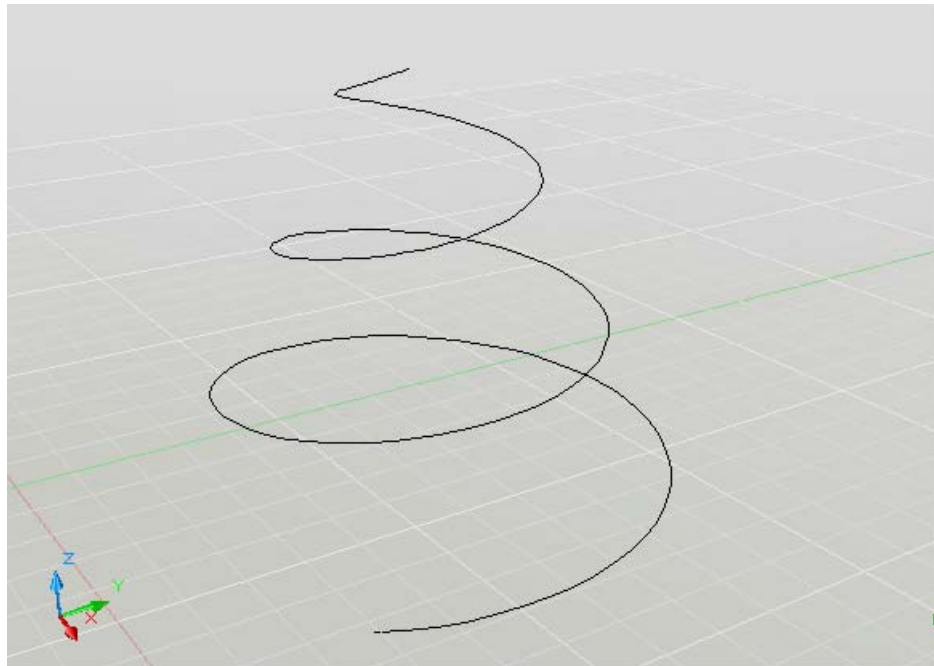

AutoCAD 3D – Chapter 12
Creating Solids

AutoCAD 3D Tutorial

12.1 Solid Primitives

Solid primitives can easily be drawn from both the Draw pulldown menu and from Autodesk's dashboard.

1. Choose **Draw, Modeling**, and one of the following solid primitives.



or

2. Choose the solid primitive from AutoCAD's Dashboard.

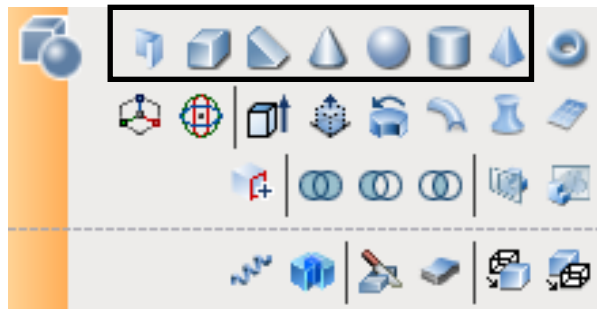

or

3. Choose the solid primitive from the 3D Modeling panel.

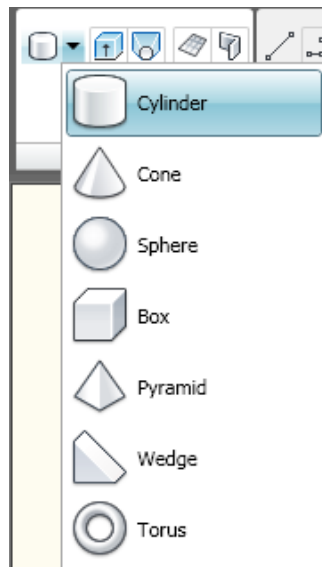

AutoCAD 3D Tutorial

12.2 Polysolid Command

With the POLYSOLID command, you can convert an existing line, 2D polyline, arc, or circle to a solid with a rectangular profile. A polysolid can have curved segments, but the profile is always rectangular by default.

1. Open a drawing with a closed 2D polyline and display in a 3D view.
2. Choose **Draw, Modeling, Polysolid**.

or

3. Type POLYSOLID at the command prompt.

Command: **polysolid**

Specify start point or [Object/Height/Width/Justify] <Object>: **h**

Specify height <0'-4">: **10'**

Specify start point or [Object/Height/Width/Justify] <Object>: **o**

Select object: **Pick polygon**

or

4. Choose Polysolid from the 3D Modeling panel.

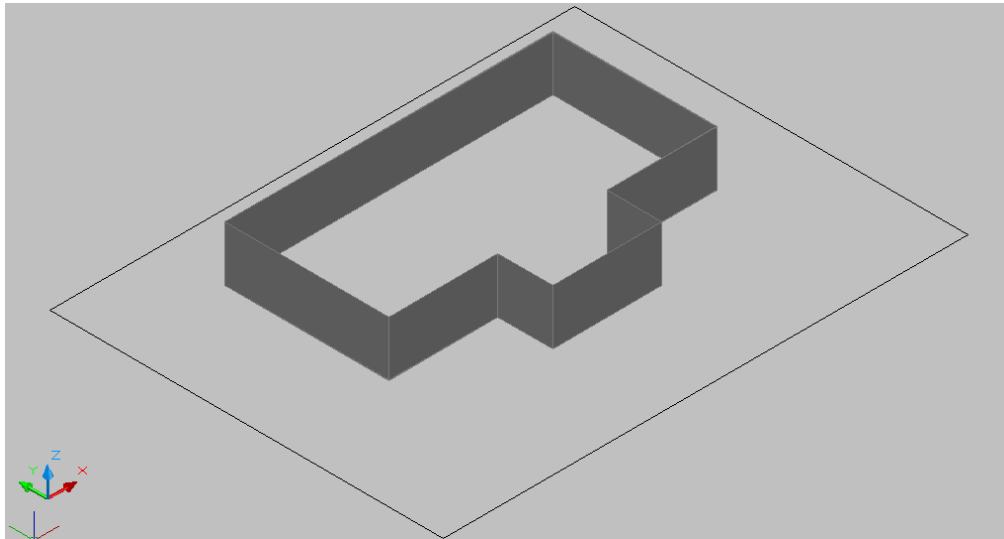

AutoCAD 3D Tutorial

12.3 Extrude

Creates unique solid primitives by extruding existing two-dimensional objects. You can extrude multiple objects with EXTRUDE.

1. Type EXTRUDE at the command prompt.

Command: **extrude**

Current wire frame density: ISOLINES=4

Select objects: **pick objects**

Select objects: **enter**

Specify height of extrusion or [Direction/Path/Taper angle]: **2**

Lines with a Thickness of 2"

Lines Extruded 2"

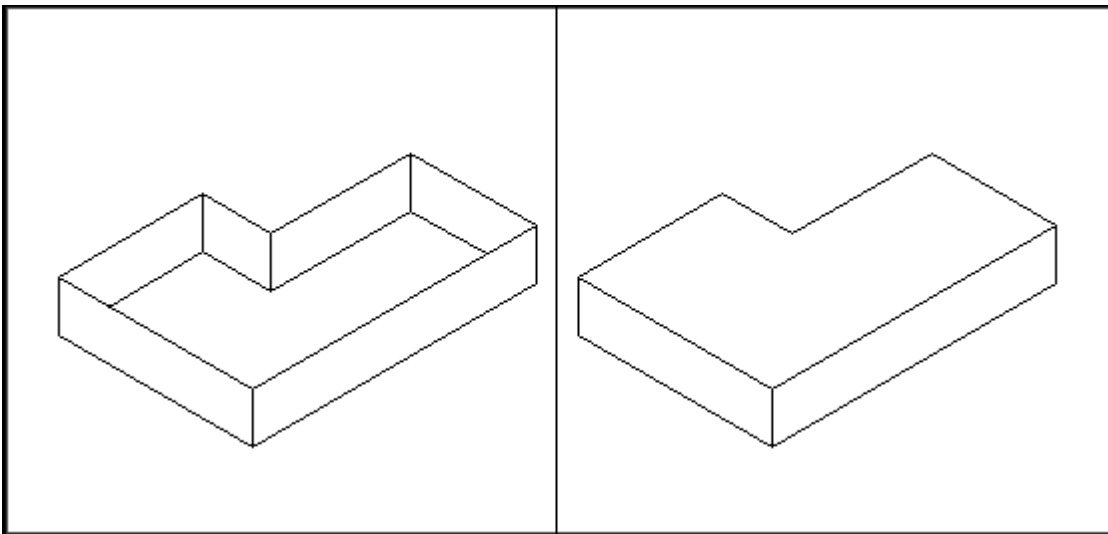

AutoCAD 3D Tutorial

12.4 Extrude with Taper

1. Choose **Draw, Modeling, Extrude.**
or
2. Type EXTRUDE at the command prompt.

Command: **extrude**

Current wire frame density: ISOLINES=4

Select objects to extrude: **pick object to extrude**

Select objects to extrude: **enter**

Specify height of extrusion or [Direction/Path/Taper angle]
<8.9509>: **T**

Specify angle of taper for extrusion <0>: **15**

Specify height of extrusion or [Direction/Path/Taper angle]
<8.9509>: **4**

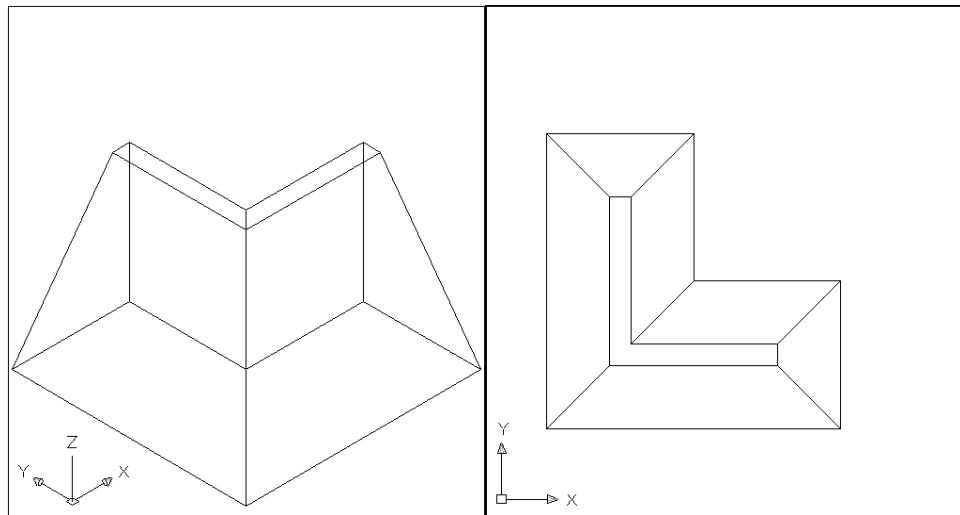

AutoCAD 3D Tutorial

12.5 Extrude with Path

1. Choose **Draw, Modeling, Extrude.**
or
2. Type EXTRUDE at the command prompt.

Command: **extrude**

Current wire frame density: ISOLINES=4

Select objects to extrude: 1 found

Select objects to extrude: **pick circle (P1)**

Specify height of extrusion or [Direction/Path/Taper angle]

<4.0000>: **p**

Select extrusion path or [Taper angle]: **pick P2**

Circle Extruded Along a Path

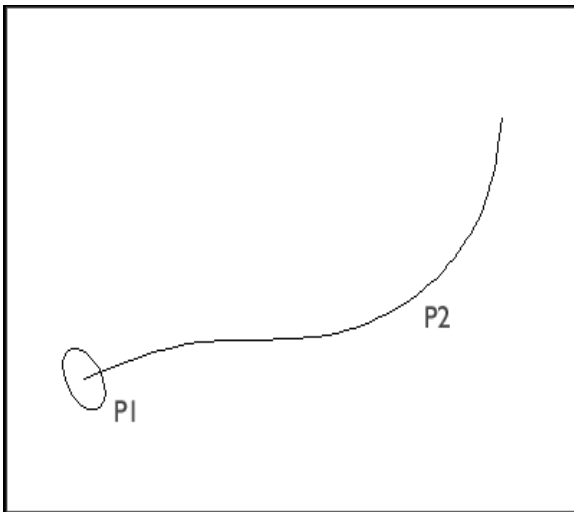

Hidden Line Removal of Extruded Circle

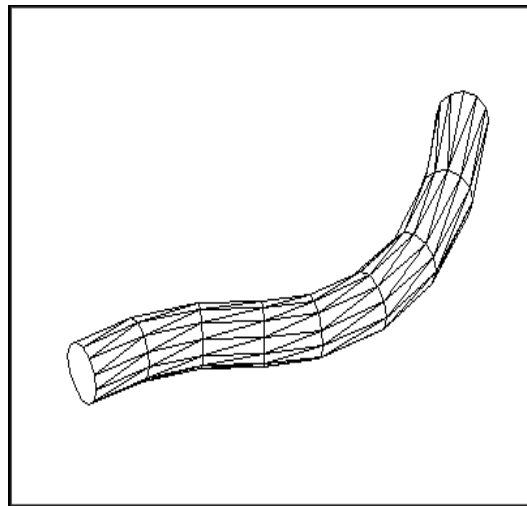

AutoCAD 3D Tutorial

12.6 Revolve Command

1. Open a drawing with 3D objects and display in a 3D view.
2. Choose **Draw, Modeling, Revolve**.
Or
3. Type REVOLVE at the command prompt.

Command: **revolve**

Current wire frame density: ISOLINES=4

Select objects: **pick profile**

Select objects: **enter**

Specify start point for axis of revolution or define axis by [Object/X

(axis)/Y (axis)]: **o**

Select an object: **pick axis**

Specify angle of revolution <360>: **enter**

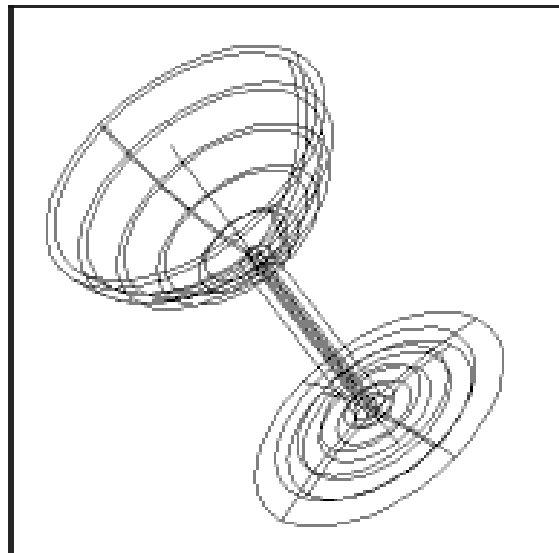
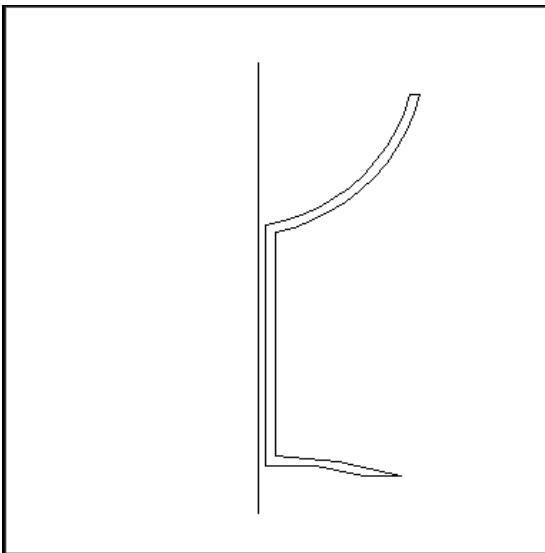

AutoCAD 3D Tutorial

12.7 Sweep Command

1. Open a drawing with 2D objects to sweep and display in a 3D view.
2. Choose **Draw, Modeling, Sweep**.

or

3. Type SWEEP at the command prompt.

Command: **sweep**

Current wire frame density: ISOLINES=4

Select objects to sweep: **pick arc**

Select objects to sweep:

Select sweep path or [Alignment/Base point/Scale/Twist]: **pick path**

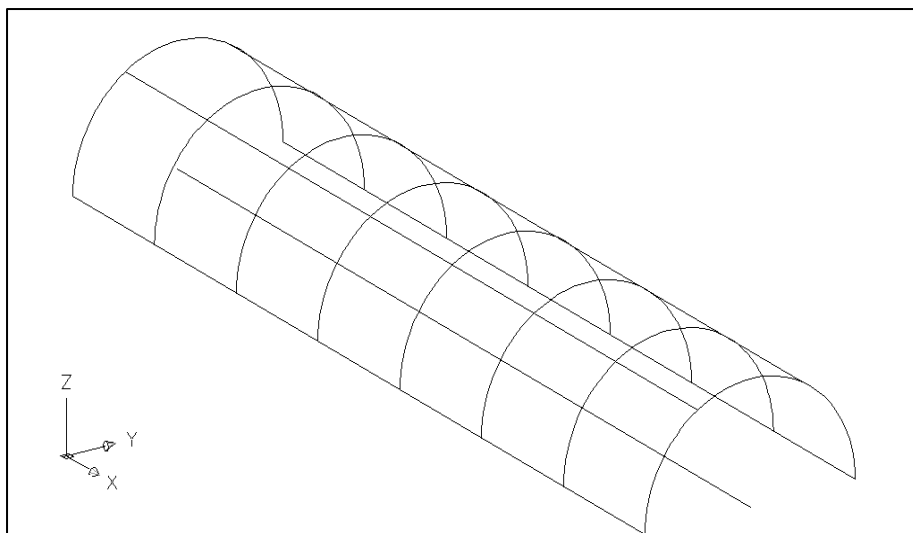
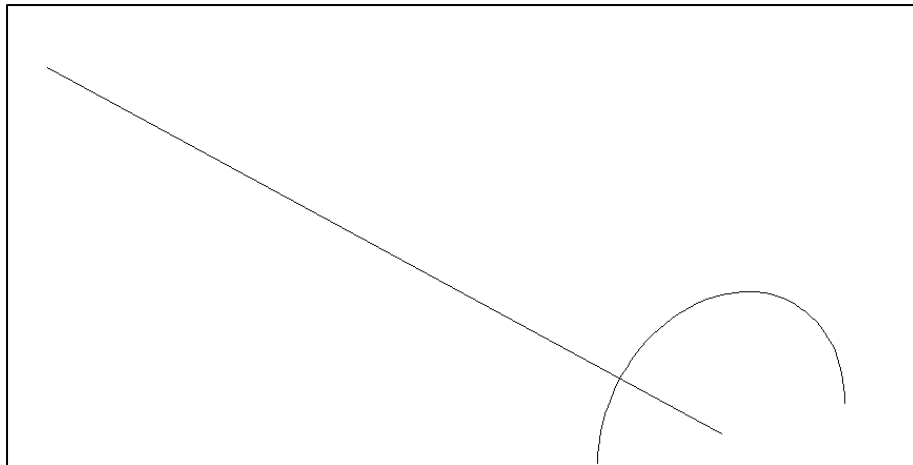

AutoCAD 3D Tutorial

12.8 Loft Command

1. Open a drawing with 2D objects to sweep and display in a 3D view.
2. Choose **Draw, Modeling, Loft**.
- or
3. Type LOFT at the command prompt.

Command: **loft**

Select cross-sections in lofting order: **pick circles**

Specify opposite corner: 5 found

Select cross-sections in lofting order:

Enter an option [Guides/Path/Cross-sections only] <Cross-sections only>: **enter**

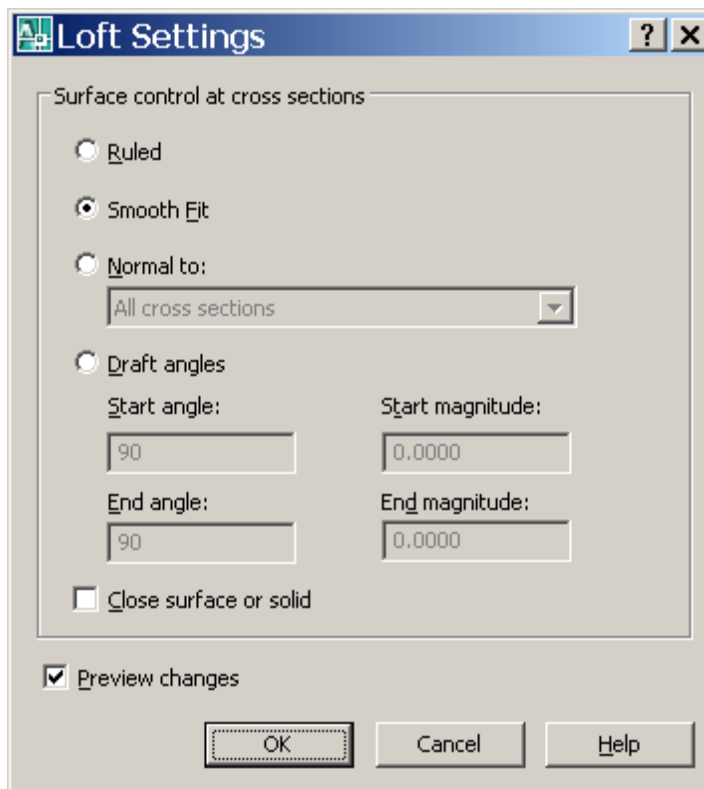

Click OK.

AutoCAD 3D Tutorial

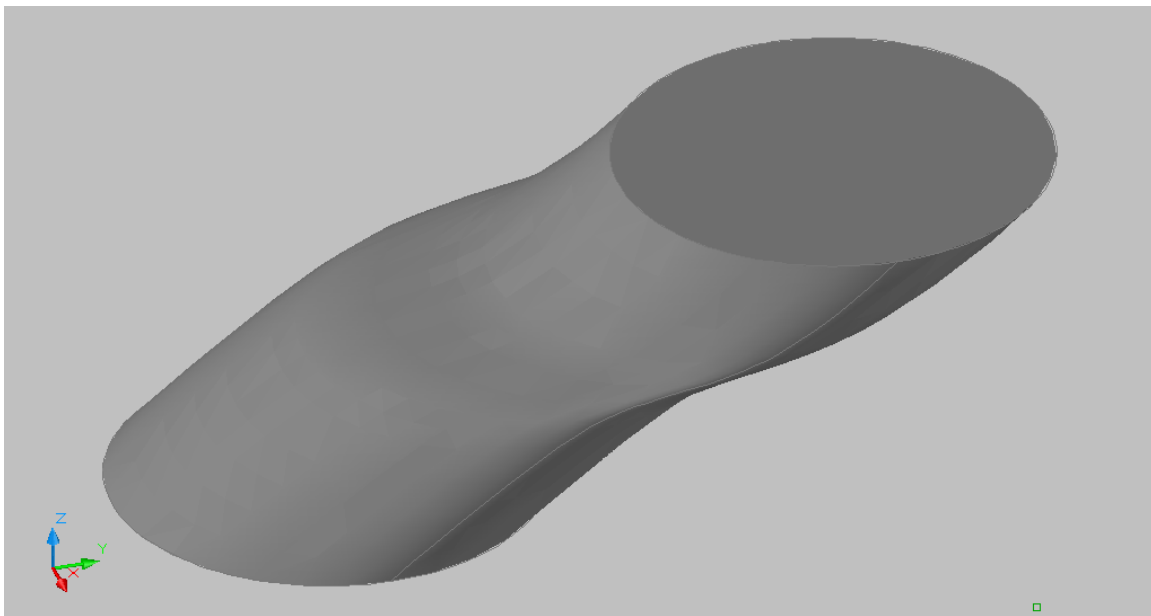
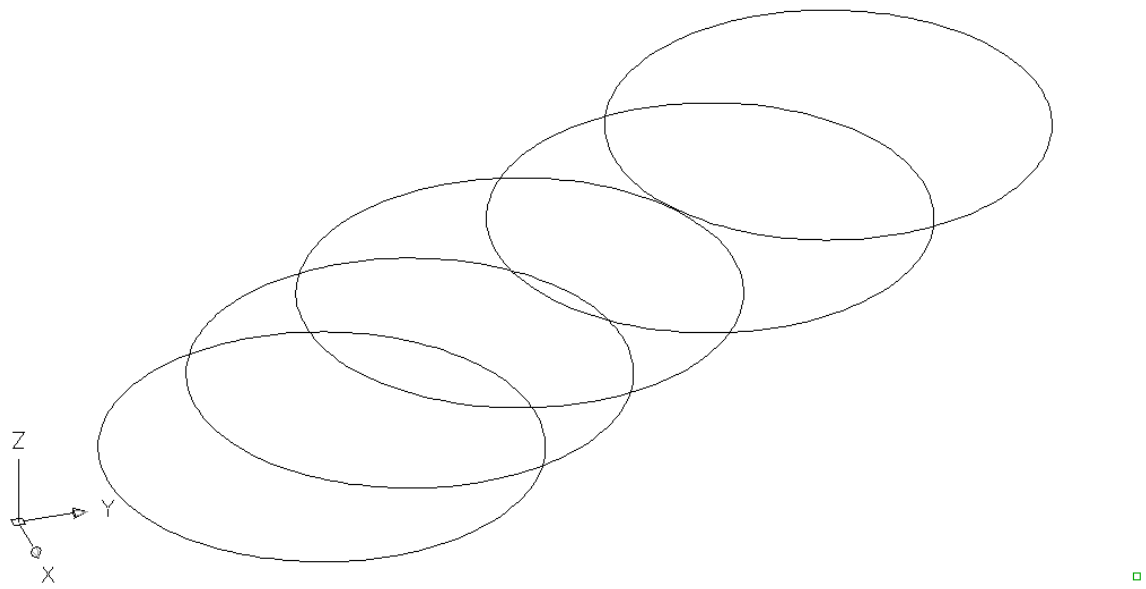

AutoCAD 3D – Chapter 13
3D Edits

AutoCAD 3D Tutorial

13.1 Convert to Solid

Converts polylines and circles with thickness to 3D solids. With the CONVTSOLID command, you can convert the following objects into extruded 3D solids:

Uniform-width wide polylines with thickness
Closed, zero-width polylines with thickness
Circles with thickness

Note You cannot use CONVTSOLID with polylines that contain vertices with 0 width or that contain segments of variable width

1. Open a drawing with 2D polylines or circles with thicknesses and display in a 3D view.
2. Choose **Modify, 3D Operation, Convert to Solid.**
or
3. Type CONVTSOLID at the command prompt.

Command: **convtsolid**

Select objects: pick circle or polyline 1 found

Select objects: press enter

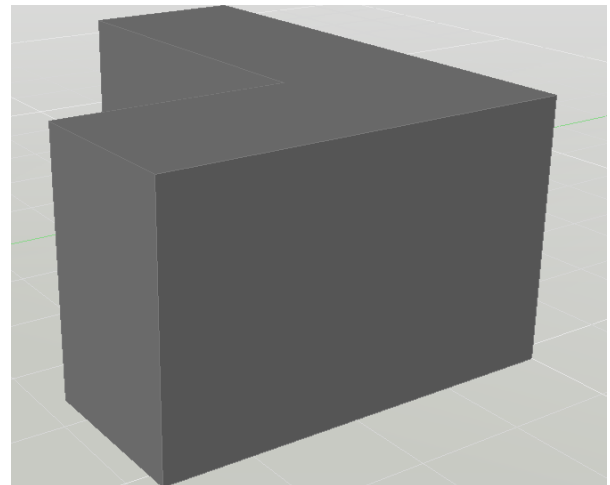
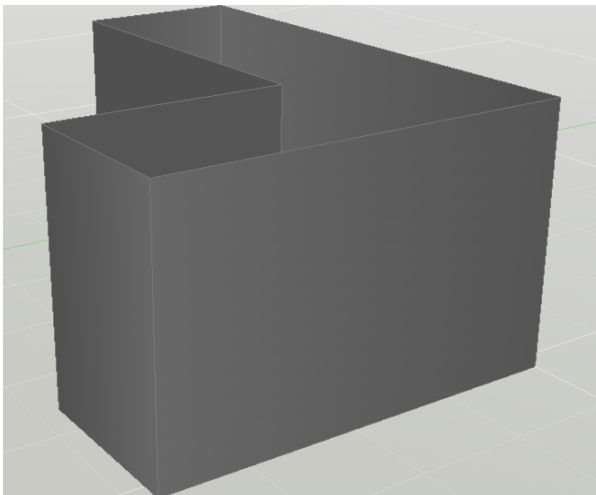

AutoCAD 3D Tutorial

13.2 Convert to Surface

Converts polylines and circles with thickness to surfaces.

1. Open a drawing with 2D polylines or circles with thicknesses and display in a 3D view.
2. Choose **Modify, 3D Operation, Convert to Surface**.
or
3. Type CONVTSURFACE at the command prompt.

Command: **convtosurface**

Select objects: 1 found

Select objects:

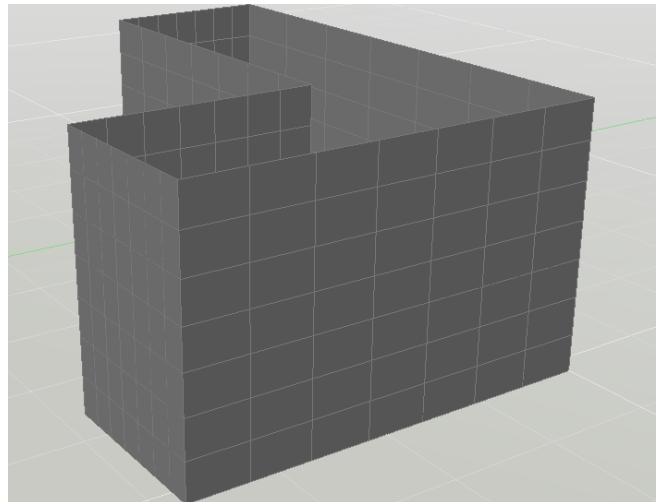
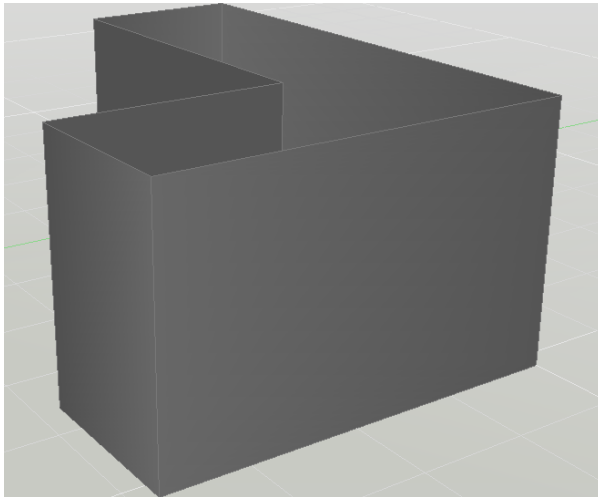

AutoCAD 3D Tutorial

13.3 3D Move

Displays the move grip tool in a 3D view and moves objects a specified distance.

1. Open a drawing with 3D objects and display in a 3D view.
2. Choose **Modify, 3D Operations, 3DMove**.

or

3. Type 3DMOVE at the command prompt.

Command: **3Dmove**

Select objects: **pick object to move**

1 found

Select objects: enter

Specify base point or [Displacement] <Displacement>: **D**

Specify displacement <0.0000, 0.0000, 0.0000>: **0,0,2**

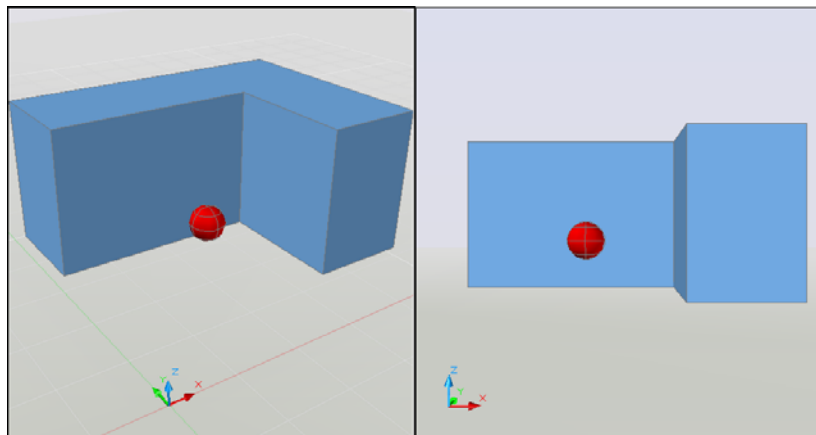
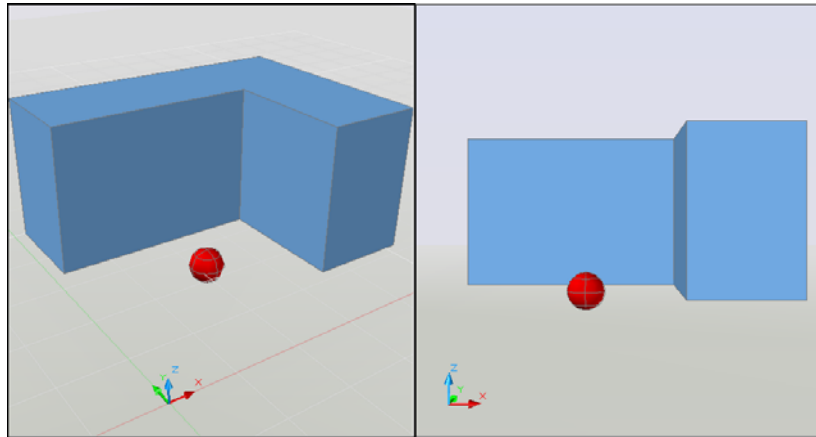

AutoCAD 3D Tutorial

13.4 3D Rotate

1. Open a drawing with 3D objects and display in a 3D view.
2. Choose **Modify, 3D Operations, 3DRotate**.

or

3. Type 3DROTATE at the command prompt.

Command: **3DROTATE**

Current positive angle in UCS: ANGDIR=counterclockwise
ANGBASE=0

Select objects: **pick object and press enter**

Specify base point: **pick point**

Pick a rotation axis: **select X axis**

Specify angle start point: **-90**

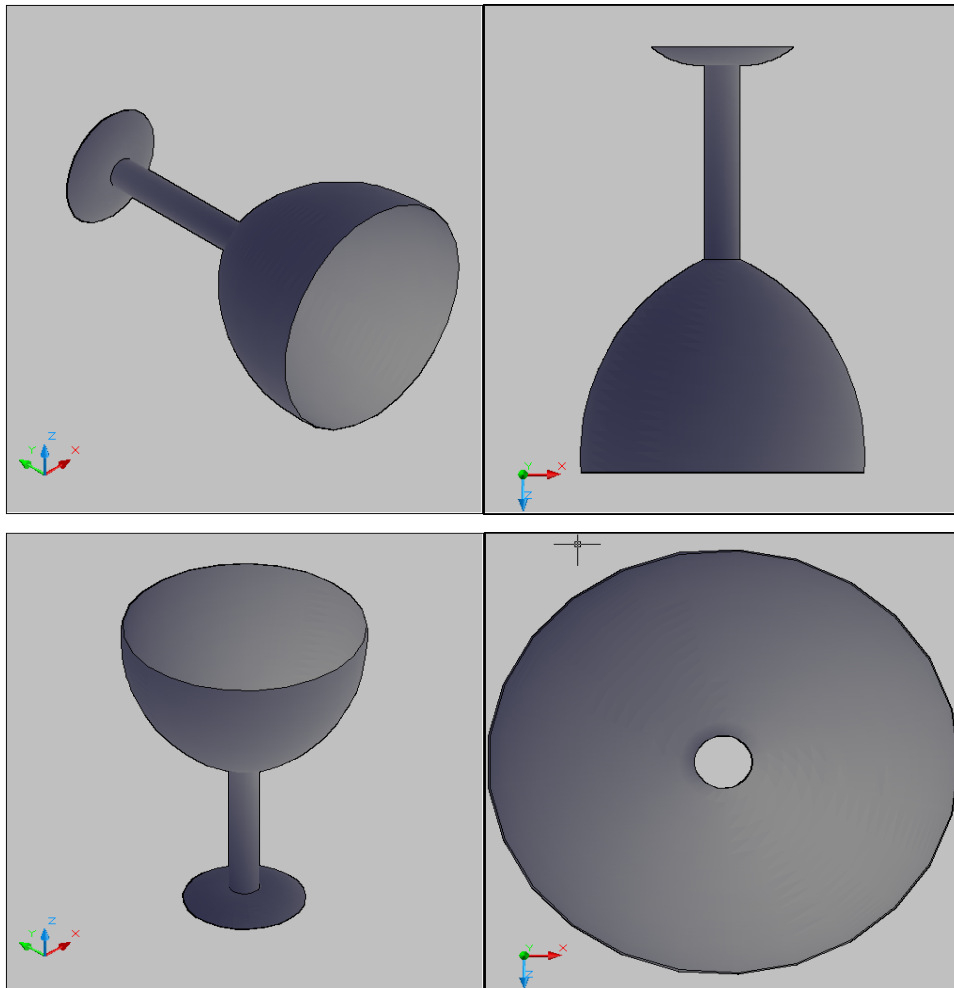

AutoCAD 3D Tutorial

13.5 3DAlign

1. Open a drawing with 3D objects and display in a 3D view.
2. Choose **Modify, 3D Operations, 3DAlign**.
or
3. Type 3DALIGN at the command prompt.

Command: **_3dalign**

Select objects: **pick and press enter**

Specify source plane and orientation ...

Specify base point or [Copy]:

Specify second point or [Continue] <C>:

Specify third point or [Continue] <C>:

Specify destination plane and orientation ...

Specify first destination point:

Specify second destination point or [eXit] <X>:

Specify third destination point or [eXit] <X>:

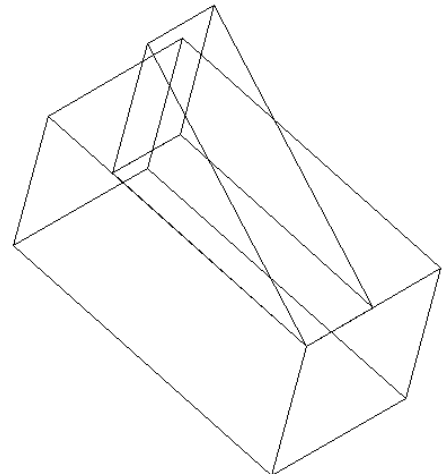
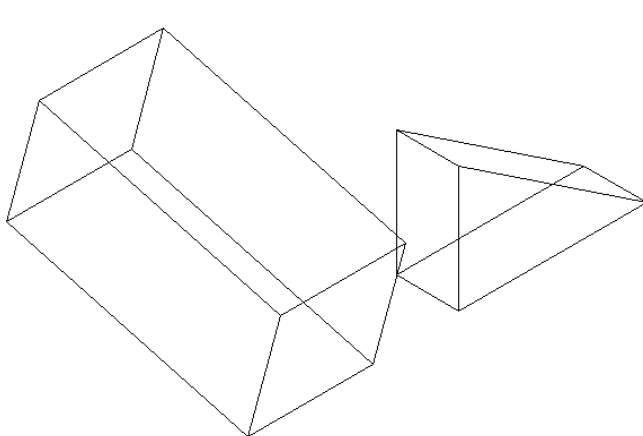

AutoCAD 3D Tutorial

13.6 3D Mirror

1. Open a drawing with 3D objects and display in a 3D view.
2. Choose **Modify, 3D Operations, 3DMirror**.
or
3. Type MIRROR3D at the command prompt.
Command: **mirror3D**
Select objects: **pick the circle**
Select objects: **enter**
Specify first point of mirror plane (3 points) or
[Object/Last/Zaxis/View/XY/YZ/ZX/3points] <3points>: **P1**
Specify second point on mirror plane: **P2**
Specify third point on mirror plane: **P3**
Delete source objects? [Yes/No] <N>: **enter**

Circle Mirrored around 3 Points

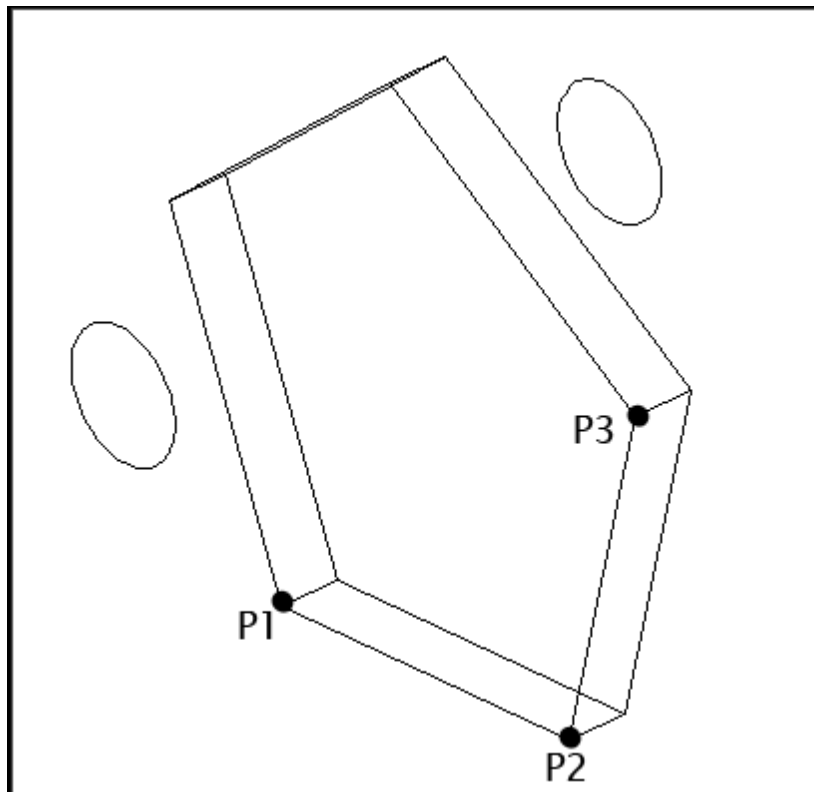

AutoCAD 3D Tutorial

13.7 3D Rectangular Array

1. Open a drawing with 3D objects and display in a 3D view.
2. Choose **Modify, 3D Operations, 3DArray**.
or
3. Type 3DARRAY at the command prompt.

Command: **3darray**

Select objects: pick object and press enter

Enter the type of array [Rectangular/Polar] <R>: **R**

Enter the number of rows (---) <1>: **3**

Enter the number of columns (|||) <1>: **4**

Enter the number of levels (...) <1>: **2**

Specify the distance between rows (---): **5**

Specify the distance between columns (|||): **4**

Specify the distance between levels (...): **8**

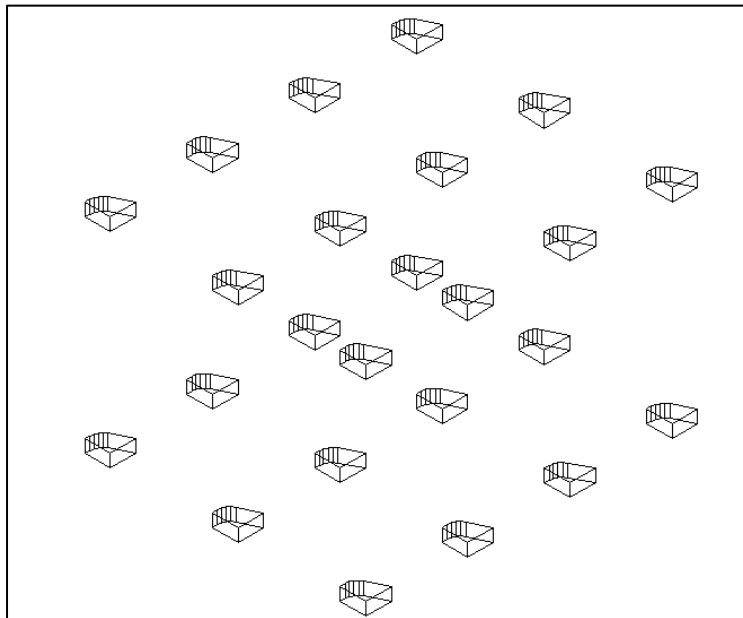

AutoCAD 3D Tutorial

13.8 3D Polar Array

1. Open a drawing with 3D objects and display in a 3D view.
2. Choose **Modify, 3D Operations, 3DArray**.
or
3. Type 3DARRAY at the command prompt.
Command: **3darray**
Select objects: **pick cube**
Select objects: **enter**
Enter the type of array [Rectangular/Polar] <R>: **P**
Enter the number of items in the array: **5**
Specify the angle to fill (+=ccw, -=cw) <360>: **enter**
Rotate arrayed objects? [Yes/No] <Y>: **enter**
Specify center point of array: **mid of axis line**
Specify second point on axis of rotation: **pick**

Arrayed Objects Around a Line

Arrayed Objects in Plan View

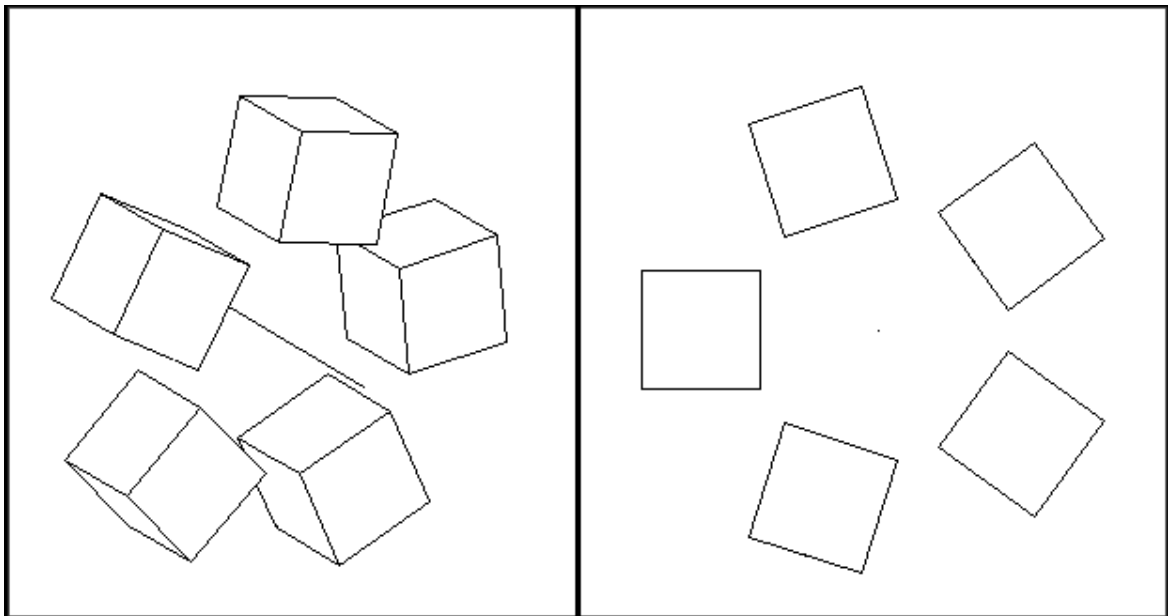

AutoCAD 3D Tutorial

13.9 Extract Edges

1. Open a drawing with 3D objects and display in a 3D view.
2. Choose **Modify, 3D Operations, Extract Edges**.
or
3. Type XEDGES at the command prompt.

Command: **_xedges**

Select objects: **pick object**

Select objects: **enter**

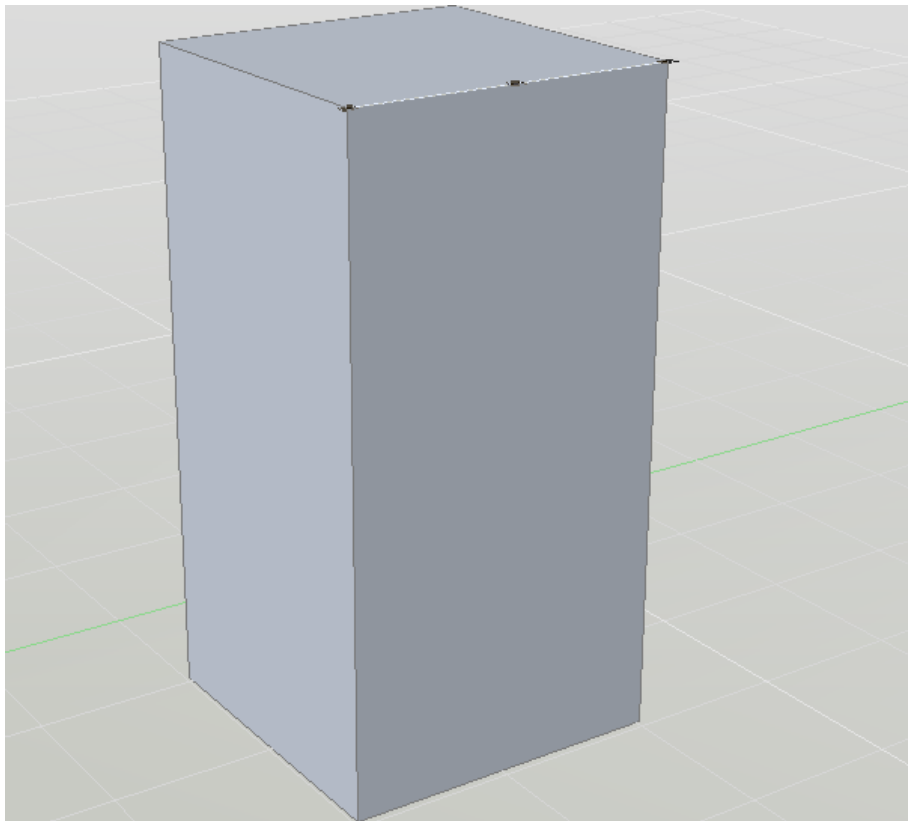

AutoCAD 3D Tutorial

13.10 Facetres

Adjusts the smoothness of shaded and rendered objects and objects with hidden lines removed. Valid values are from 0.01 to 10.0.

1. Open a drawing with 3D objects and display in a 3D view.
2. Type FACETRES at the command prompt.

Command: **FACETRES**

Enter new value for FACETRES <0.5000>: **10**

Facetres=.1

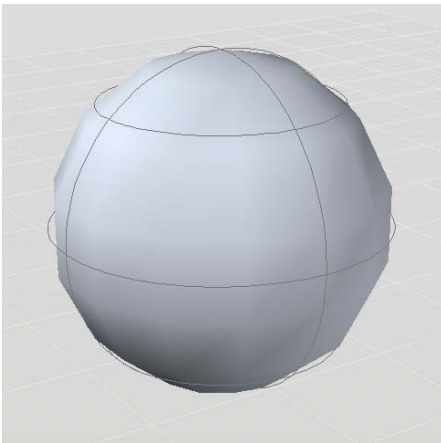

Facetres=10

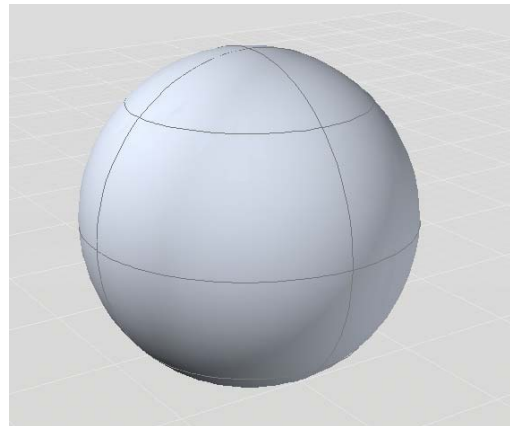

AutoCAD 3D Tutorial

13.11 Isolines

1. Open a drawing with 3D objects and display in a 3D view.
2. Type ISOLINES at the command prompt.

Command: **isolines**

Enter new value for ISOLINES <4>: **20**

Command: **regen**

REGEN Regenerating model.

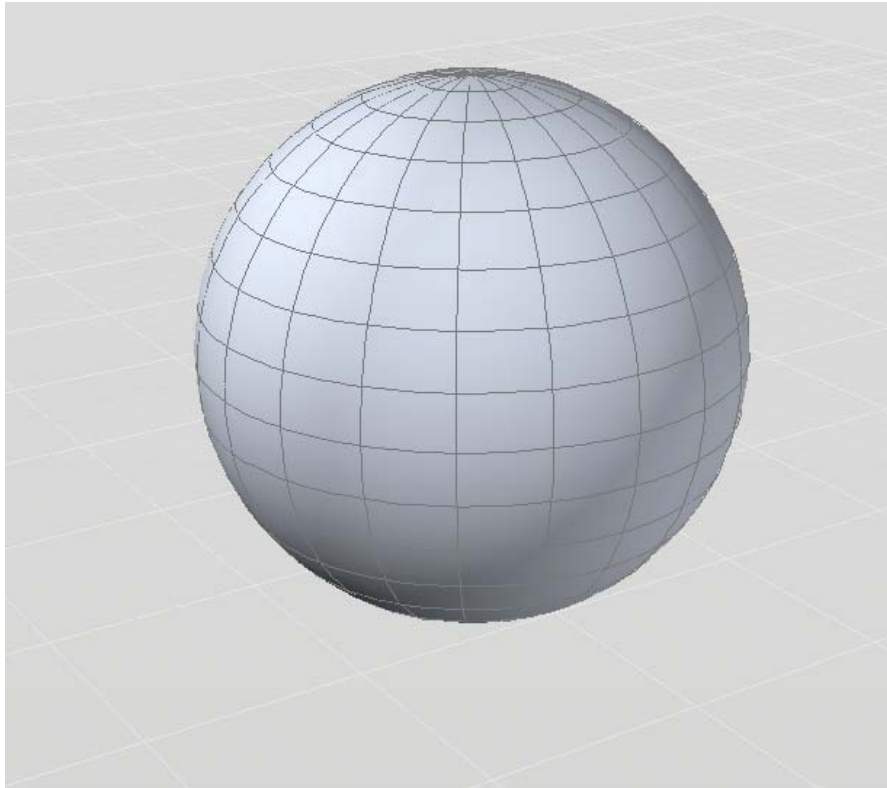

AutoCAD 3D Tutorial

13.12 Edge Effects

1. Open a drawing with 3D objects and display in a 3D view.
2. Choose one of the edge effects from the Edge Effects 3D ribbon panel.

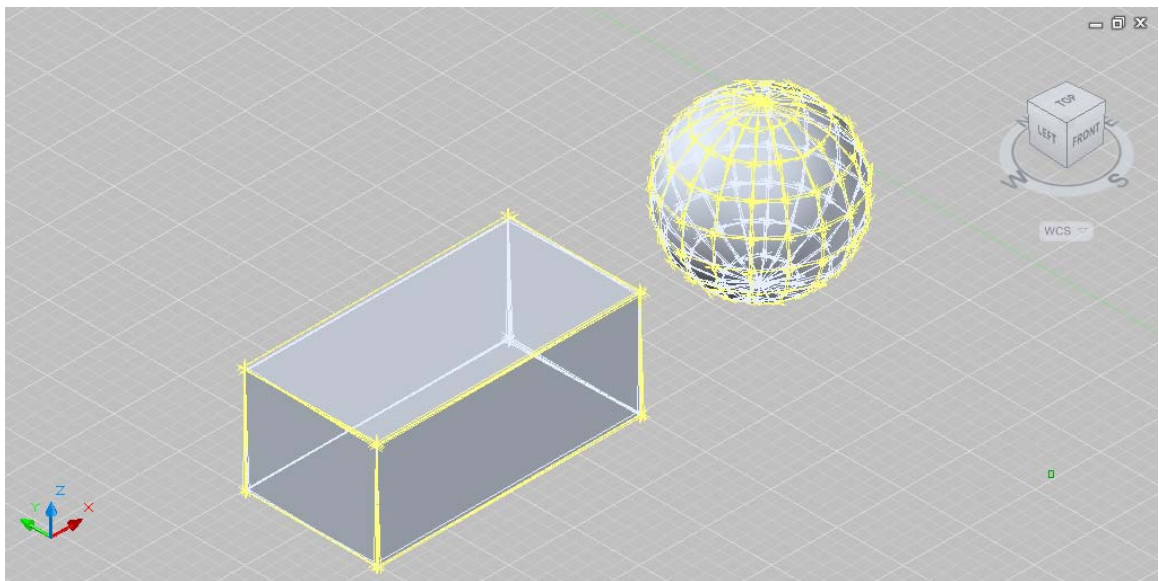
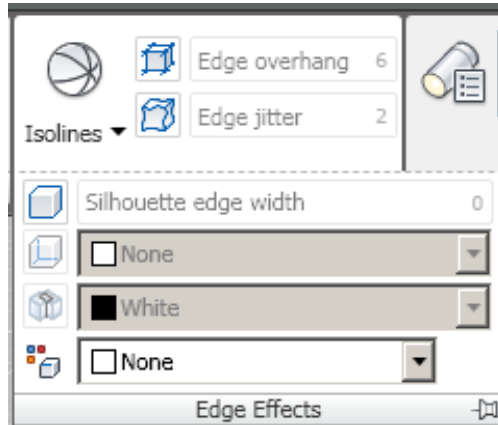

AutoCAD 3D – Chapter 14
Solid Composites

AutoCAD 3D Tutorial

14.1 Union

1. Open a drawing with 3D objects and display in a 3D view.
2. Choose **Modify, Solids Editing, Union**.
- or
3. Type UNION at the command prompt.

Command: **union**

Select objects: **pick objects to union**

Select objects: **enter**

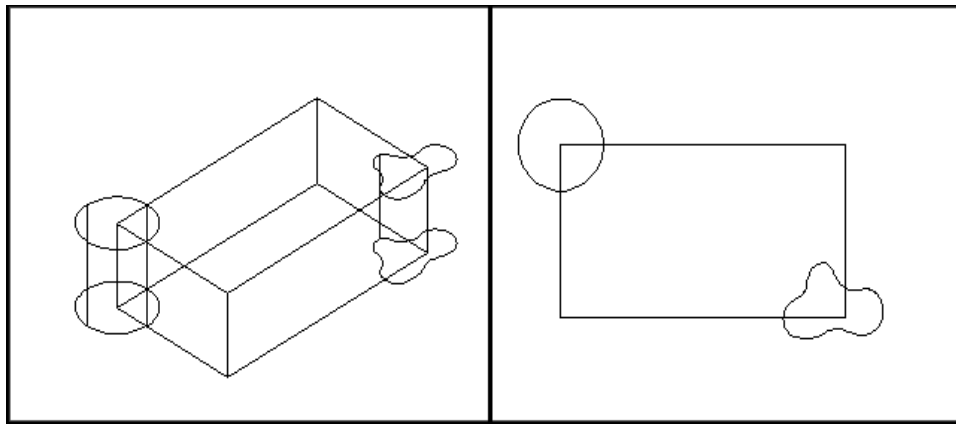

Solid Objects Unioned Together

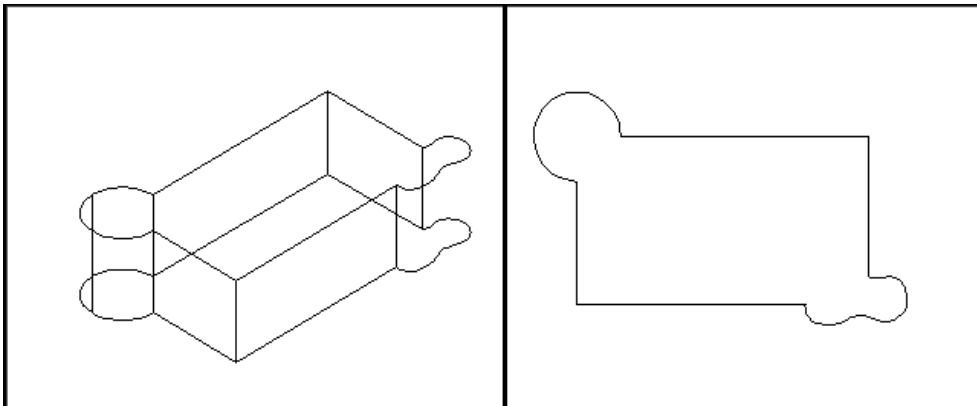

AutoCAD 3D Tutorial

14.2 Subtract

1. Open a drawing with 3D objects and display in a 3D view.
2. Choose **Modify, Solids Editing, Subtract**.
- or
3. Type SUBTRACT at the command prompt.

Command: **subtract**

SUBTRACT Select solids and regions to subtract from...

Select objects: **pick the box**

Select objects: **(press enter)**

Select solids and regions to subtract... Select objects: pick the cylinder
Select objects: enter

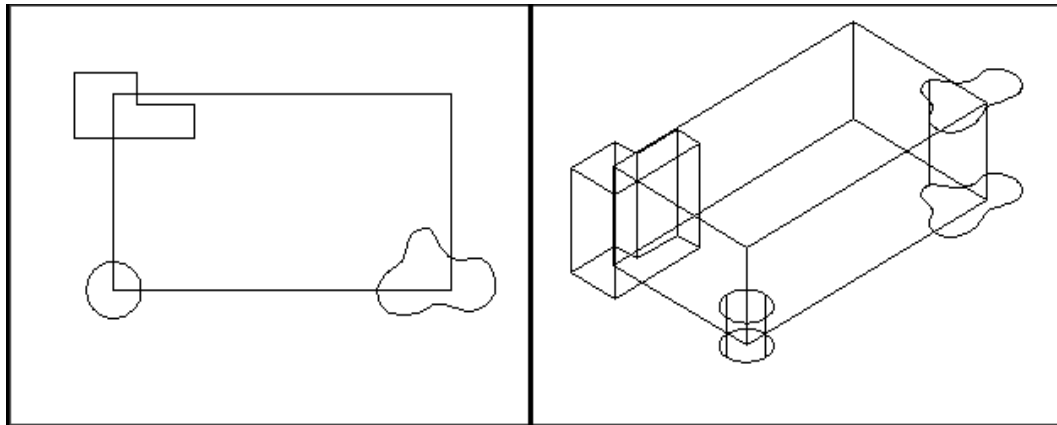

Objects Subtracted from Box

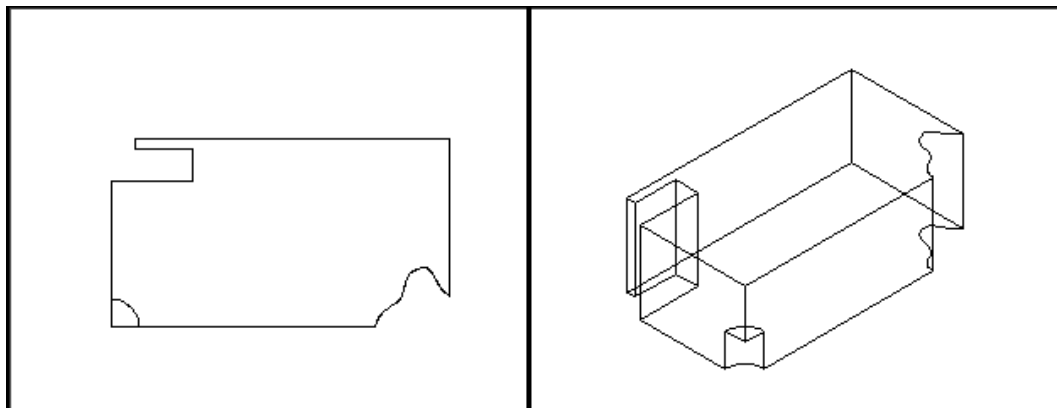

AutoCAD 3D Tutorial

14.3 Intersect

1. Choose **Modify, Solids Editing, Intersect**

or

2. Type INTERSECT at the command prompt.

Command: **intersect**

Select objects: **pick objects**

Select objects: **enter**

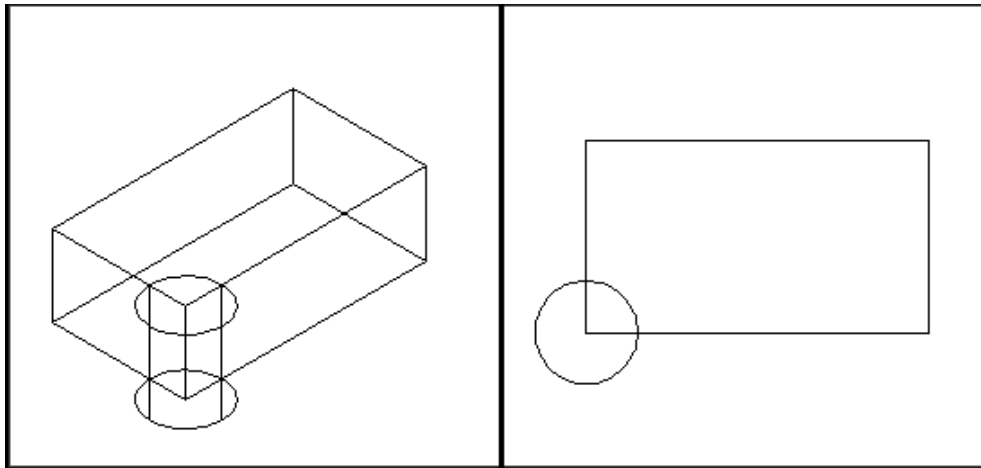

Intersection of Cylinder and Box

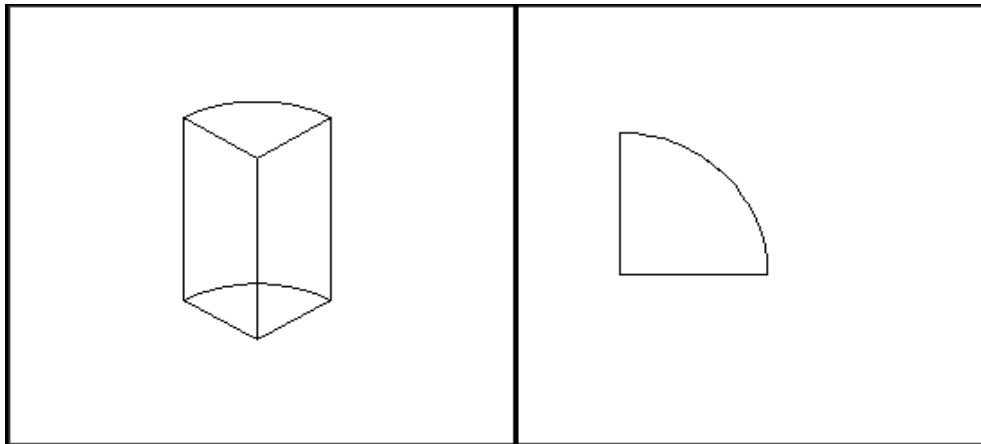

AutoCAD 3D Tutorial

14.4 Thicken

Creates a 3D solid by thickening a surface.

1. Open a drawing with 3D surface and display in a 3D view.
2. Choose **Modify, 3D Operation, Thicken**.

or

3. Type THICKEN at the command prompt.

Command: **thicken**

Select surfaces to thicken: 1 found

Select surfaces to thicken:

Specify thickness <0.0000>: 1

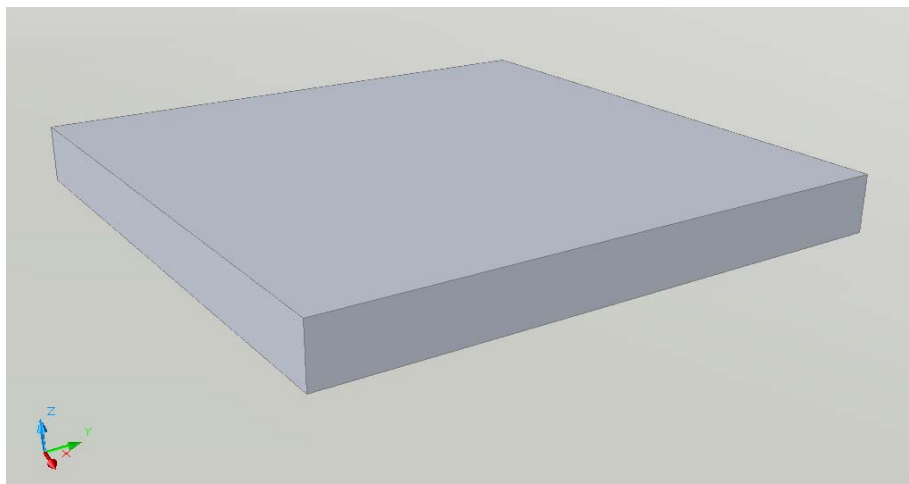
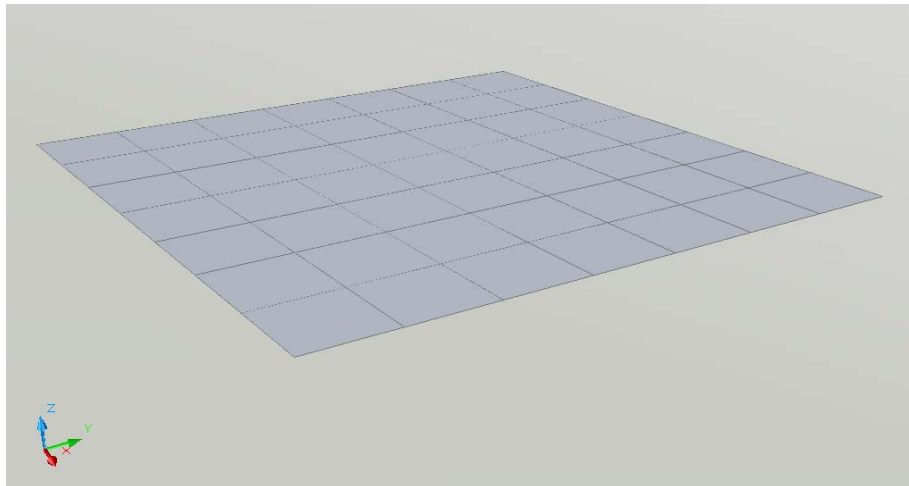

AutoCAD 3D Tutorial

14.5 Interference Checking

Highlights 3D solids that overlap.

1. Open a drawing with 3D objects that overlap and display in a 3D view.
2. Choose **Modify, 3D Operations, Interference Checking**.
or
3. Type INTERFERE at the command prompt.

Command: **interfere**

Select first set of objects or [Nested selection/Settings]: **pick objects and press enter.**

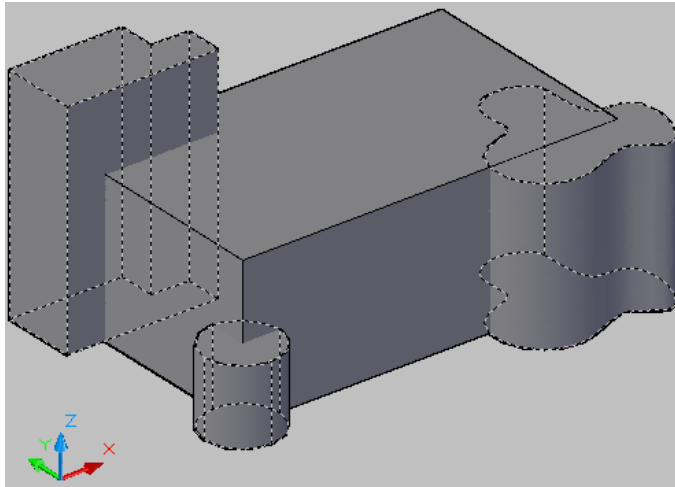

Select second set of objects or [Nested selection/check first set] <check>: **pick rectangle and press enter**

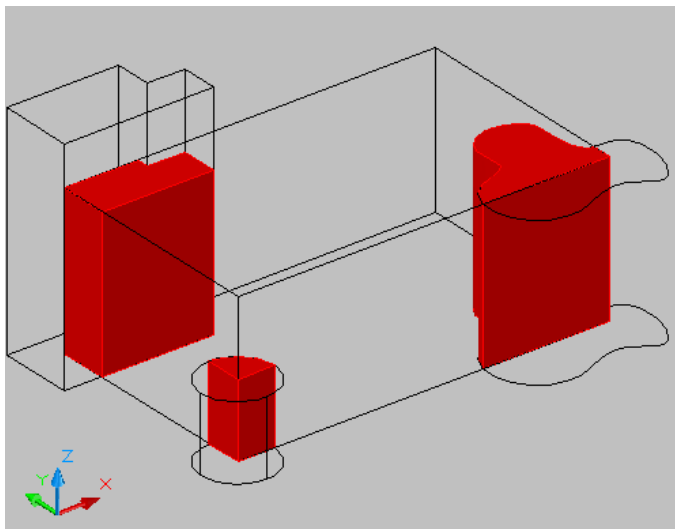

AutoCAD 3D Tutorial

The following dialog box allows you to change the zoom and display of the drawing to better see the interfering objects.

You can also choose to retain the interference objects by turning the check box off for “Delete interference objects created on Close”

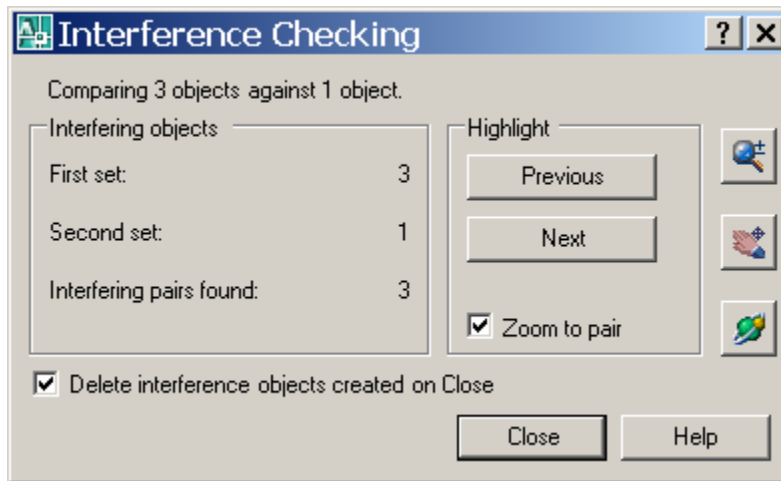

AutoCAD 3D – Chapter 15
Modifying Solid Faces

AutoCAD 3D Tutorial

15.1 Extrude Face

1. Choose **Modify, Solid Editing, Extrude face**.
NOTE: Must be a solid to extrude the face.
2. Choose a face to extrude. If you choose more than one face, hold the SHIFT key to deselect unwanted faces.
3. **Press ENTER.**
4. Specify height of extrusion or [Path]: **.25**
5. Specify angle of taper for extrusion <0>: **45**

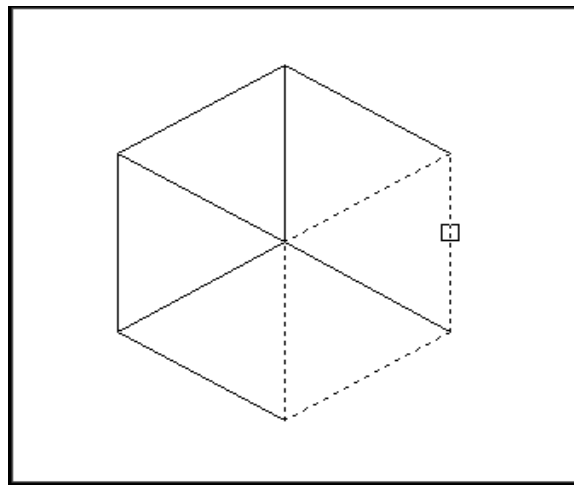

Select Face

Extruded Face

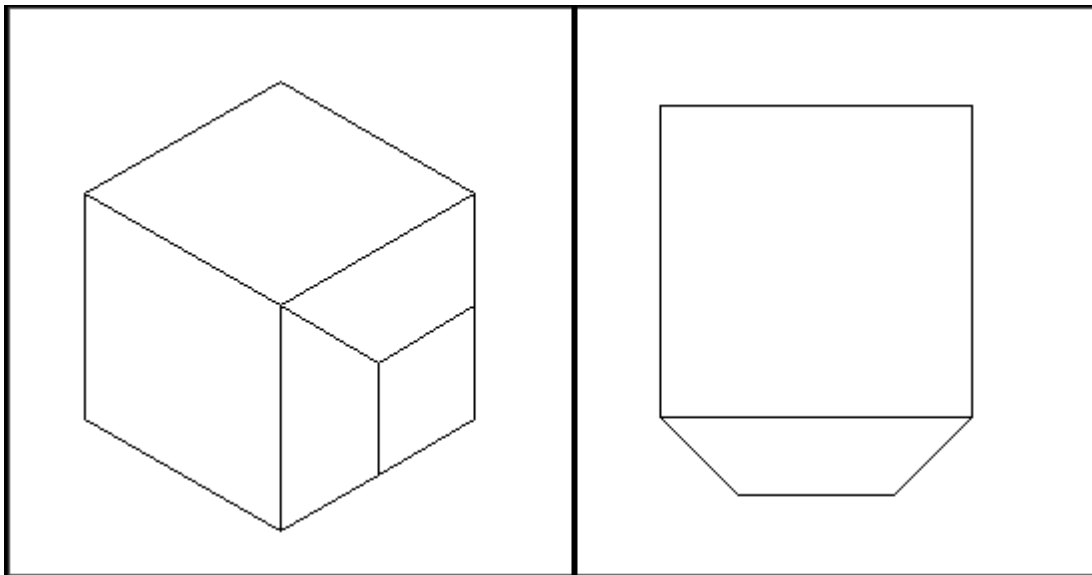

AutoCAD 3D Tutorial

15.2 Taper Face

1. Choose **Modify, Solid Editing, Taper face**.
2. Choose a face(s) to taper. If you choose more than one face, hold the SHIFT key to deselect unwanted faces.
3. **Press ENTER.**
4. Specify the base point: **pick the back left corner**
5. Specify another point along the axis of tapering: **pick point**
6. Specify the taper angle: **45**
Solid validation started. Solid validation completed.

Before Taper

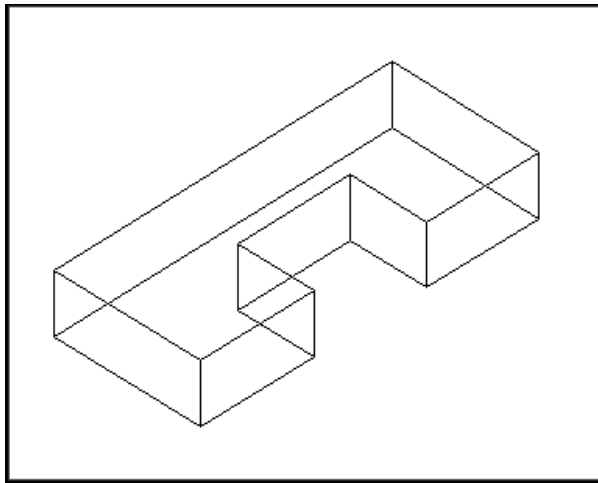

After Taper

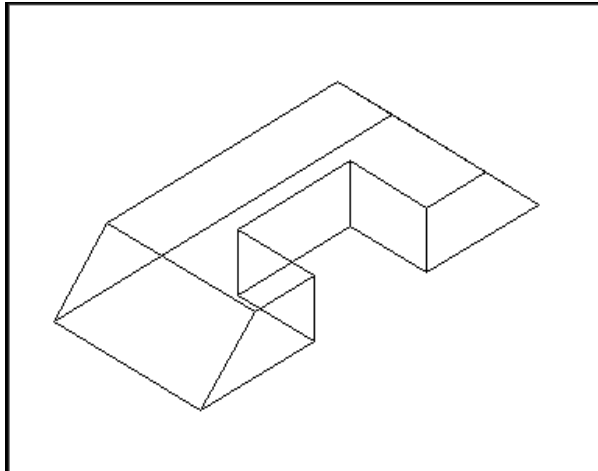

AutoCAD 3D Tutorial

15.3 Delete Face

1. Choose **Modify, Solid Editing, Delete face**.
2. Choose a face to delete. If you choose more than one face, hold the SHIFT key to deselect unwanted faces.
3. **Press ENTER.**
4. Choose the face to delete.

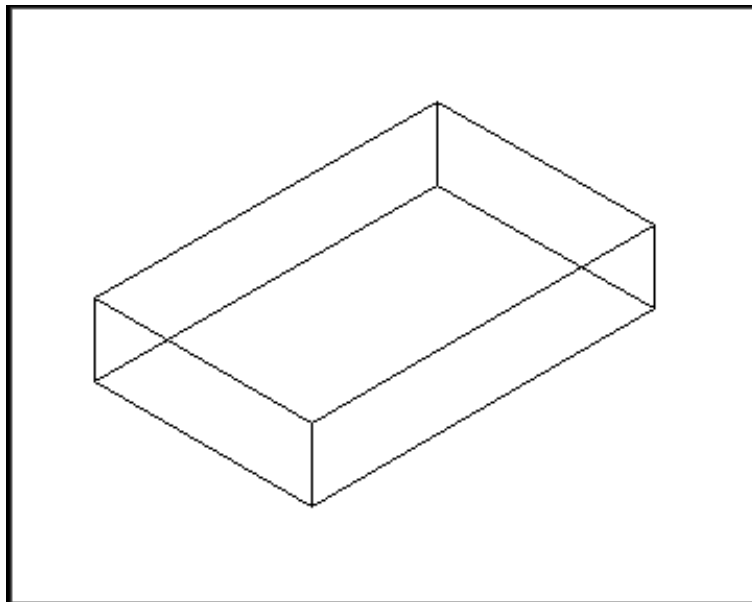
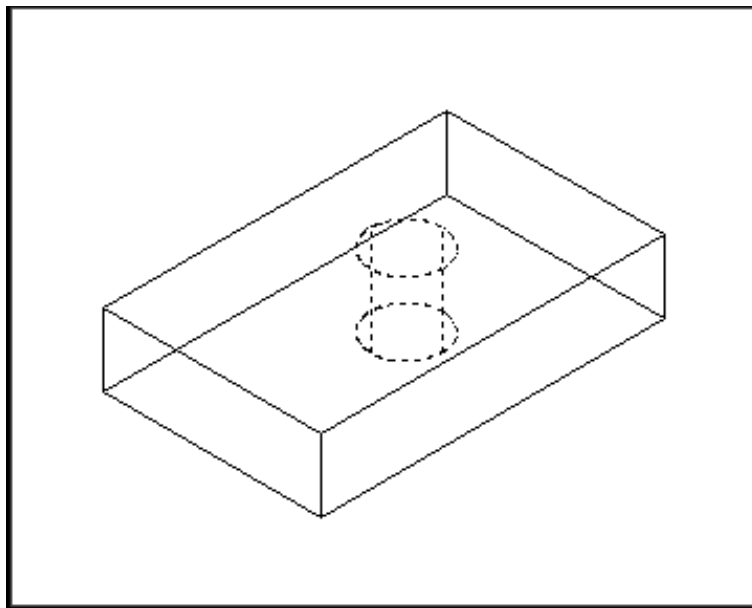

AutoCAD 3D Tutorial

15.4 Copy Face

1. Choose **Modify, Solid Editing, Copy face**.
2. Choose a face to copy . If you choose more than one face, hold the SHIFT key to deselect unwanted faces.
3. **Press ENTER.**
4. Pick the solid face to copy.
5. Pick a new location.

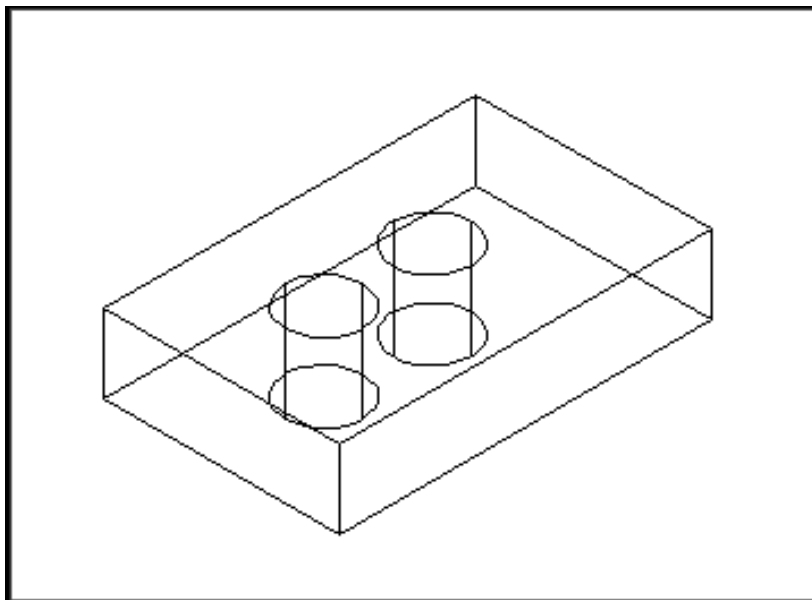
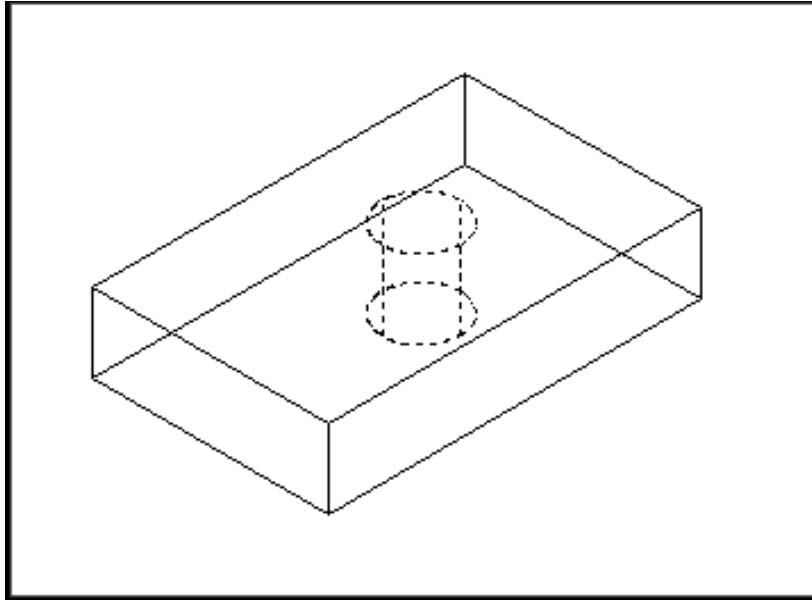

AutoCAD 3D Tutorial

15.5 Color Face

1. Choose **Modify, Solid Editing, Color face**.
2. Choose a face to change the color of. If you choose more than one face, hold the SHIFT key to deselect unwanted faces.
3. **Press ENTER.**
4. Choose a color to change the face to.

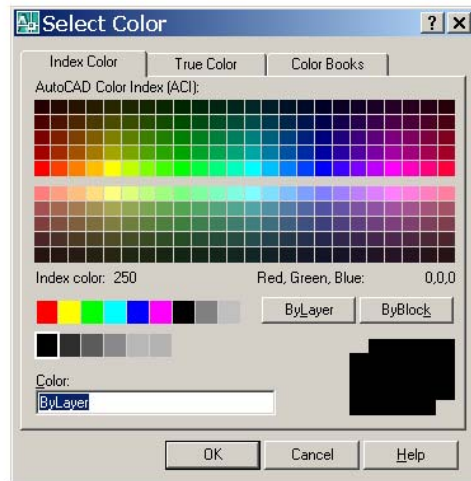
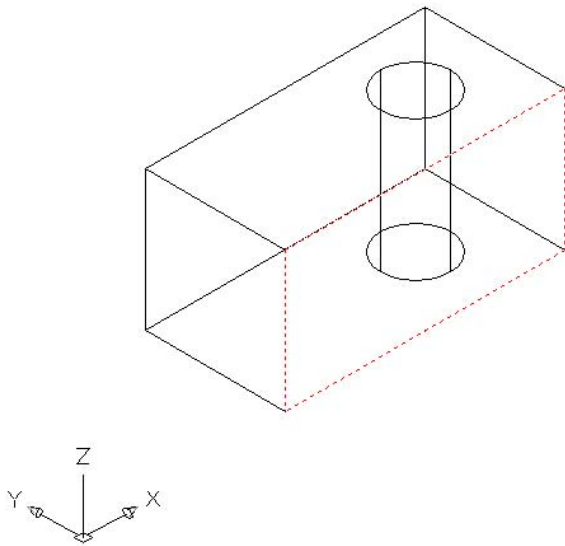

AutoCAD 3D Tutorial

15.6 Imprint

Imprints an object on the selected solid. The object to be imprinted must intersect one or more faces on the selected solid in order for imprinting to be successful. Imprinting is limited to the following objects: arcs, circles, lines, 2D and 3D polylines, ellipses, splines, regions, bodies, and 3D solids

1. Extrude objects (i.e. walls) to create a solid object.
2. Change the UCS and draw an object on a face of one of the walls.
3. Choose **Modify, Solid Editing, Imprint**.
4. Select a 3D solid: **pick solid**
5. Select an object to imprint: **pick circle**
6. Delete the source object <N>: **Y**

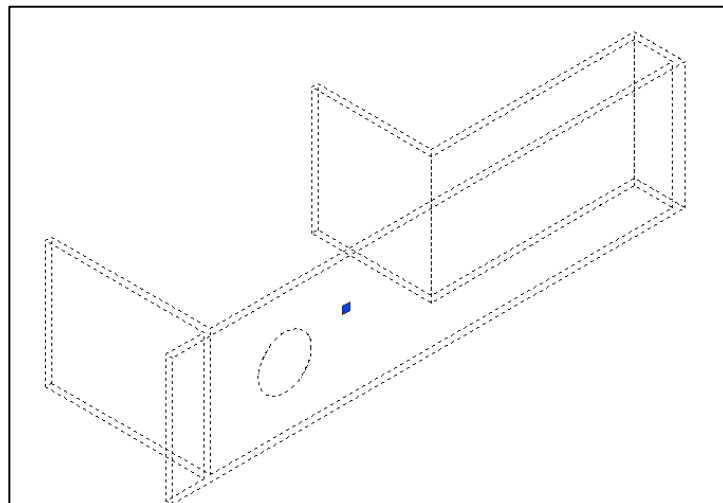
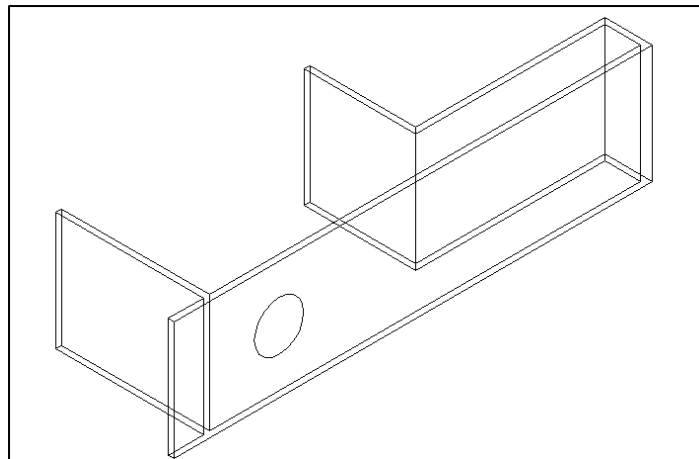

AutoCAD 3D Tutorial

15.7 Extrude Imprint

1. Choose **Modify, Solid Editing, Extrude Faces**.
2. Select the circle that was imprinted in 15.6.
3. Deselect any unwanted faces.
4. **Type -8** as the height of extrusion (or desired height).

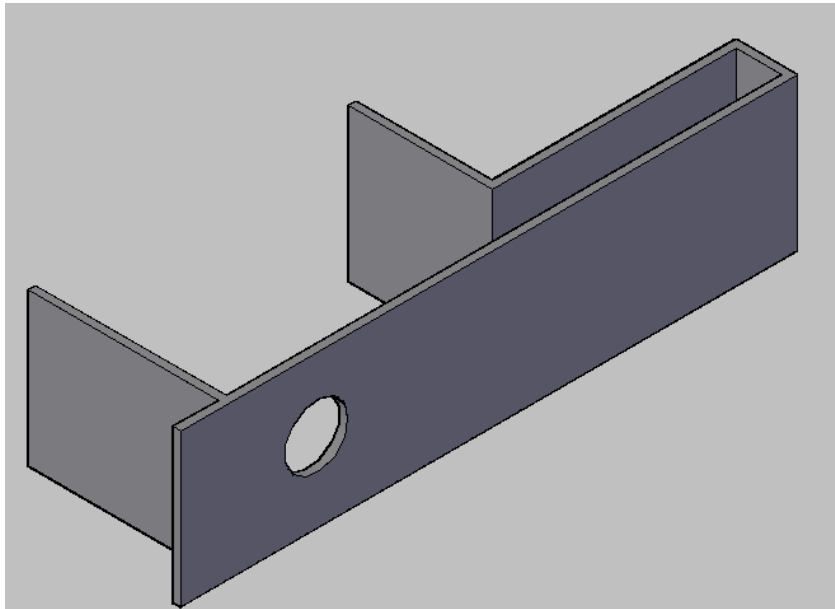

AutoCAD 3D Tutorial

15.9 Shell

You can create a shell or a hollow thin wall with a specified thickness from your 3D solid object. AutoCAD creates new faces by offsetting existing ones inside or outside their original positions. AutoCAD treats continuously tangent faces as single faces when offsetting.

1. Choose **Modify, Solid Editing, Shell**.
2. Select a 3D solid: **pick solid**
Remove faces or [Undo/Add/ALL]: **enter**
Enter the shell offset distance: **.5**

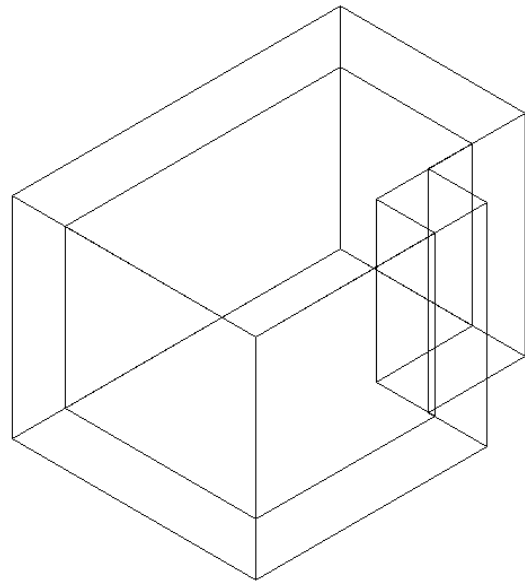
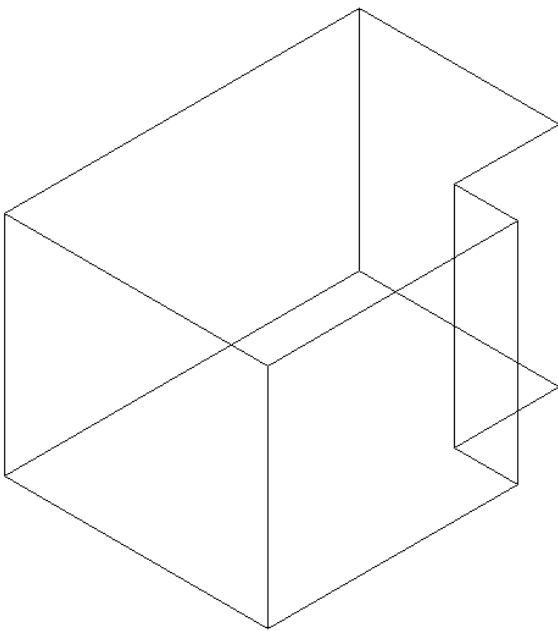

AutoCAD 3D – Chapter 16
Editing Solids

AutoCAD 3D Tutorial

16.1 Select and Manipulate Subobjects

You can select one subobject, or create a selection set of more than one subobject on any number of solids. Your selection set can also include more than one type of subobject.

1. Open a drawing with 3D solid object and display in a 3D view.
2. Hold the CTRL key and select the solid.
3. While holding CTRL, toggle to other subobjects within the solid.
4. Once selected, click and drag to modify the solid.

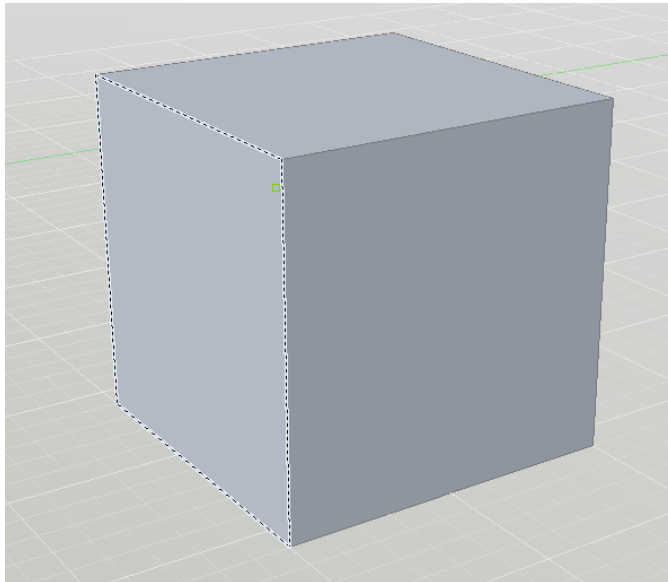

AutoCAD 3D Tutorial

16.2 Use Grip Tools

Grip tools are icons that you use in a 3D view to easily constrain the movement or rotation of a selection set of objects to an axis or a plane.

There are two types of grip tools:

- Move (3DMOVE command)
- Rotate (3DROTATE command)

1. Open a drawing with 3D solid object and display in a 3D view.
2. Hold the CTRL key and select the solid.
3. While holding CTRL, toggle to other subobjects within the solid.
4. Once selected, click and drag to modify the solid using the grip tool.

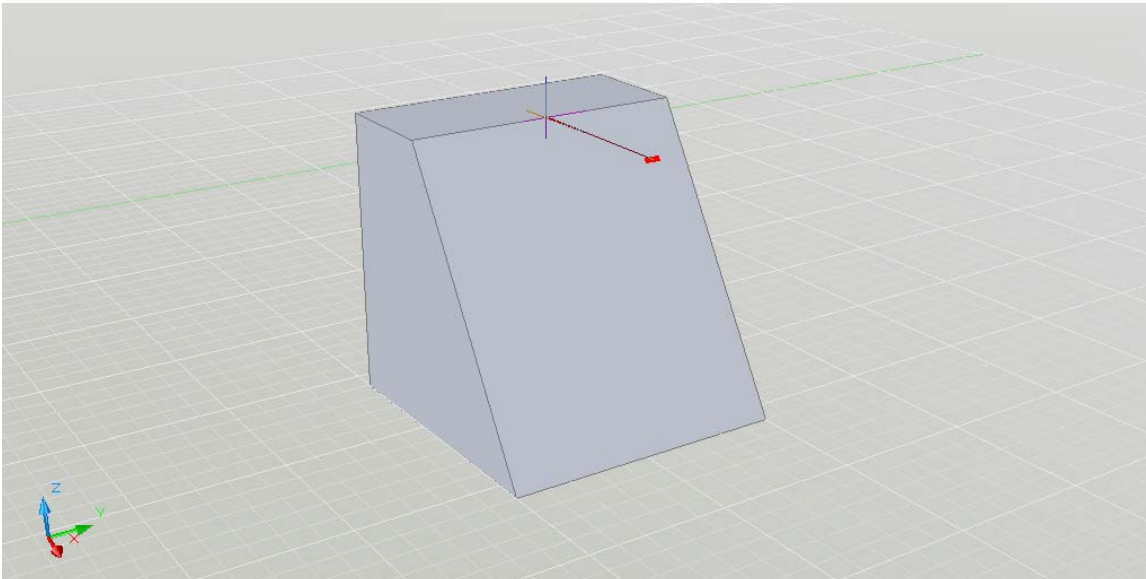

AutoCAD 3D Tutorial

16.3 Press or Pull Bounded Areas

You can press or pull bounded areas by pressing and holding CTRL + ALT, or by clicking the Presspull button on the dashboard and then picking the bounded area. The area must be bounded by coplanar lines or edges.

1. Open a drawing with a 3D object and imprinted object and display in a 3D view.
2. Hold the **CTRL** and **ALT** keys and select the imprinted object or solid face to manipulate it.
3. Click and drag to a new location.

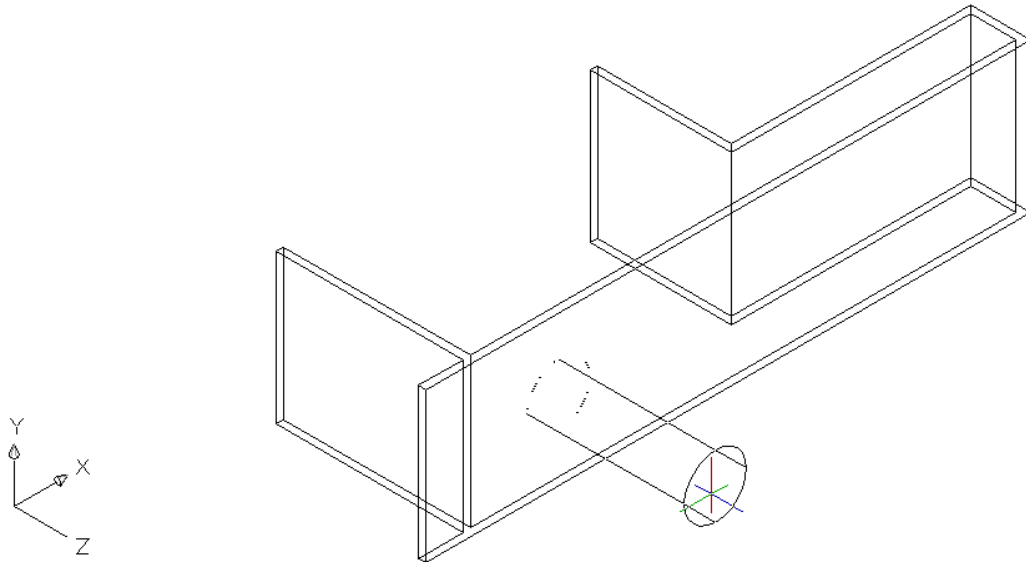

**AutoCAD 3D – Chapter 17
Sections and Flat Objects
from 3D Models**

AutoCAD 3D Tutorial

17.1 Sectionplane Command

The SECTIONPLANE command creates a section object that exposes the interior details of a model created with 3D objects.

Once you create a section object, you can move and manipulate it to fine-tune the sectional view you want.

1. Open a drawing with 3D solid objects and display in a plan and 3D view.
2. Choose **Draw, Modeling, Sectionplane**.
- or
3. Type SECTIONPLANE at the command prompt.

Command: **sectionplane**

Select face or any point to locate section line or [Draw section/Orthographic]: **O**

Align section to: [Front/bAck/Top/Bottom/Left/Right] <Front>: **enter**

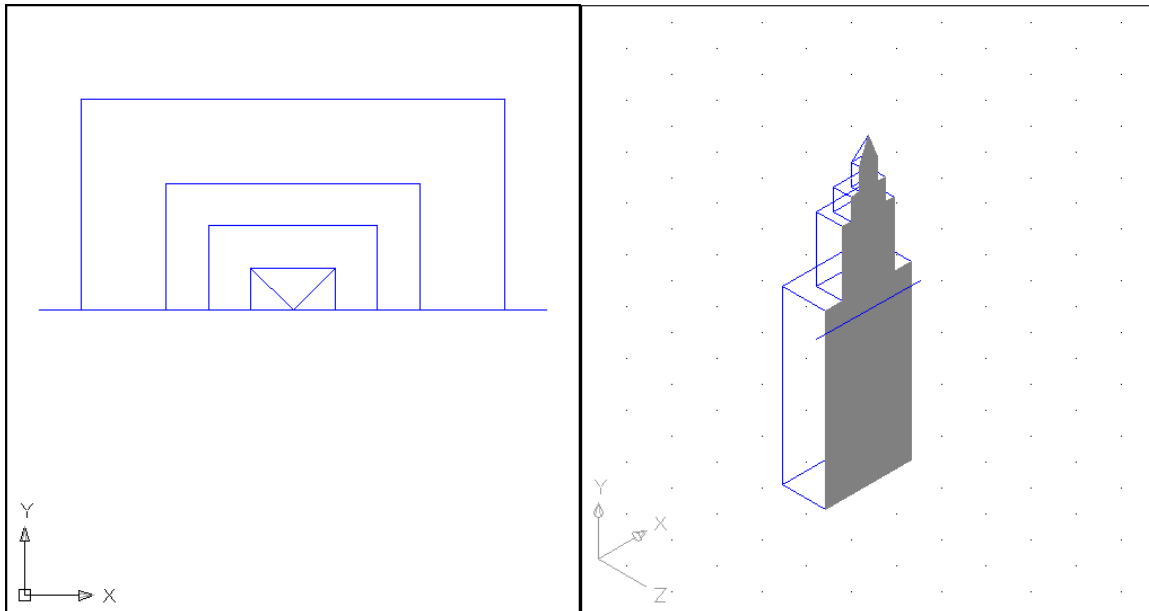

AutoCAD 3D Tutorial

17.2 Manipulate Section Using Grips

1. Click on a section line created using the SECTIONPLANE command.
2. Click on one of the grips to manipulate the section.

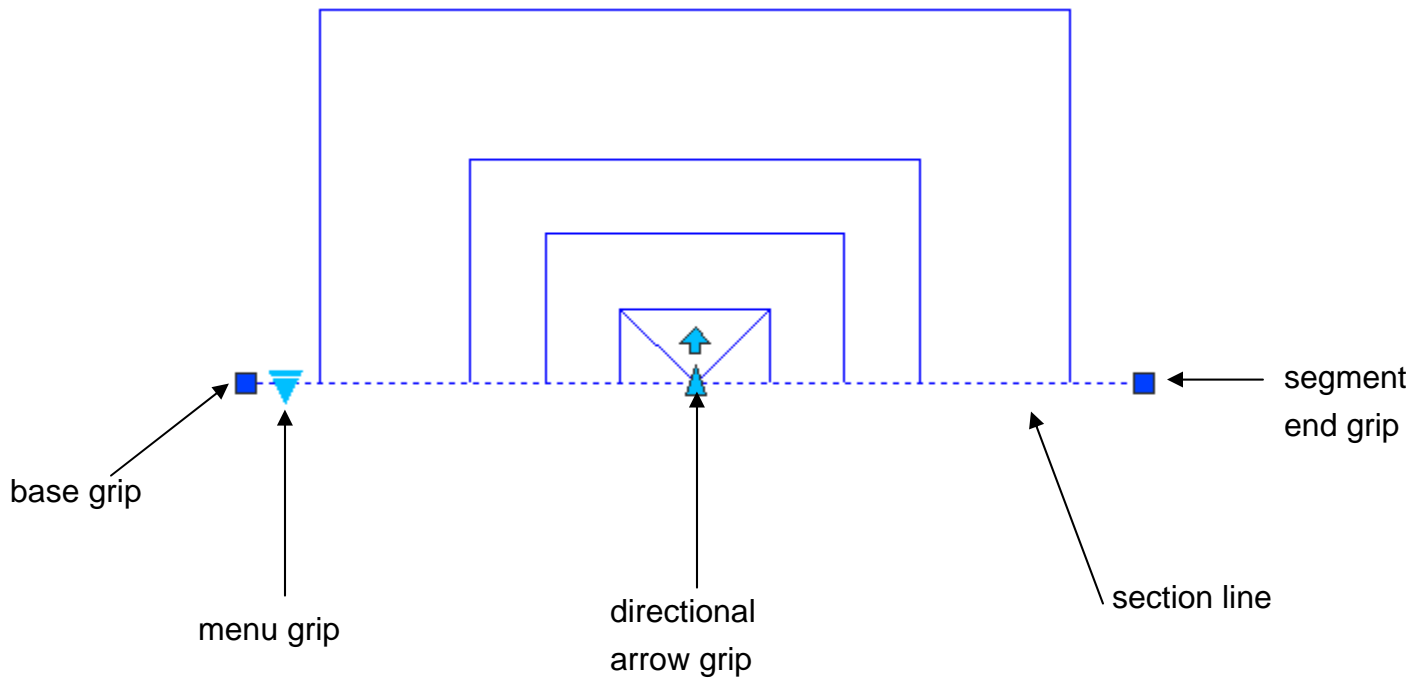

Base grip - moves the entire section object

Directional arrow grip – changes the cutting plane direction

Segment end grip - rotates the section object around the base grip

Menu grip - moves between the three states

AutoCAD 3D Tutorial

17.3 Section Shortcut Commands

1. Right-click on a section line to see the following section options.

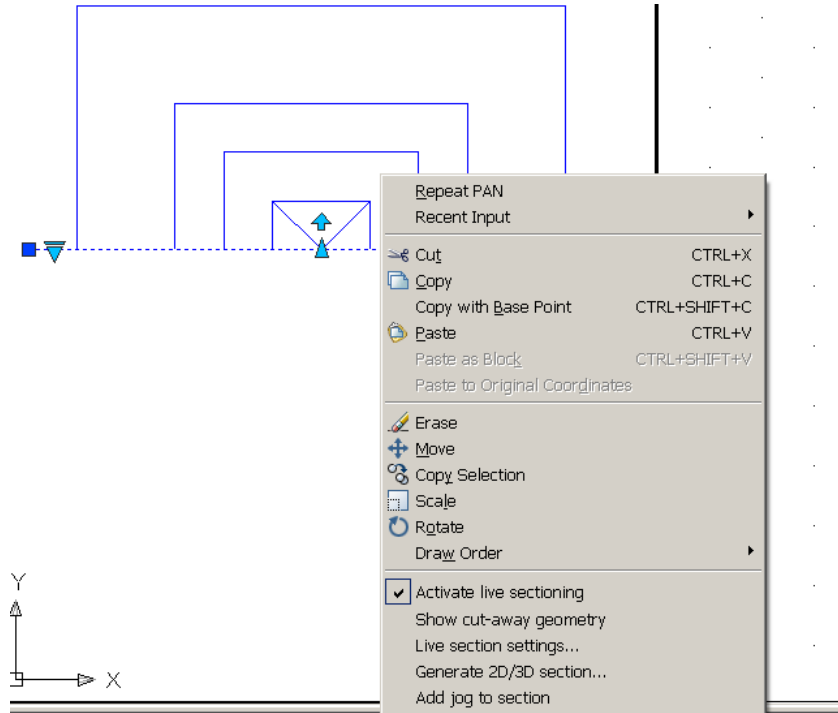

2. Click the various section options.

AutoCAD 3D Tutorial

17.4 Generate 2D and 3D Sections

1. **Right-click** on a section line.
2. Click **Generate 2D/3D section...**
3. From the following dialog box, click the down arrow to see all of the section options.

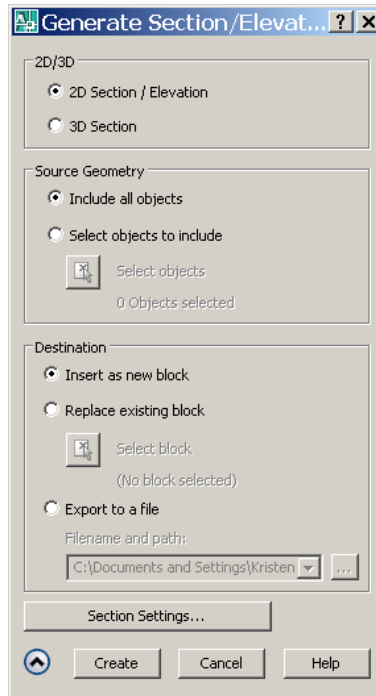

4. Choose **2D Section** and **Create**.
5. Click an insertion point and scale for the 2D section block.

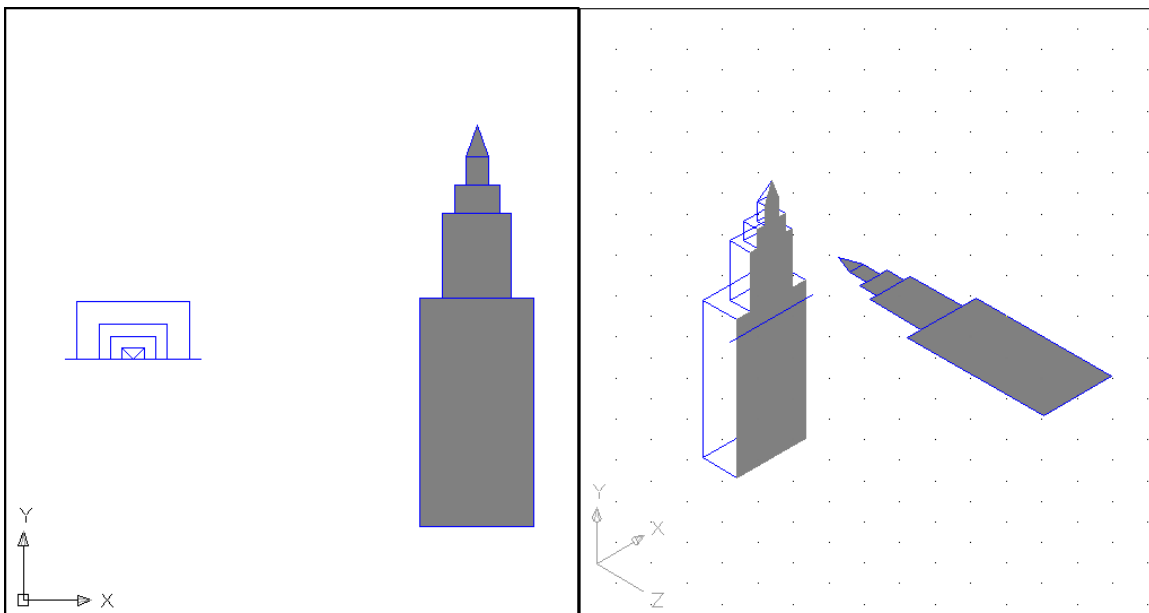

AutoCAD 3D Tutorial

17.5 Section Command

Uses the intersection of a plane and solids to create a region

1. Open a drawing with 3D objects and display in a 3D view.
2. Type SECTION at the command prompt.

Command: **section**

Select objects: **pick solid and press enter**

Specify first point on Section plane by
[Object/Zaxis/View/XY/YZ/ZX/3points] <3points>: **XY**

Specify a point on the XY-plane <0,0,0>: **MID of**

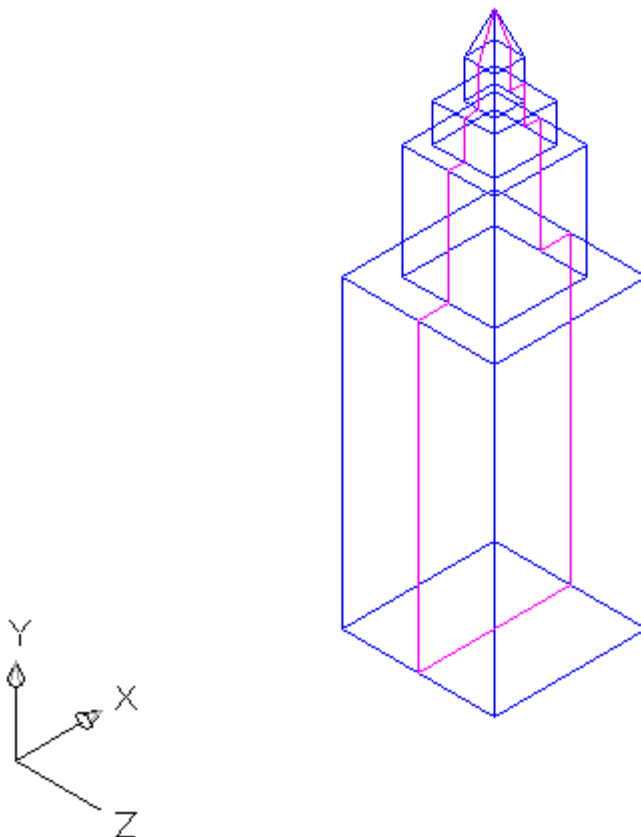

AutoCAD 3D Tutorial

17.6 Slice Command

1. Open a drawing with 3D objects and display in a 3D view.
2. Choose **Modify, 3D Operation, Slice**.

or

3. Type SLICE at the command prompt.

Command: **slice**

Select objects to slice: 1 found

Specify start point of slicing plane or [planar

Object/Surface/Zaxis/View/XY/YZ/ZX/3points] <3points>: **YZ**

Specify a point on the YZ-plane <0,0,0>: **MID of**

Specify a point on desired side or [keep Both sides] <Both>:

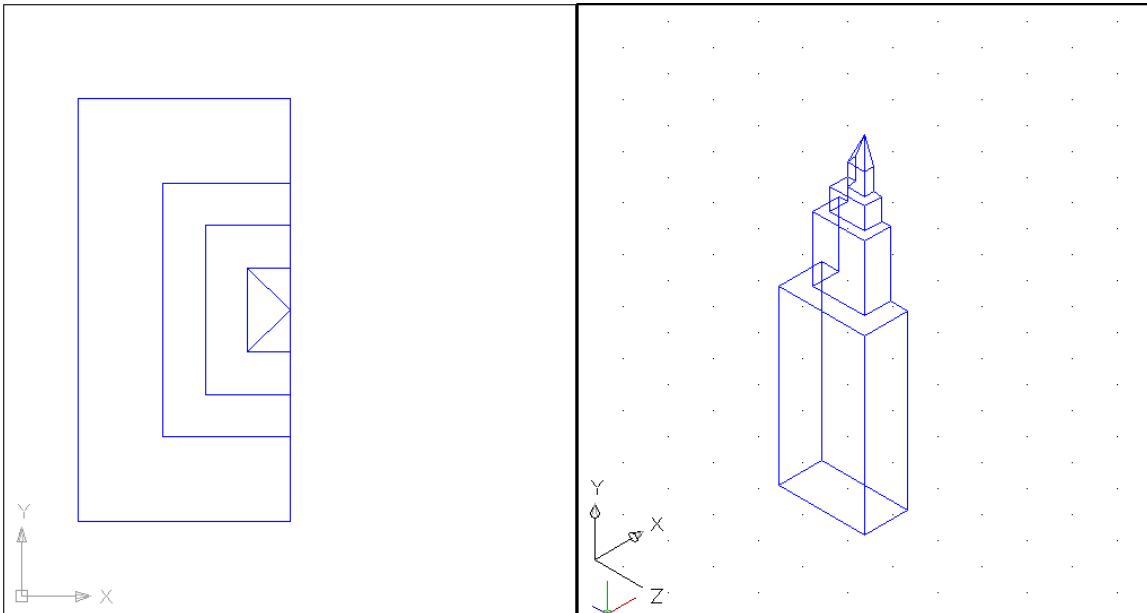

AutoCAD 3D Tutorial

17.7 Flatshot

Creates a 2D or “flattened” representation of all 3D objects in the current view.

1. Click the Solid Editing dropdown from the Solid Editing ribbon panel.

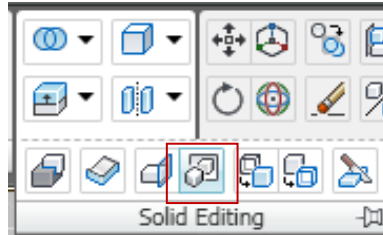

or

2. Type FLATSHOT at the command prompt.
Command: **flatshot**

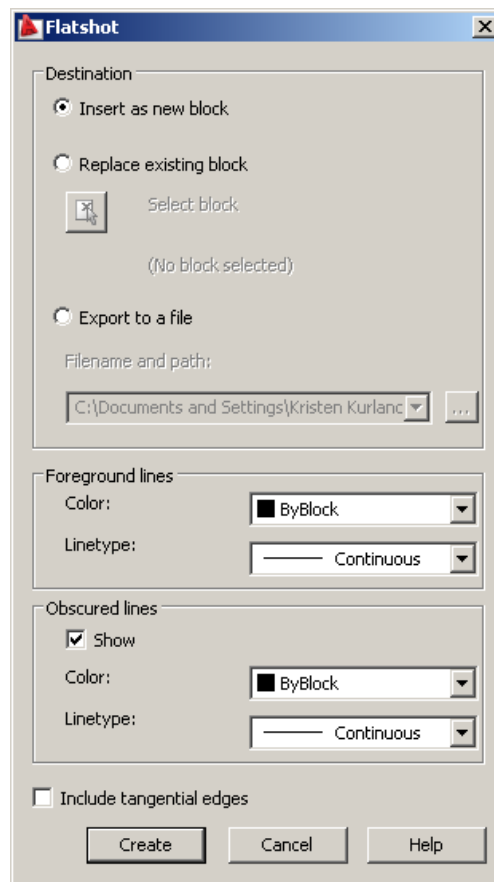

AutoCAD 3D Tutorial

2. Click Create and a location point for a block to insert.

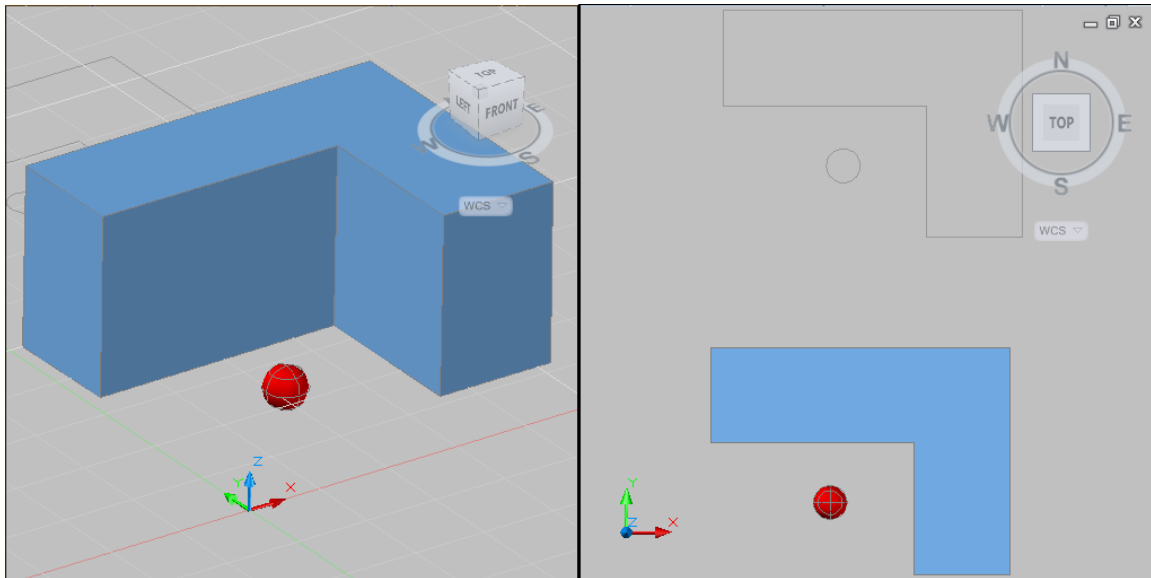

AutoCAD 3D Tutorial

17.8 Solview

1. Choose File, New...
2. Choose “Use a Template” from the startup dialog.
3. Double-click **acad.dwt** as the template file to start from.

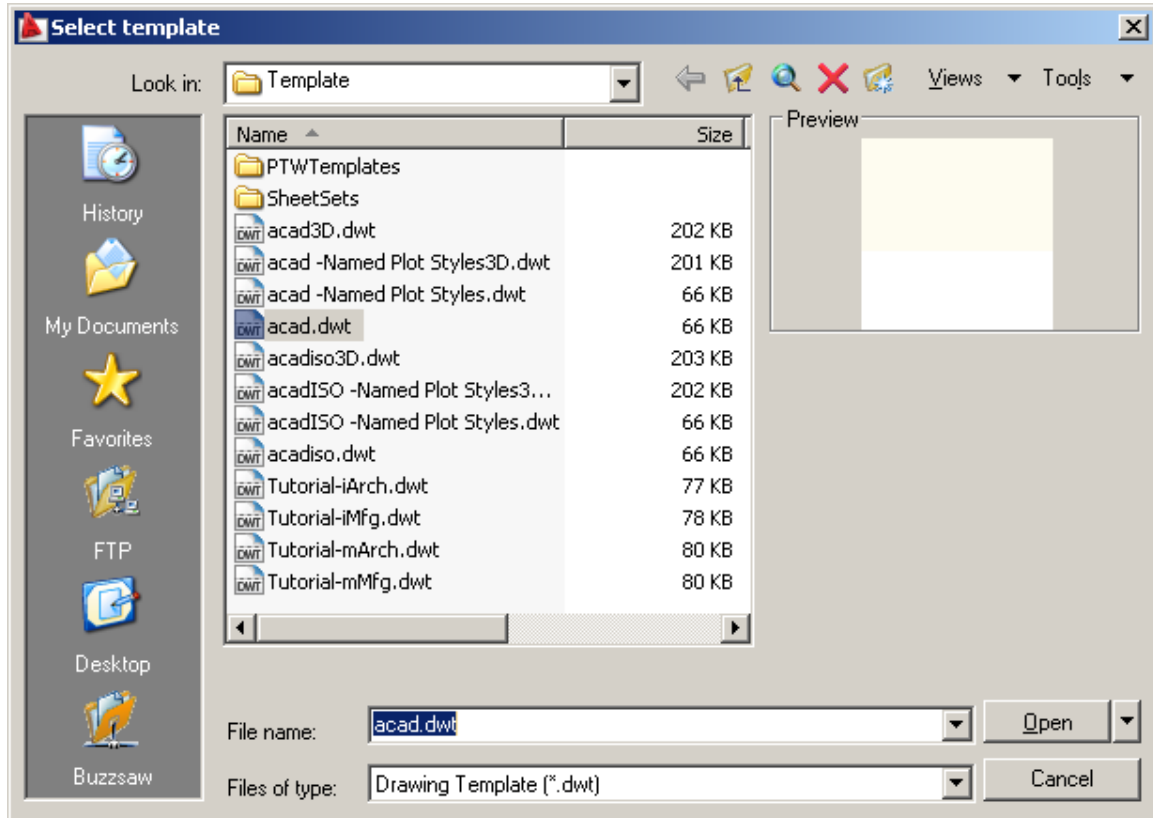

4. Create a new layout.
5. Move and resize the model view so it is in the upper left corner of the sheet as follows.

AutoCAD 3D Tutorial

Drawing with a Model Space View

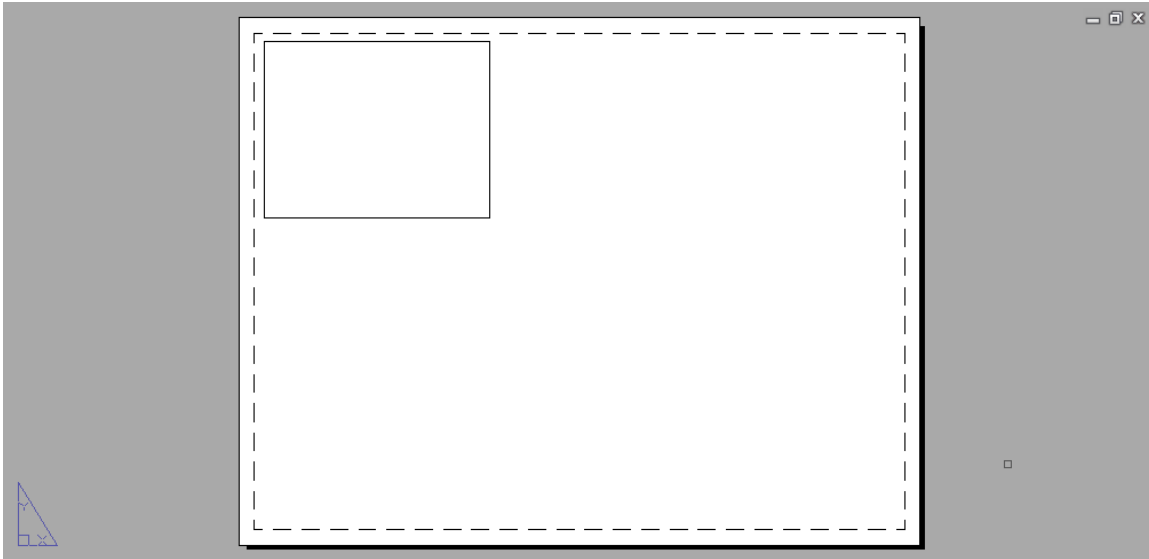

6. Type **MSPACE** at the command prompt.
7. Type **INSERT** at the command prompt and choose the drawing called **3DBOTTLE.DWG** to insert. Explode the Block as you are inserting it.

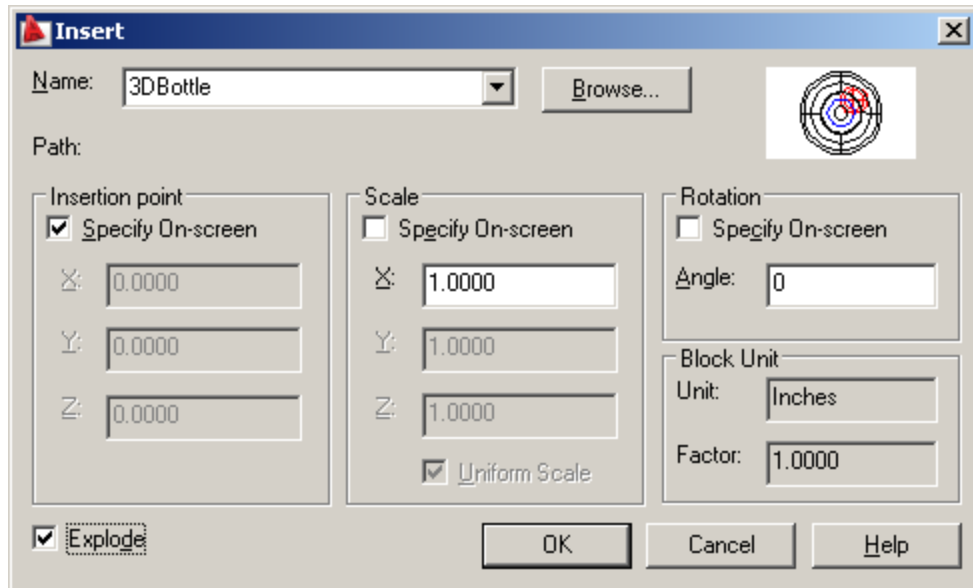

AutoCAD 3D Tutorial

8. Insert the block anywhere in the Model Space view at a scale of 1 and rotation 0.
9. Type ZOOM EXTENTS then ZOOM 1XP.
10. Type PSPACE at the command prompt.
11. Change the layout paper size to ANSIC (22 x17).

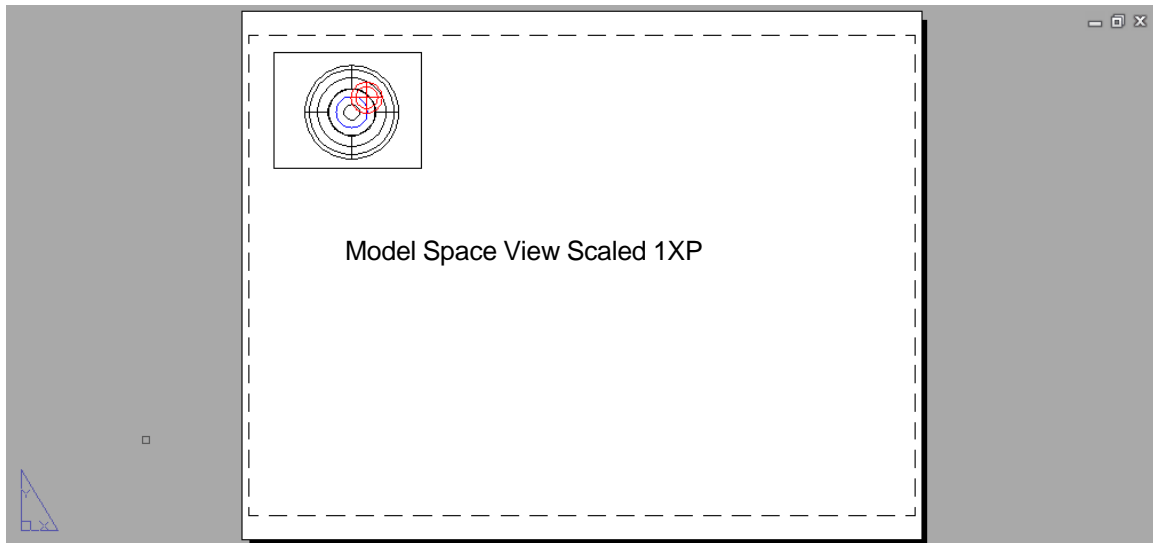

12. Type SOLVIEW at the command prompt.

Command: **solview**

Ucs/Ortho/Auxiliary/Section/<eXit>: **O**

Pick side of viewport to project: **P1**

View center: **P2**

Clip first corner: **P3**

Clip other corner: **P4**

View name: **front**

Ucs/Ortho/Auxiliary/Section/<eXit>:

AutoCAD 3D Tutorial

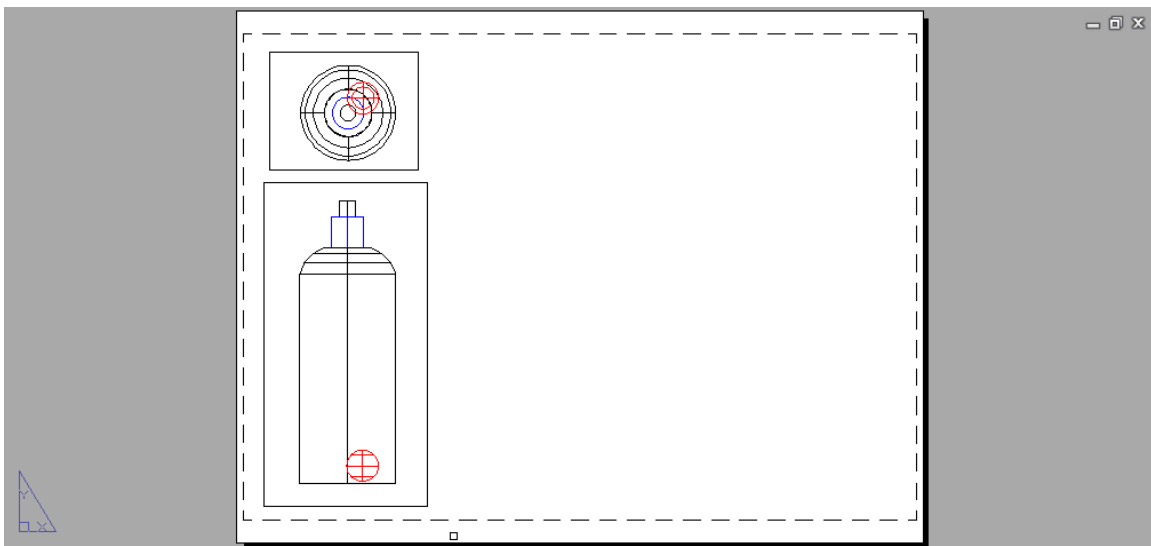

AutoCAD 3D Tutorial

17.10 Soldraw

Generates profiles and sections in viewports created with SOLVIEW. SOLDRAW can only prepare viewports that have been created with SOLVIEW.

1. Choose **Draw, Modeling, Setup, Drawing**.

or

2. Type SOLDRAW at the command prompt

Command: **soldraw**

Select viewports to draw: **Pick viewport created above**

Select objects: 1 found

Select objects: **enter**

3 solids selected.

NOTE: If your object was an inserted block, you need to first explode it so it becomes a solid.

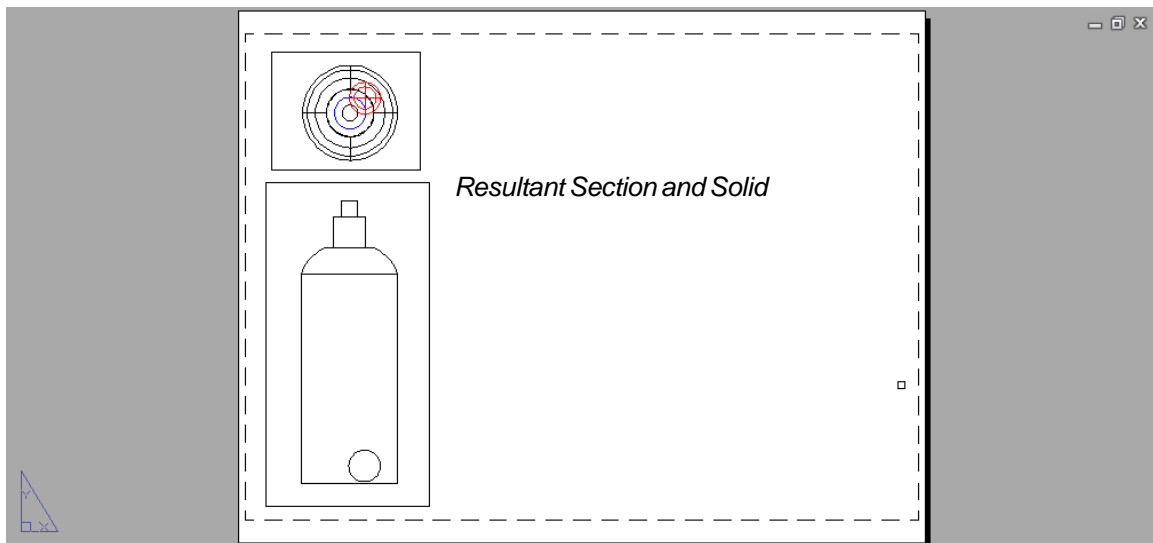

AutoCAD 3D Tutorial

17.11 Create 3D View Using UCS

1. Type **MSPACE** and the plan view of the 3D Bottle.
2. Choose **View, 3D Viewport, SW Isometric...**
3. Type UCS at the command prompt.

Command: **ucs**

Origin/ZAxis/3point/ObjeCt/View/X/Y/Z/
Prev/Restore/Save/Del/?/<World>: **view**

This sets the current UCS parallel to the screen. We now need to save this ucs.

4. Type UCS at the command prompt.

Command: **ucscs** Origin/ZAxis/3point/ObjeCt/View/X/Y/Z/
Prev/Restore/Save/Del/?/<World>: **save**

?/Desired UCS name: **3dview**

5. Click **PSPACE** at the command prompt.
6. Type **SOLVIEW** at the command prompt.

Command: **solview** Ucs/Ortho/Auxiliary/Section/<eXit>:
UNamed/World/?/<Current>: **N**

Name of UCS to restore: 3dview Enter view scale<1.0000>:
enter View center: **pick**

View center: **pick**

Enter view name: **3DVIEW**

AutoCAD 3D Tutorial

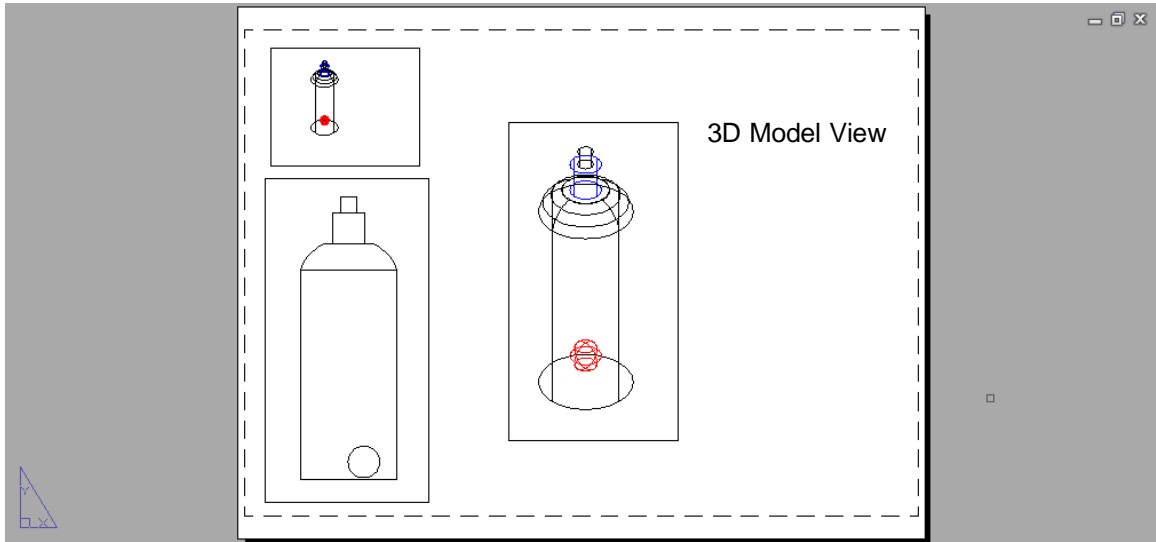

AutoCAD 3D Tutorial

17.12 Solid Profile

1. Double-click MODEL to return to Model Space.
2. Choose **Draw, Modeling, Setup, Profile**.
or
3. Type SOLPROF at the command prompt.
Command: **solprof**
Select objects: **pick solids from the 3DView**
Select objects: **enter**
Display hidden profile lines on separate layer? <Y>: **enter**
Project profile lines onto a plane? <Y>: **enter**
Delete tangential edges? <Y>: **enter**
3 solids selected.

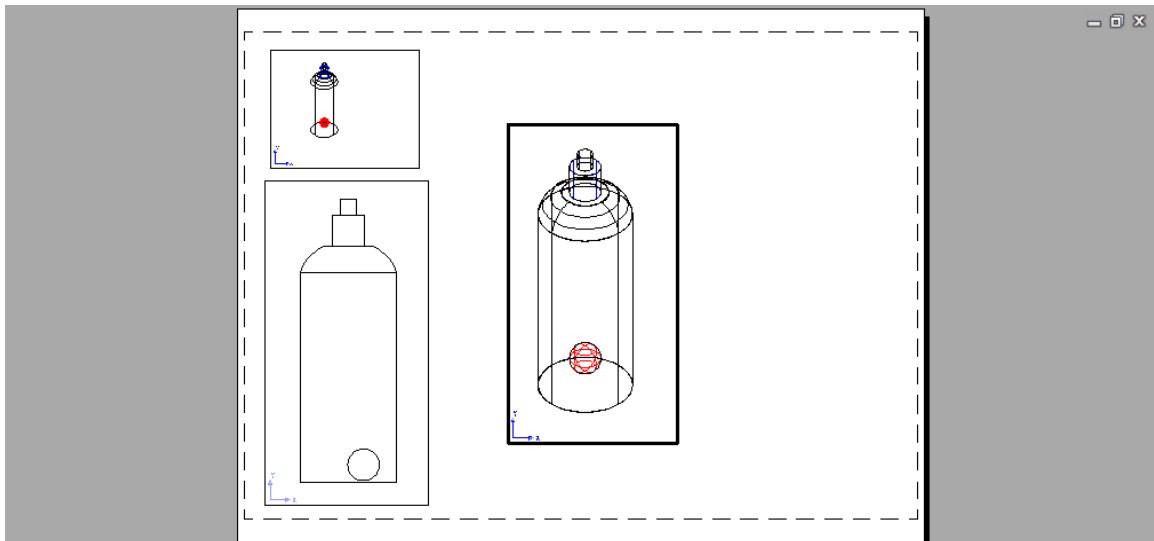

AutoCAD 3D – Chapter 18
Introduction to Rendering

AutoCAD 3D Tutorial

18.1 Render Command

Creates a photorealistic or realistically shaded image of a three-dimensional wireframe or solid model.

1. Open an AutoCAD drawing with 3D objects to render.
2. Choose **View, Render, Render...**

or

3. Type RENDER at the command prompt.

Command: **render**

The following render window is the result of default rendering

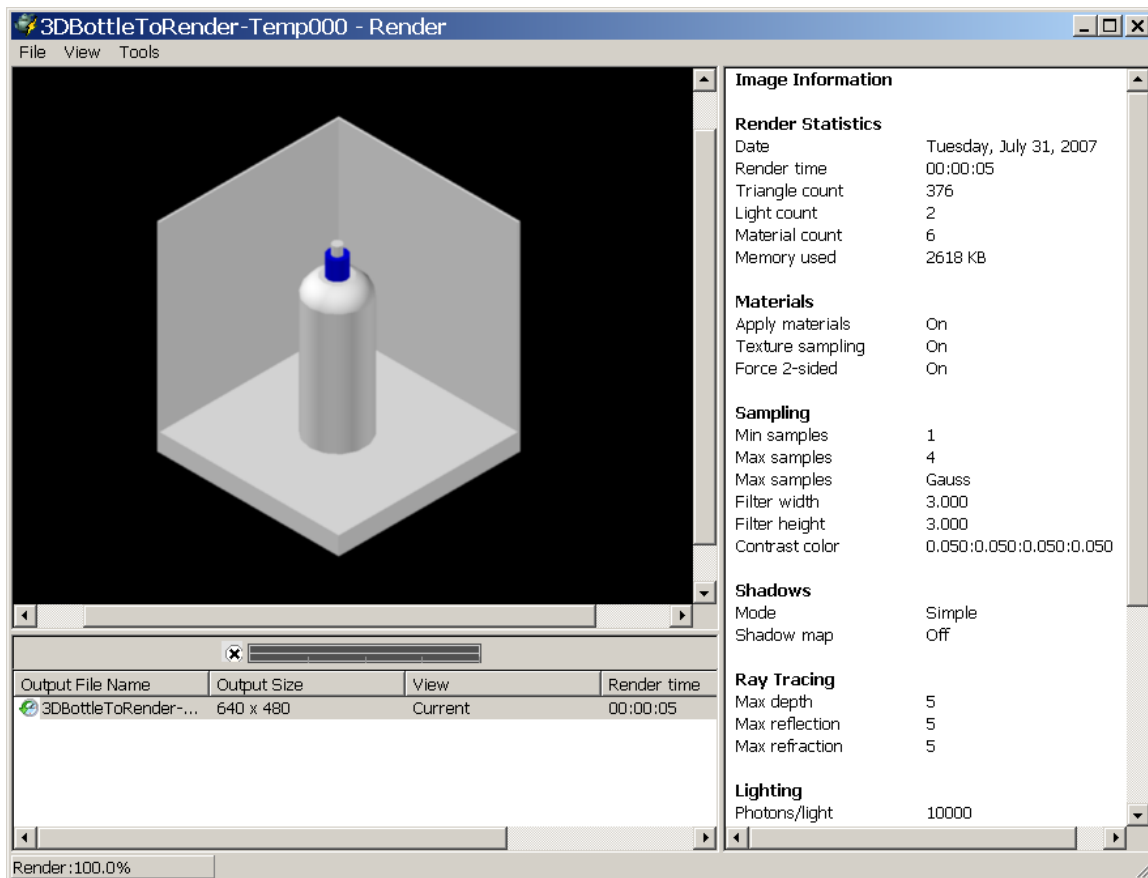

AutoCAD 3D Tutorial

18.2 Render Destination

You are able to determine the output site that the renderer uses to display the rendered image. Two options are the render window and viewport.

1. Open an AutoCAD drawing with 3D objects to render.
2. Choose **View, Render, Advanced Render Settings...**

or

3. Type RPREF at the command prompt.

Command: **rpref**

4. Click the dropdown option for destination and choose **Viewport**.

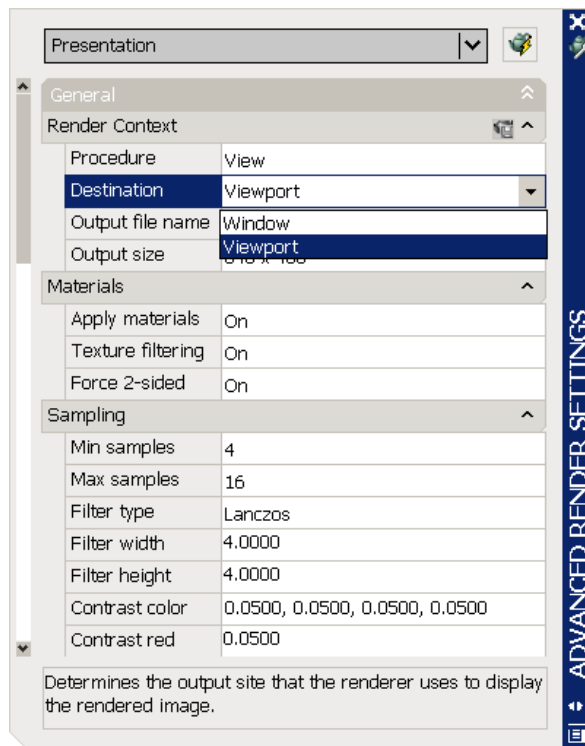

5. Close the render preferences and render your objects to the viewport.

AutoCAD 3D Tutorial

18.3 Render Quality

1. Open an AutoCAD drawing **with 3D objects to render**.
2. Choose **View, Render, Advanced Render Settings...**

or

3. Type RPREF at the command prompt.

Command: **rpref**

4. Click the dropdown option for the render quality and choose **Presentation**.

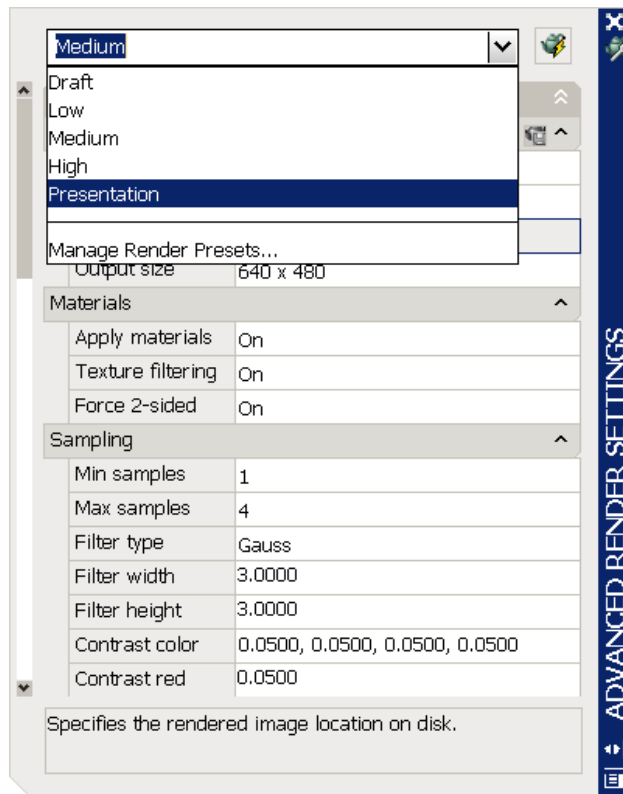

5. Close the render preferences and render your view.

Note: Depending on the objects, lights, materials, etc. in your model, rendering in presentation mode might take a long time.

AutoCAD 3D Tutorial

18.4 Render Selection

Controls the parts of the model that gets processed during rendering. The render procedure has three settings: View, Crop, and Selected.

1. Open an AutoCAD drawing **with 3D objects to render**.
2. Choose **View, Render, Advanced Render Settings...**

or

3. Type RPREF at the command prompt.

Command: **rpref**

4. Click the dropdown option for Procedure and choose **Selected**.

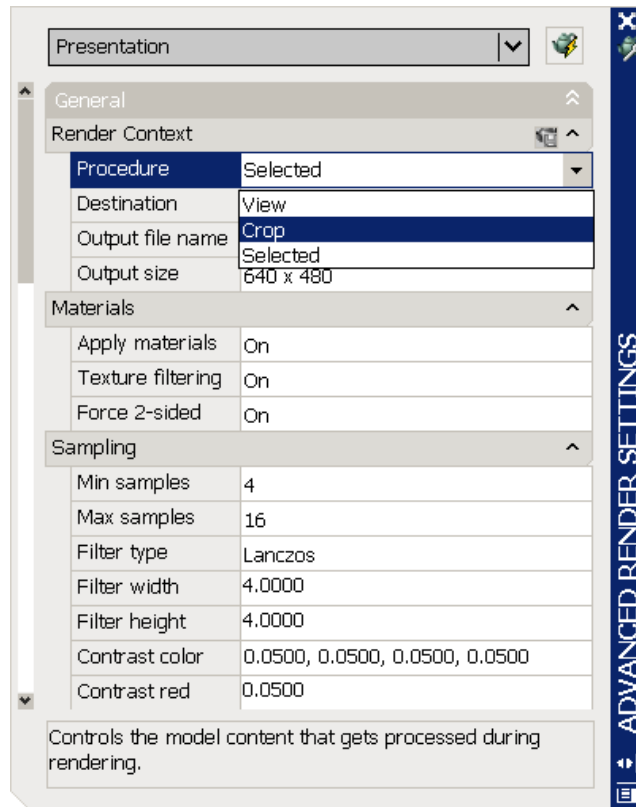

5. Close the render preferences and render your selected objects.

AutoCAD 3D Tutorial

This result is a selected object in the drawing that is rendered.

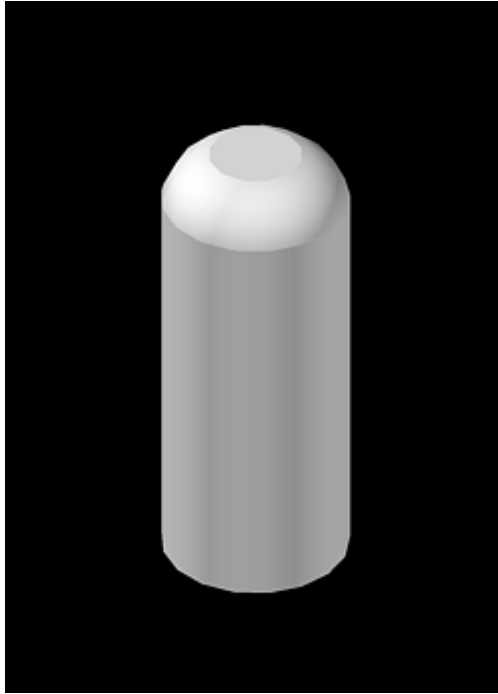

AutoCAD 3D Tutorial

18.5 Render Cropped Window

1. Open an AutoCAD drawing **with 3D objects to render**.
2. Choose **View, Render, Advanced Render Settings...**

or

3. Type RPREF at the command prompt.

Command: **rpref**

4. Click the dropdown option for Procedure and choose **Crop**.

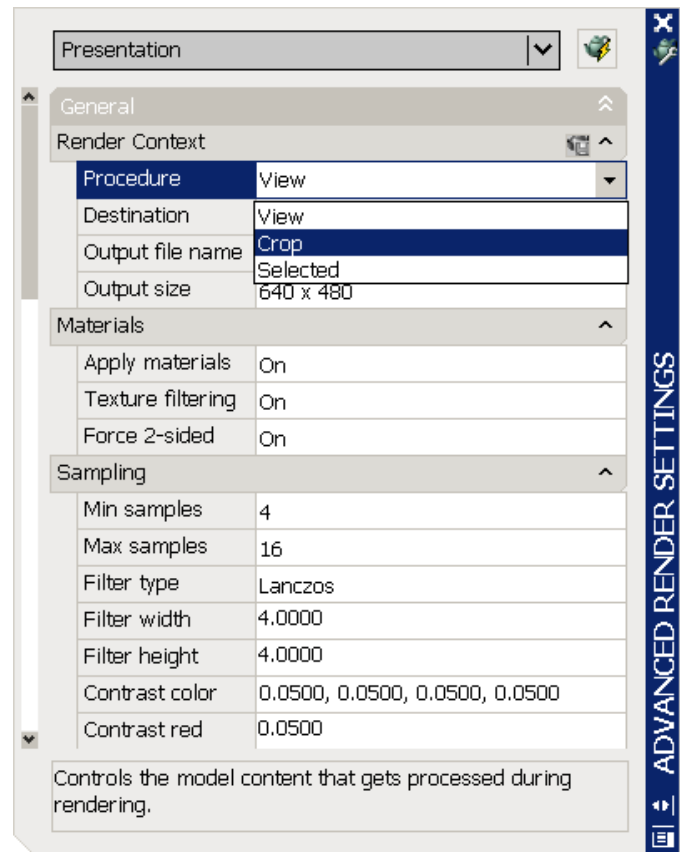

5. Close the render preferences and render your objects.

AutoCAD 3D Tutorial

The result is a cropped portion of the drawing that is rendered.

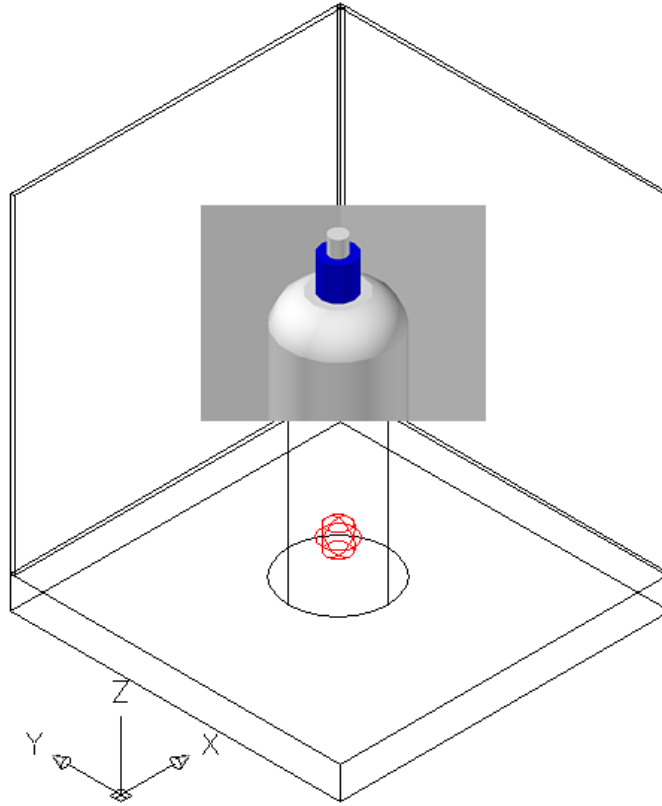

AutoCAD 3D Tutorial

18.6 Render to File

1. Type RPREF at the command prompt.
2. Click the small disk beside the title for “Render Content”.

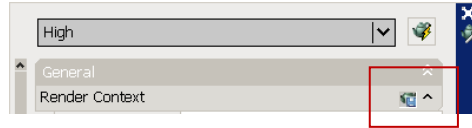

3. Click the option for Output file name.

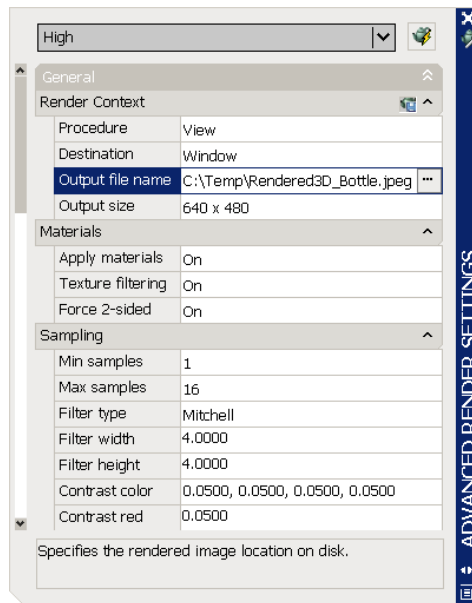

4. Choose a location, format, and file name for your rendered objects.

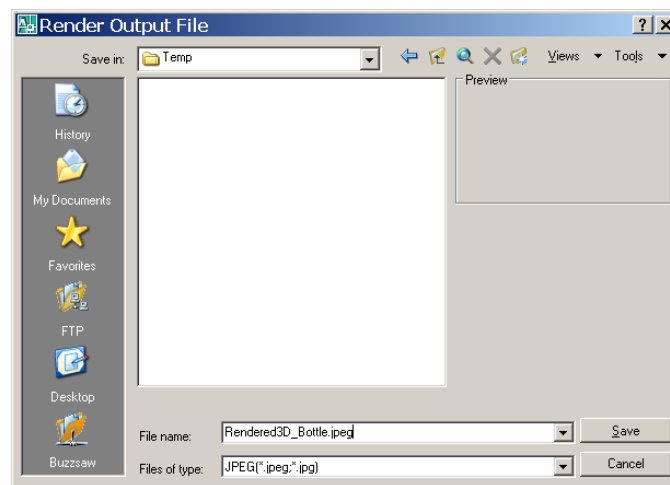

AutoCAD 3D Tutorial

- Adjust the image quality and click OK.

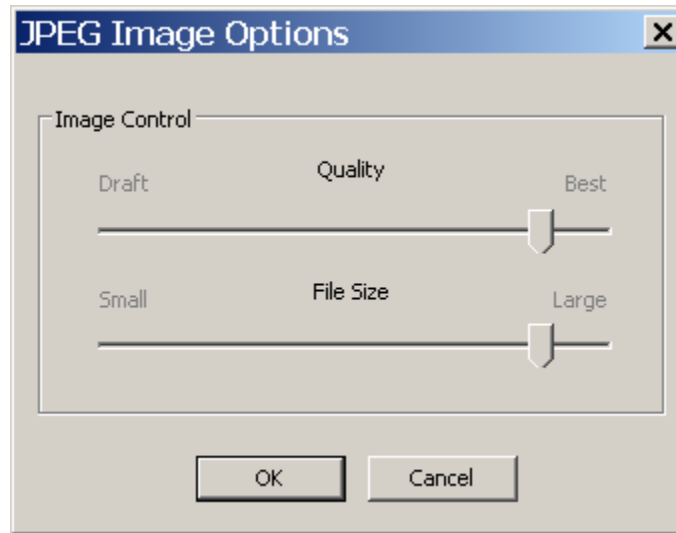

- Close the render preferences and render your objects.

The result is a rendered image to a file that you can copy , print, or manipulate in any imaging software application.

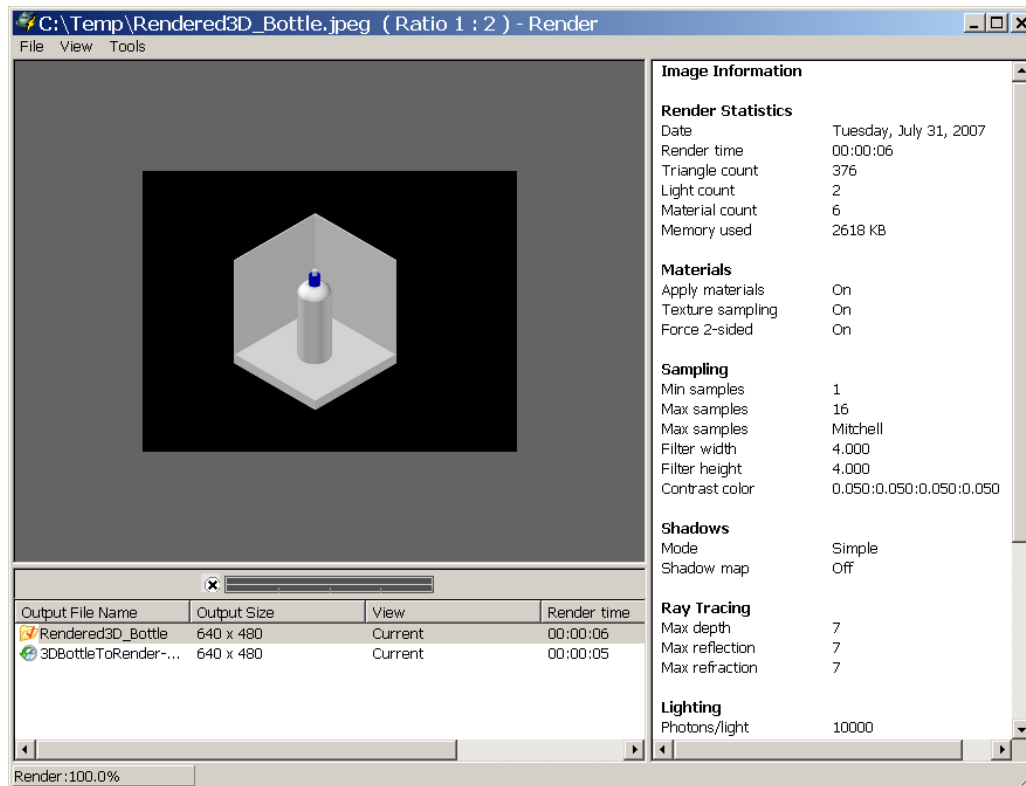

AutoCAD 3D Tutorial

18.7 Turn Off Render to File

1. Open an AutoCAD drawing **with 3D objects to render**.
2. Choose **View, Render, Advanced Render Settings...**

or

3. Type RPREF at the command prompt.

Command: **rpref**

4. Click the small disk beside the title for “Render Content”. You will notice that the Output file name option will be grayed out.

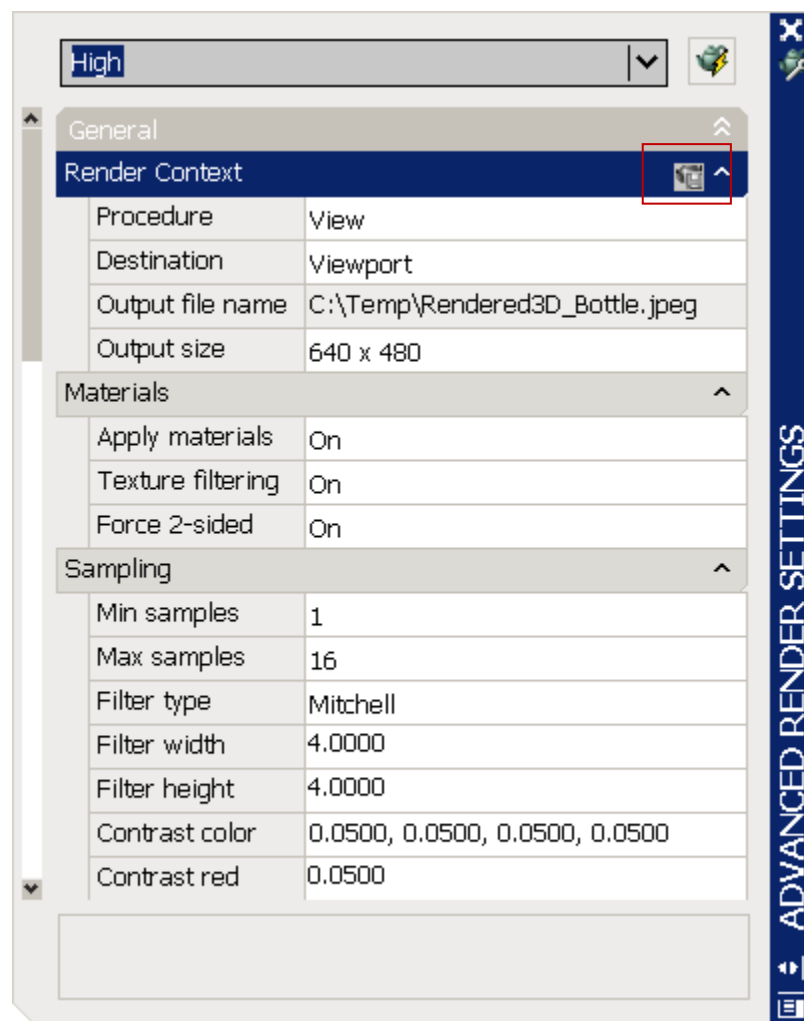

AutoCAD 3D – Chapter 19
Materials

AutoCAD 3D Tutorial

19.1 Adding Material to a Drawing

1. Open an AutoCAD drawing with 3D objects to add materials to.
2. Choose **View, Render, Materials...**
or
3. Type MATERIALS at the command prompt.
Command: **materials**
4. Click the **Create New Material Button** under the Available Materials in Drawing section.

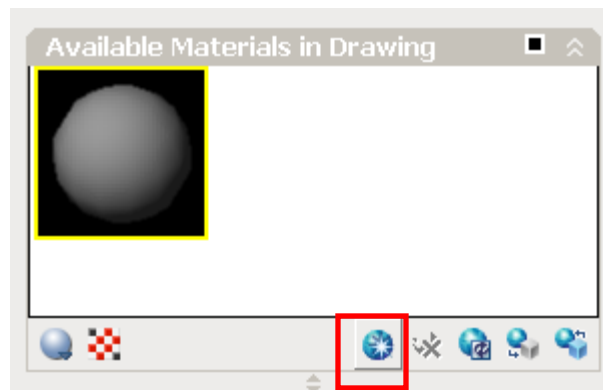

5. Type a name and description for the new material.



6. Click the **Select Image...** button under the **Diffuse Map** section of the Material Editor.

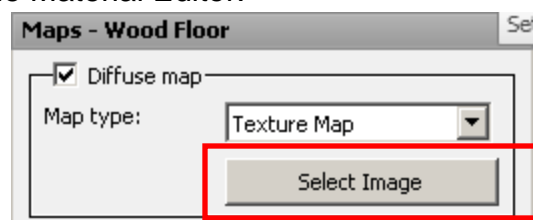

AutoCAD 3D Tutorial

7. Navigate to a location where material textures are located, select a material image to add, and click Open.

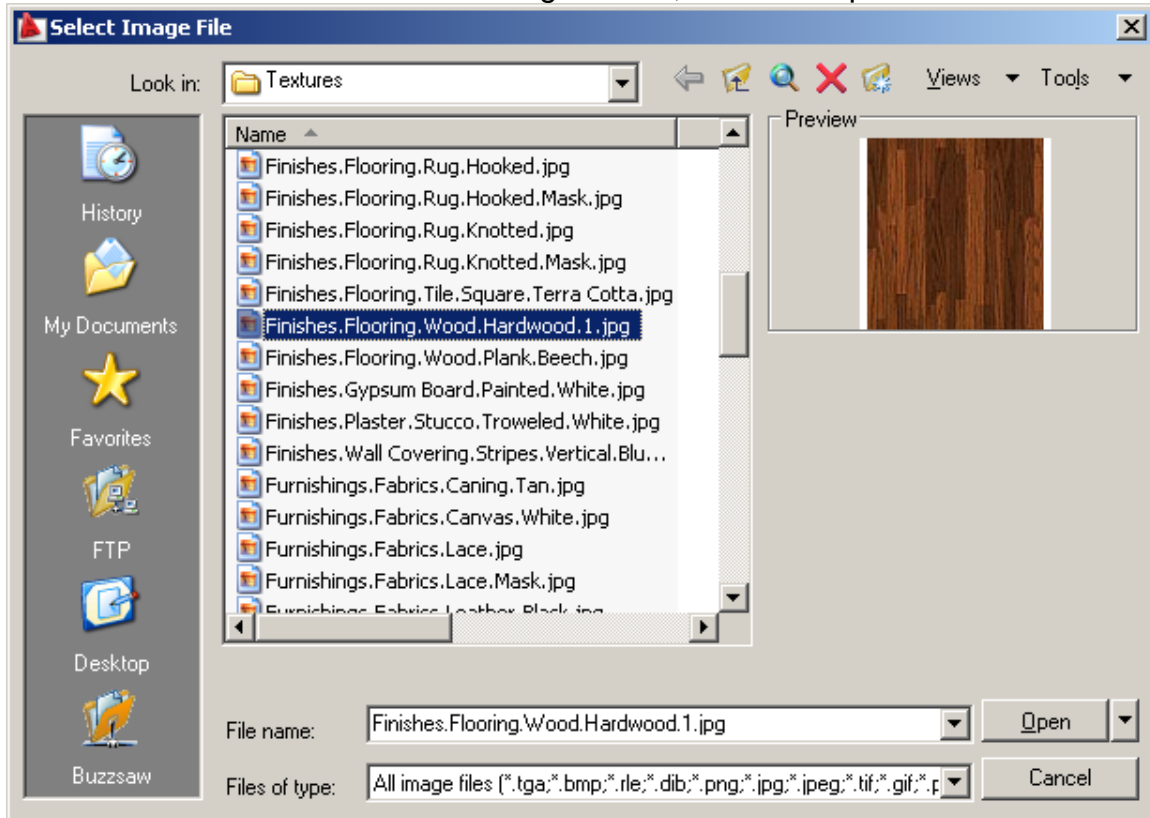

The material will be added to your drawing in the current material slot.

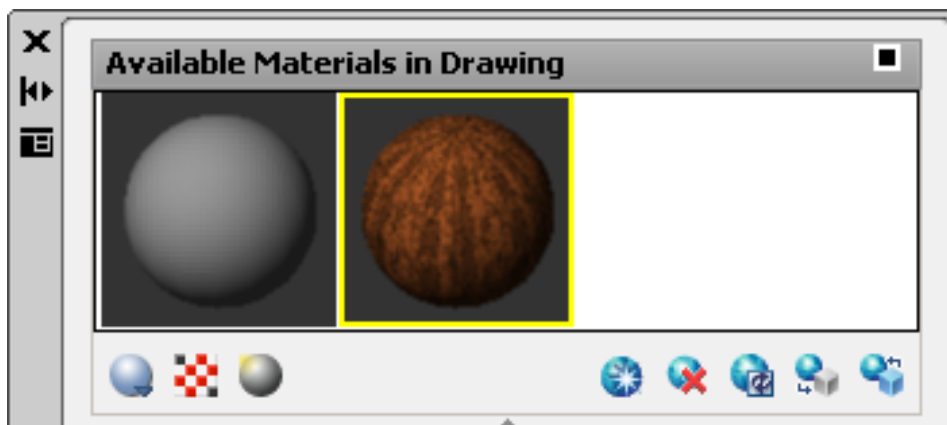

AutoCAD 3D Tutorial

19.2 Applying Materials by Attach

1. Choose **View, Render, Materials...**
or
2. Type MATERIALS at the command prompt.
Command: **materials**
3. Click the **Apply Material to Objects** button under the **Available Materials in Drawing** section.

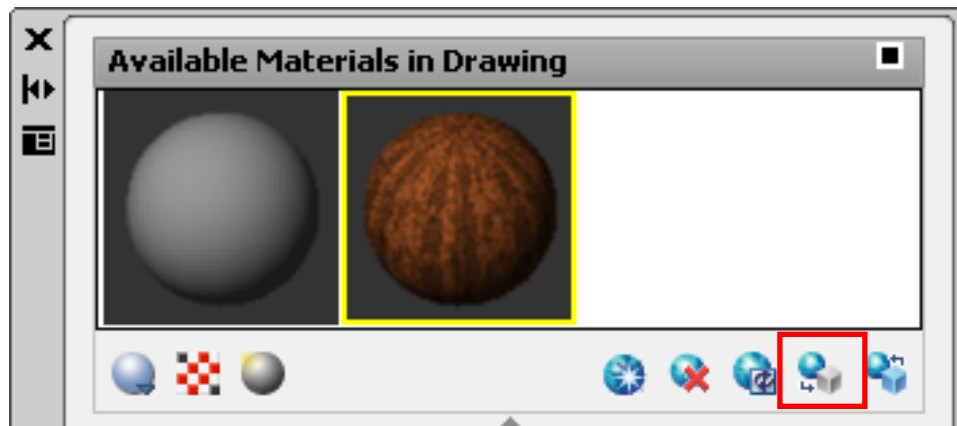

4. Use the pick box to select an object to apply the material to (e.g. base).

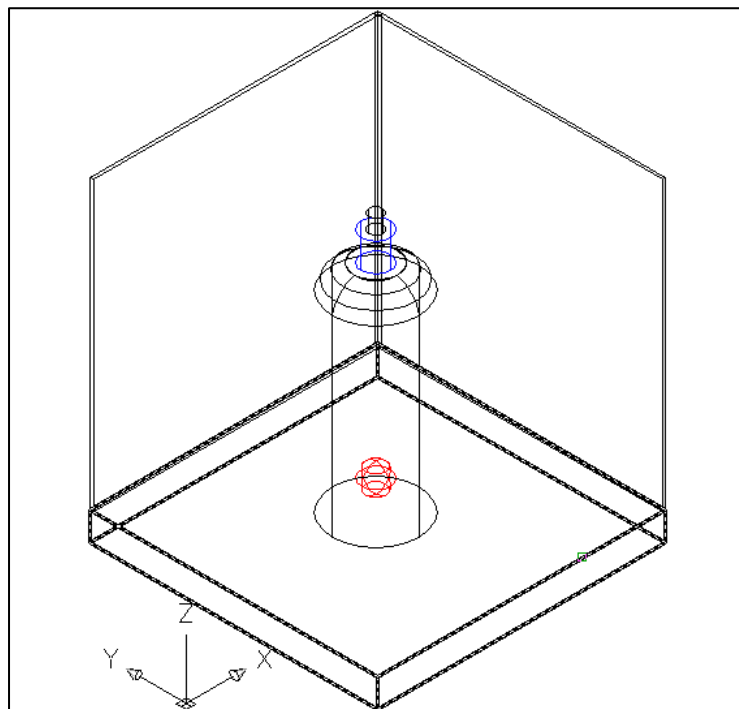

AutoCAD 3D Tutorial

5. Press **enter**.
6. Type **RENDER** at the command prompt to see the new material applied in the drawing.

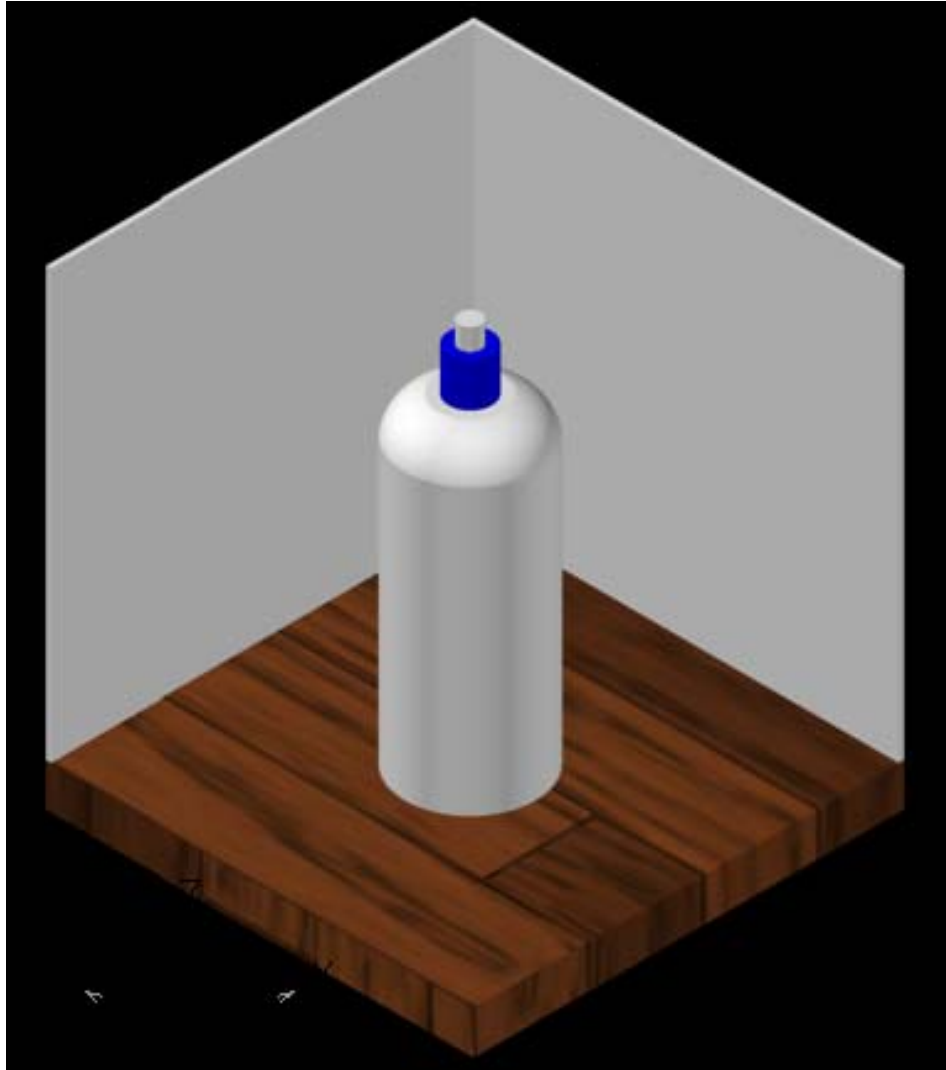

AutoCAD 3D Tutorial

19.3 Adjust Material Scale

Materials such as hard wood might not map properly to objects at different scales. The follow section shows how to adjust the scale of materials.

1. Choose **View, Render, Materials...**
or
2. Type MATERIALS at the command prompt.
Command: **materials**
3. Click the **Texture Map Settings** button under the Diffuse Map section of the Material Editor.

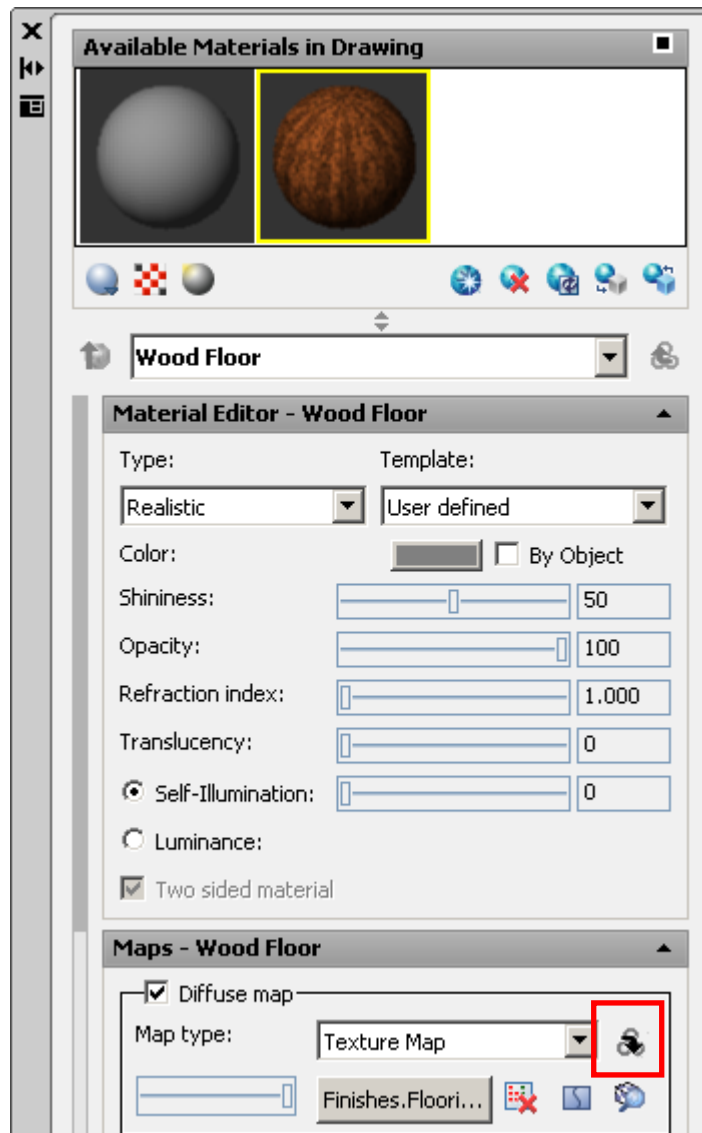

AutoCAD 3D Tutorial

4. Double-click **Scaling & Tiling**.
5. Click the lock icon to scale the materials evenly in both directions.
6. Change the U and V tile settings to make the material smaller or larger.

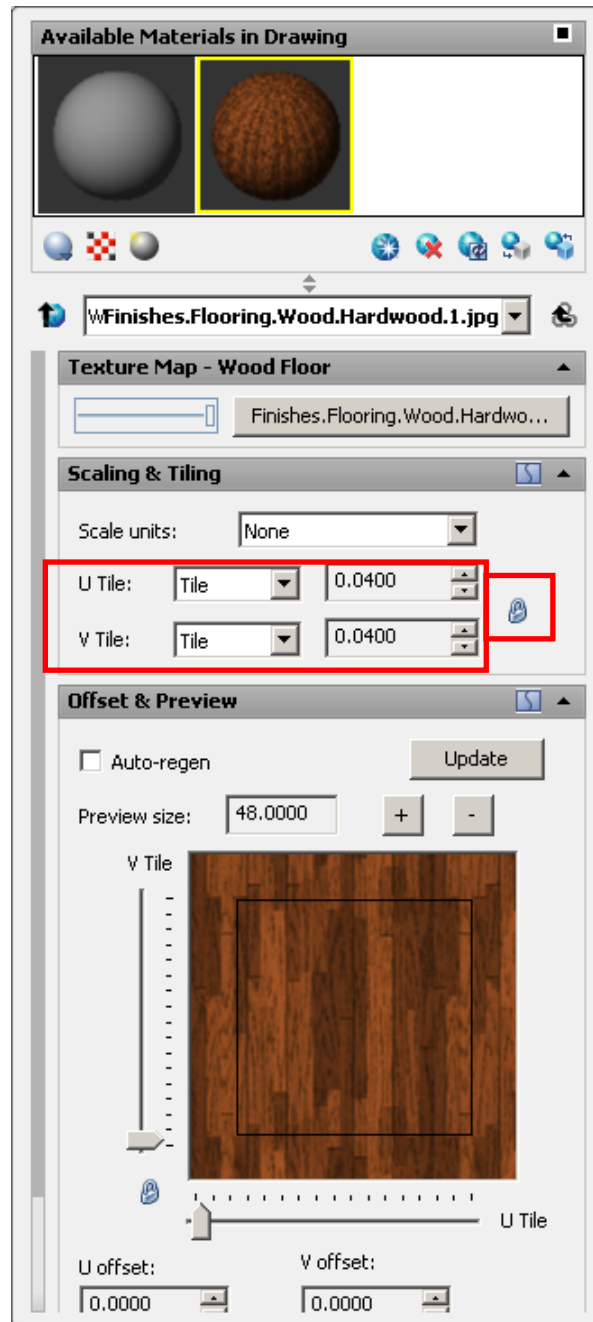

7. Render the drawing to see the newly mapped material.

AutoCAD 3D Tutorial

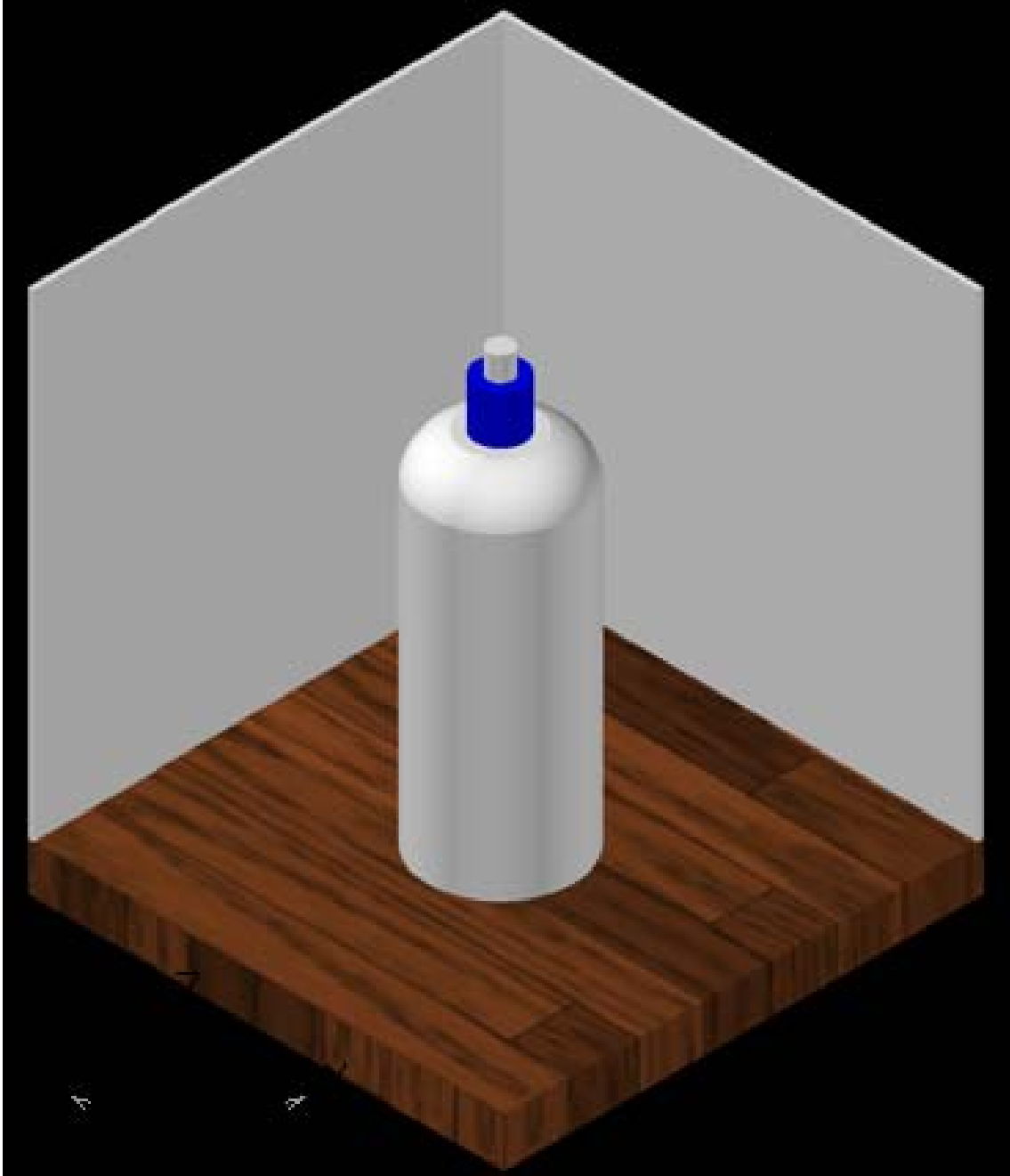

Add the following additional material to your drawing:

Concrete.Cast-In-Place.Flat.Grey.Efflorescence.jpg

AutoCAD 3D Tutorial

19.4 Applying Materials by Layer

You can attach a material to an entire layer using the Material Attach command.

1. Type MATERIALATTACH at the command prompt.

Command: **materialattach**

2. Click and drag the concrete material onto layer Wall.

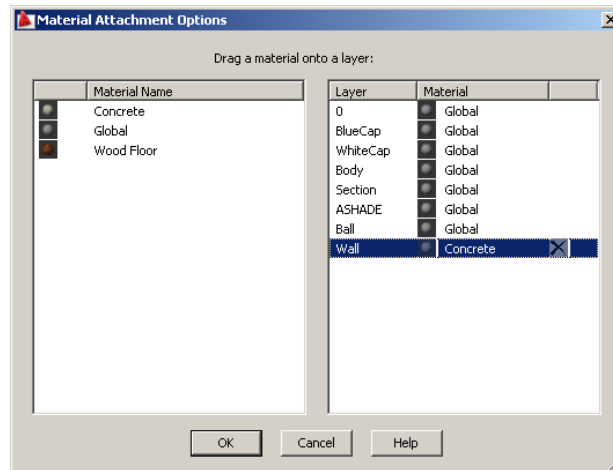

3. Adjust the material to the object and render to see the results.

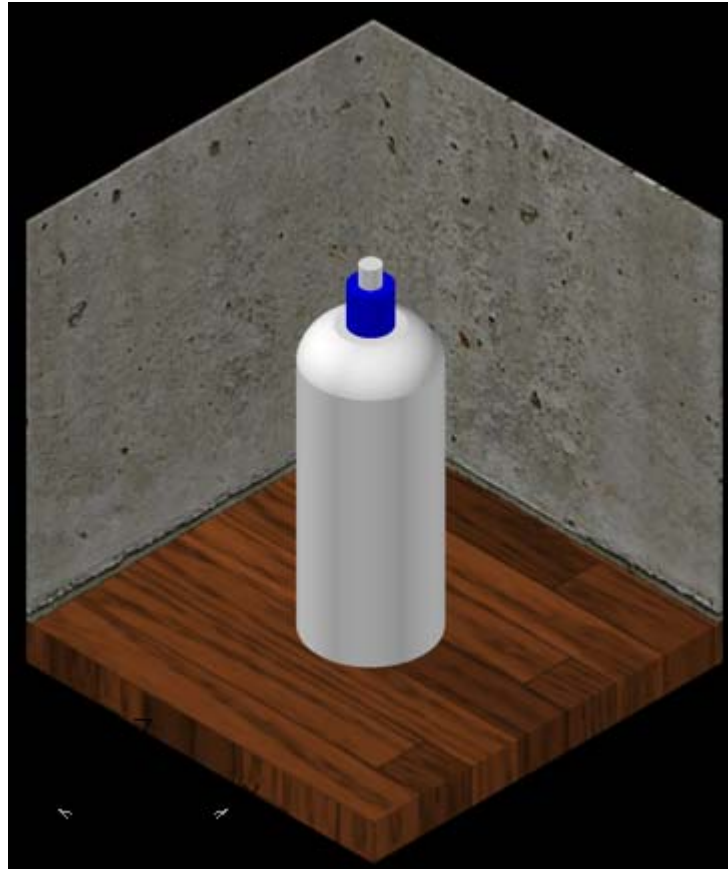

AutoCAD 3D Tutorial

19.5 New Materials

1. Choose **View, Render, Materials...**
or
2. Type MATERIALS at the command prompt.
Command: **materials**
3. Click the **Create New Material** button and create a material called **Glass** for the bottle.
4. From the Template dropdown, click **Glass - Clear**.
5. Click the **Checked Underlay** option to see the glass properties.

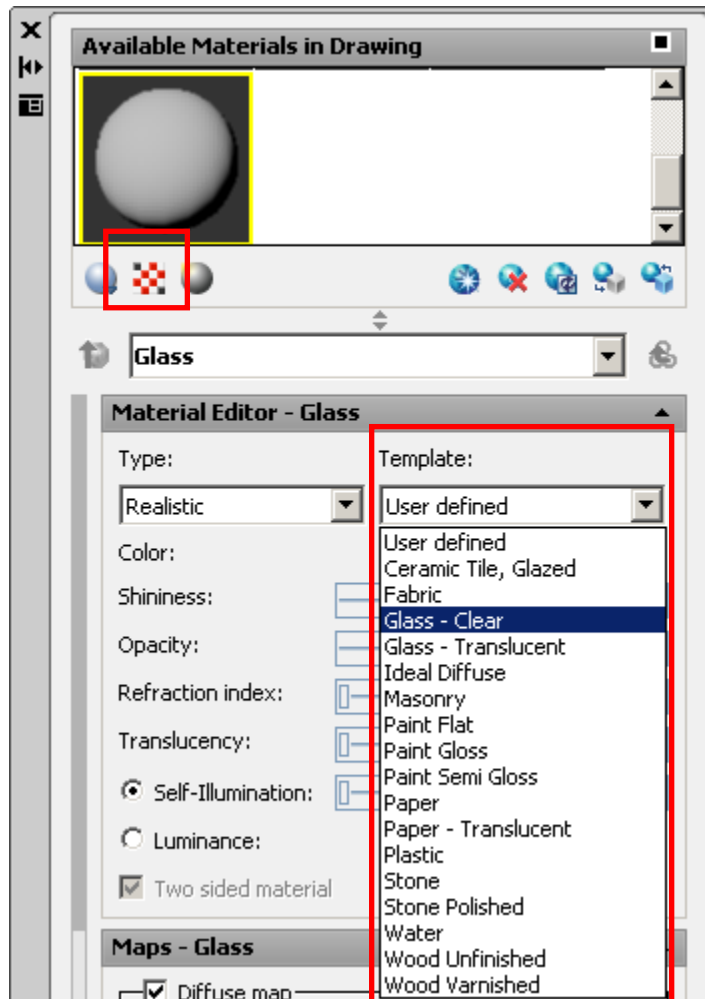

6. Adjust other glass properties as desired and apply the material to the bottle.

AutoCAD 3D Tutorial

6. Change the material's translucency to **90** and apply the material to the bottle.

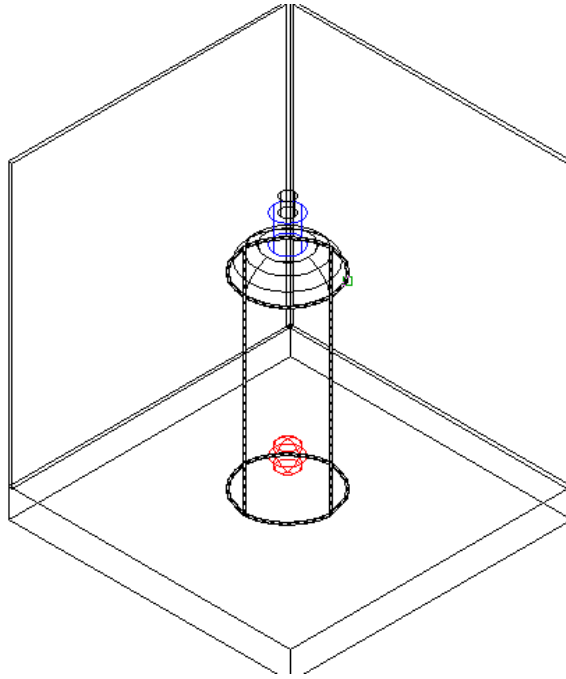

7. Render the drawing.



AutoCAD 3D Tutorial

19.6 Add Photo as Material

1. Choose **View, Render, Materials...**
or
2. Type MATERIALS at the command prompt.
Command: **materials**
3. Click the **Create New Material** button and create a material called **Photo**.
4. Click the **Select Image...** button under the **Diffuse Map** section of the Material Editor.
5. Navigate to the location where the AutoCAD 3D files are located and choose **YoungGirl.JPG** (or a similar photo).

The photo is added as an image material

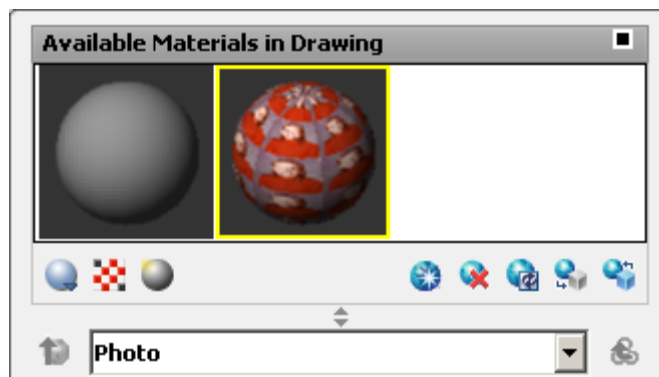

6. Choose the dropdown option for geometry swatch and choose the cube.

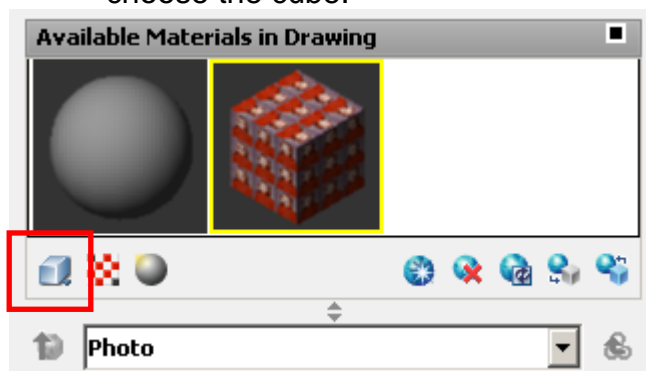

AutoCAD 3D Tutorial

7. Apply the material to the 3D face in the drawing.

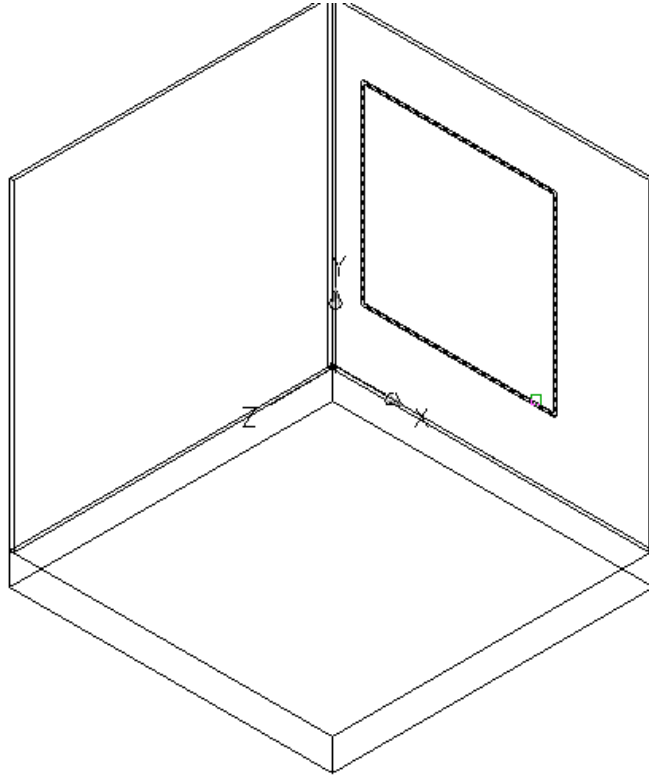

8. Render the viewport.

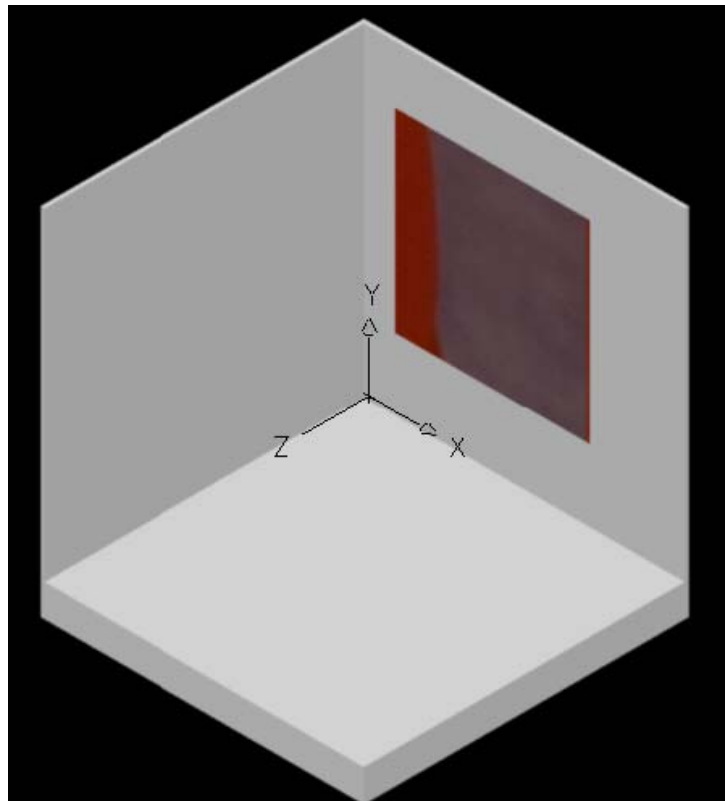

AutoCAD 3D Tutorial

9. Select the 3D face.
10. Change the scaling and sizing settings to the following:

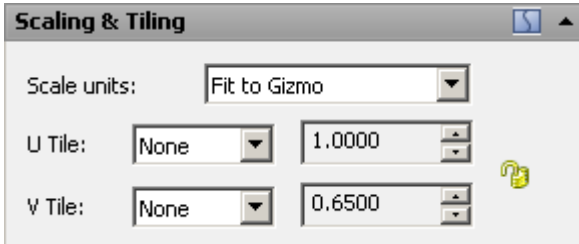

11. Render the viewport.

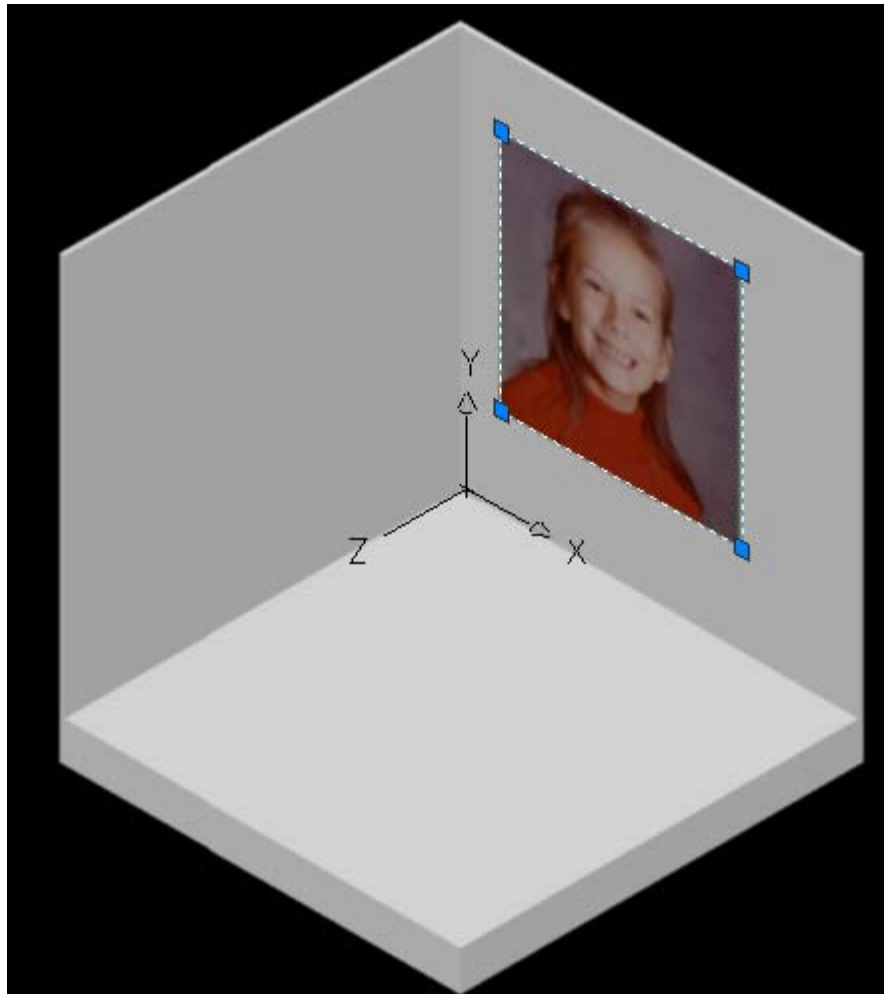

AutoCAD 3D Tutorial

19.7 Material Mapping

1. Open a drawing with a box, cylinder, and sphere.
2. Attach an image material to the above objects and scale it to “Fit to Gizmo” with tiling set to None and a scale of 1.00.

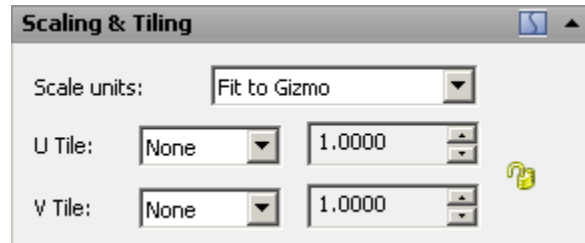

3. Render the drawing.

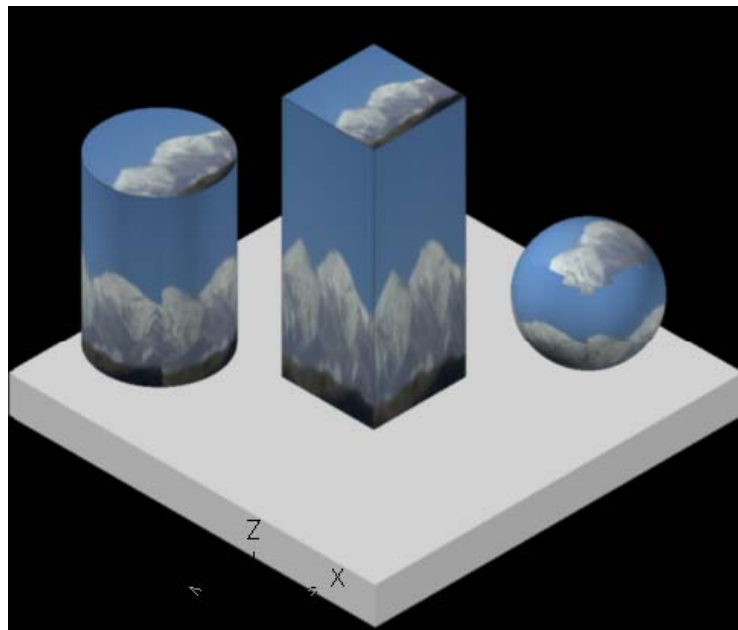

2. Type MATERIALMAP at the command prompt.
Command: **MATERIALMAP**
3. Choose Cylinder and then pick the cylinder in the drawing.

AutoCAD 3D Tutorial

4. Use the grips to move the mapping plane along the cylinder.

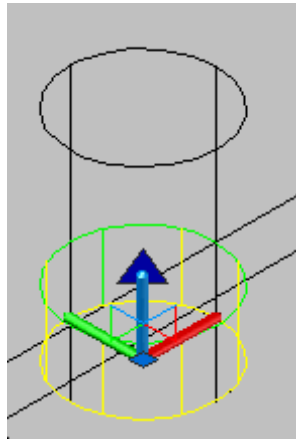

5. Press enter and render the drawing.



6. Practice changing the image as it appears on the box and cylinder.

AutoCAD 3D Tutorial

19.8 Removing Materials from Objects

1. Type RPREF at the command prompt.
2. Choose the remove material icon to remove a material from an object.

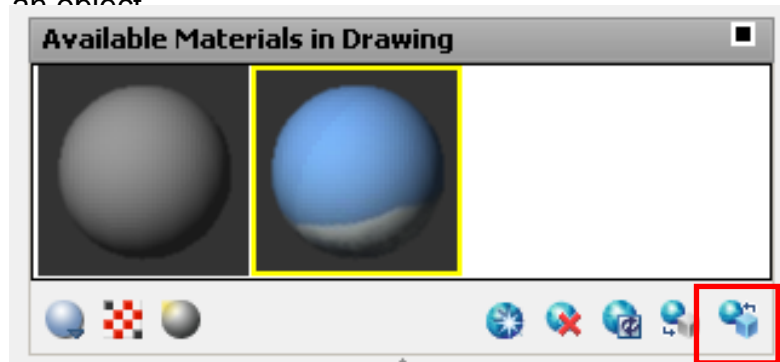

19.9 Purge Materials from Drawings

1. Type RPREF at the command prompt.
2. Click a material to remove.
3. Choose the remove material icon to remove a material from an object.

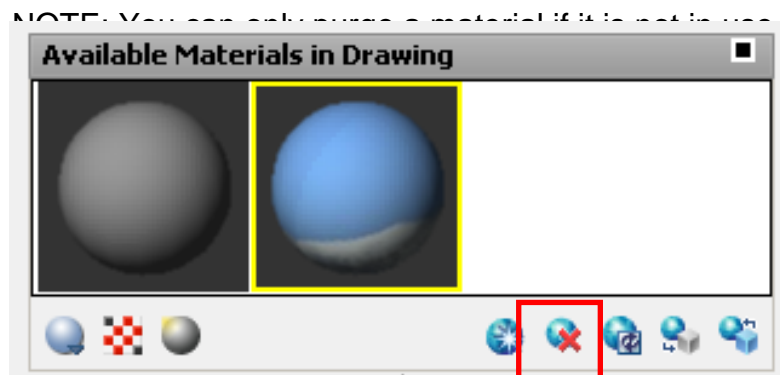

AutoCAD 3D Tutorial

19.10 Opacity Materials

1. Choose **View, Render, Materials...**
or
2. Type MATERIALS at the command prompt.
Command: **materials**
3. Click the **Create New Material** button and create a material called **Opacity Material**.
4. Click Select Image under the Opacity map option and choose the opacity material.
5. Click Select Image under the Diffuse map option and choose the texture (image).
6. Apply the material to the object.
7. Set the scale and tiling as below.

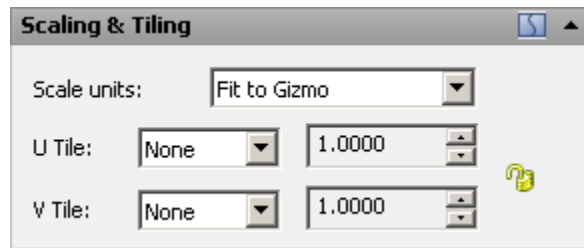

8. Render the viewport.
9. If necessary, explode the solid and delete unnecessary faces and render again.

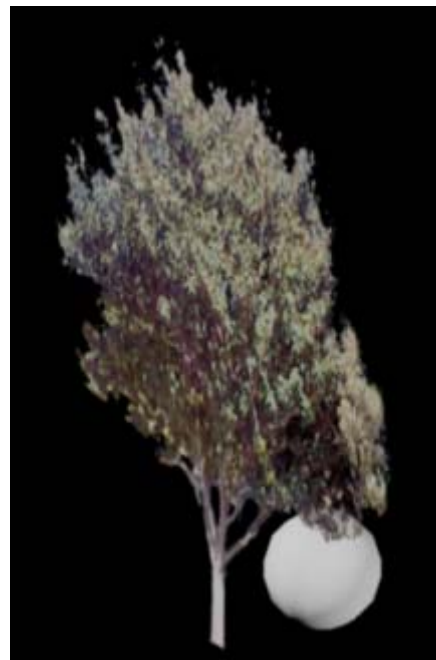
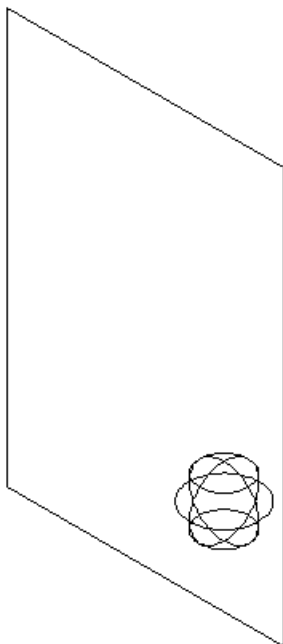

AutoCAD 3D Tutorial

19.11 Bump Map Materials

1. Choose **View, Render, Materials...**
or
2. Type MATERIALS at the command prompt.
Command: **materials**
3. Click the **Create New Material** button and create a material called **Bump Material**.
4. Click **Select Image** under Bump Map and choose a bump material.

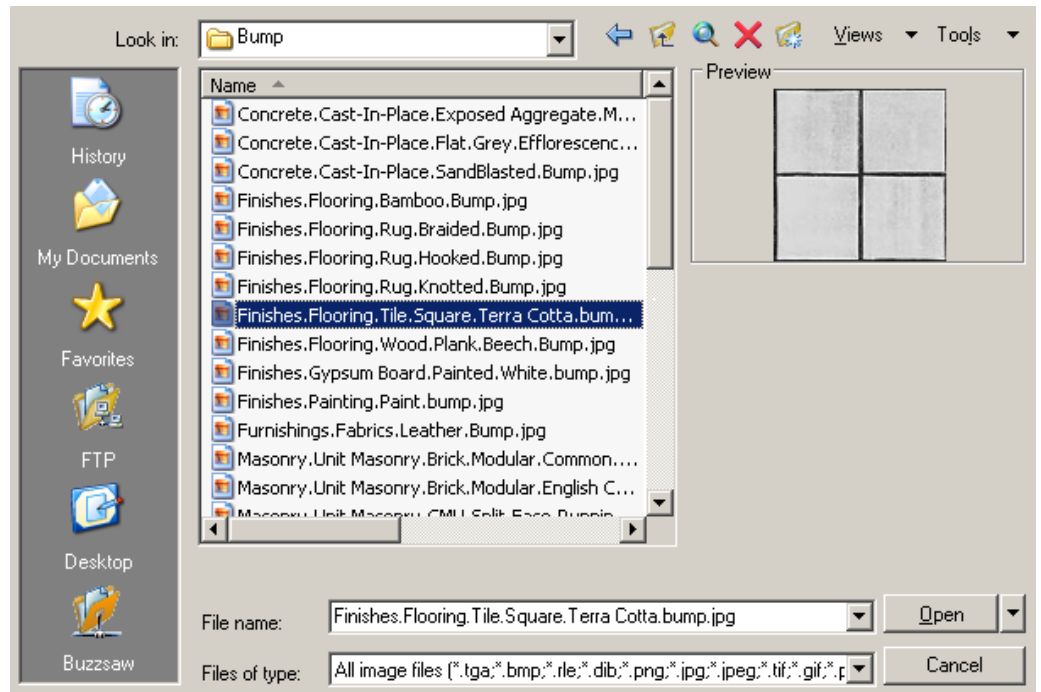
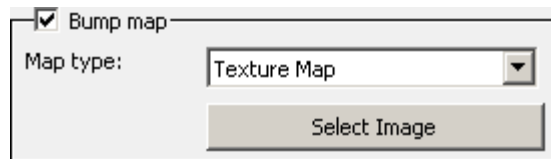

5. Click **Select Image** under Diffuse Map and choose the same image as the bump material, this time the actual material.

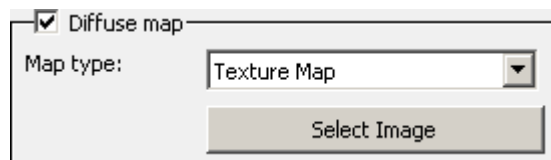

AutoCAD 3D Tutorial

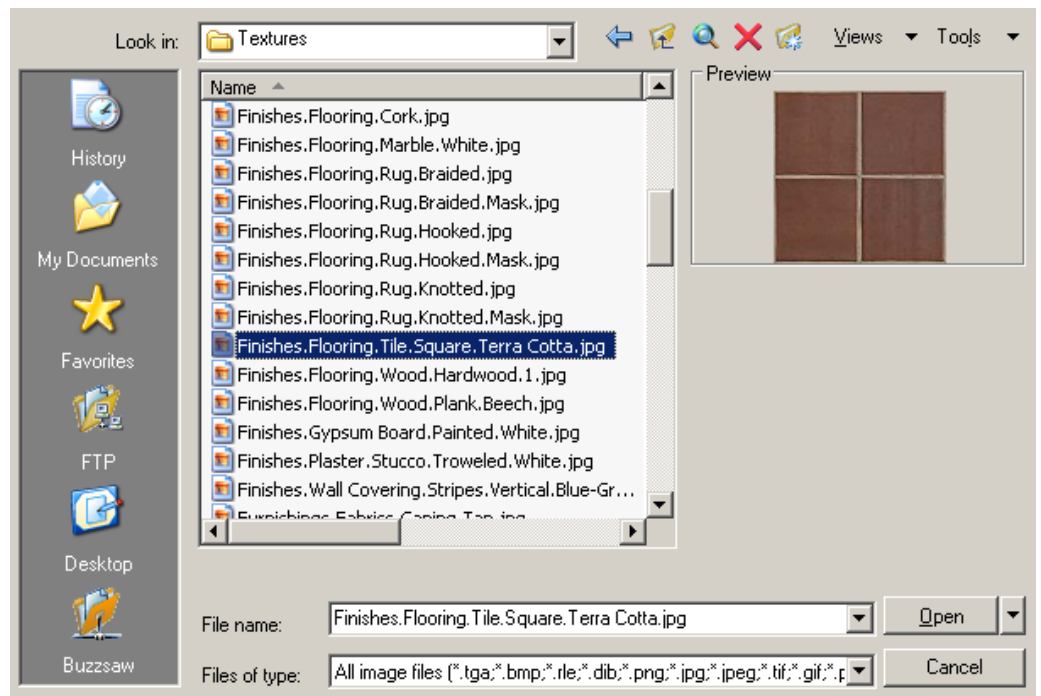

6. Apply the material to the base in the drawing and set the following parameters:



7. Render the viewport.

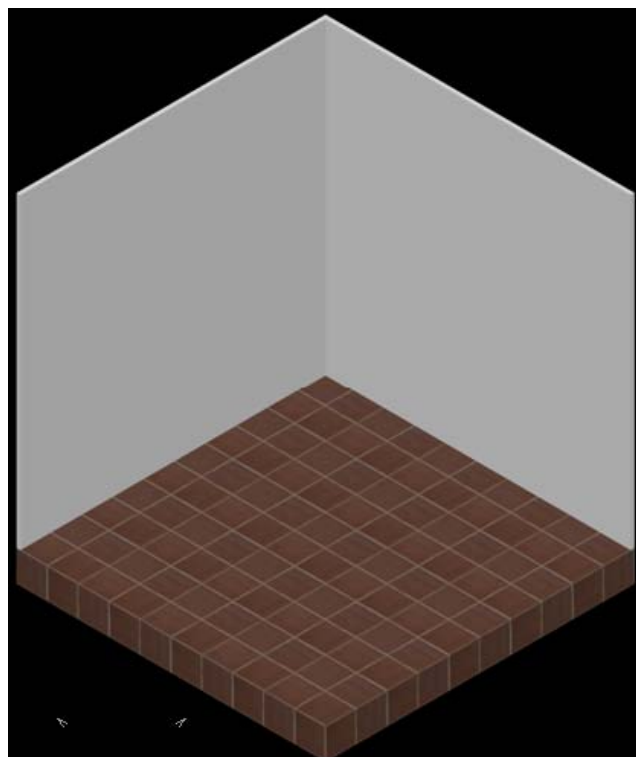

AutoCAD 3D Tutorial

19.12 Materials ON/OFF

1. Open a drawing with materials and textures added.
2. Set the Visual Style to Realistic.

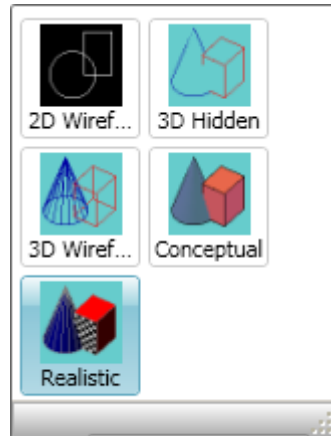

3. Choose Materials OFF from the Materials ribbon or type VSMATERIALMODE at the command prompt.

Command: **_VSMATERIALMODE**

Enter new value for VSMATERIALMODE <2>: 0

0=Materials OFF/Textures OFF

1= Materials ON/Textures OFF

2=Materials ON/Textures ON

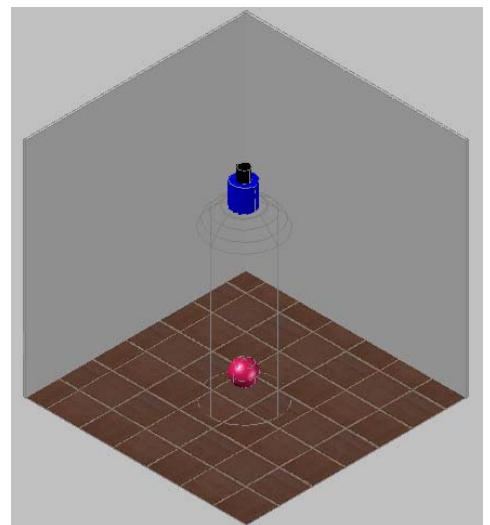
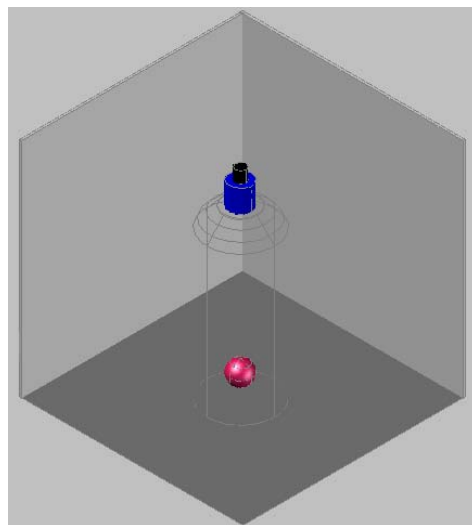
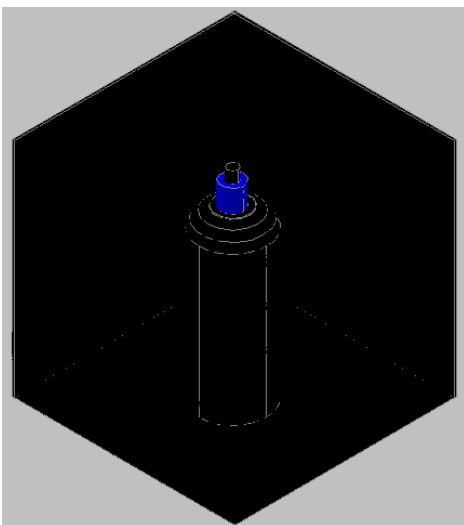

AutoCAD 3D – Chapter 20
Lights

20.1 Default Lighting

When there are no lights in a scene, the scene is shaded with default lighting. Default lighting is derived from two distant sources that follow the viewpoint as you move around the model. All faces in the model are illuminated so that they are visually discernible. You can control brightness and contrast, but you do not need to create or place lights yourself.

When you insert custom lights or add sunlight, you can disable the default lighting. You can apply default lighting to the viewport only; at the same time, you can apply custom lights to the rendering.

ON/OFF

1. Choose Default Lighting from the Lighting ribbon or type `DEFAULTLIGHTING` at the command prompt.

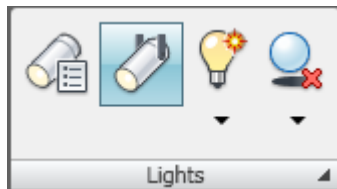

Command: `_defaultlighting`

Enter new value for `DEFAULTLIGHTING` <0>: 1

AutoCAD 3D Tutorial

20.2 Point Lights

A point light radiates light in all directions from its location.

1. Open a drawing with 3D objects and display in a 3D view.
2. Choose **View, Render, Light, New Point Light**.

or

3. Type POINTLIGHT at the command prompt.

Command: **pointlight**

4. Click Turn Off default lighting in the following prompt if default lighting was on:

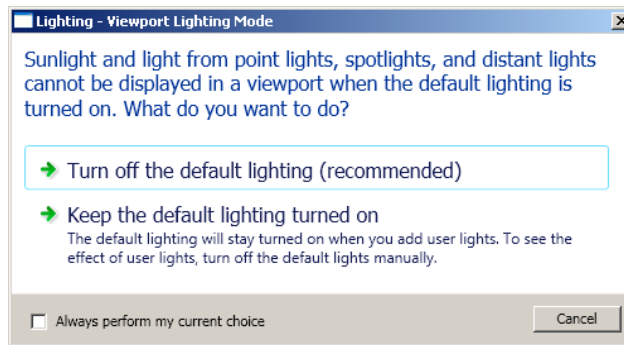

Specify source location <0,0,0>: **.XY**

of pick bottom center of bottle

(need Z): **15**

Enter an option to change

[Name/Intensity/Status/shadoW/Attenuation/Color/eXit]

<eXit>: **enter**

5. Render the current viewport.

AutoCAD 3D Tutorial

View rendered using a point light

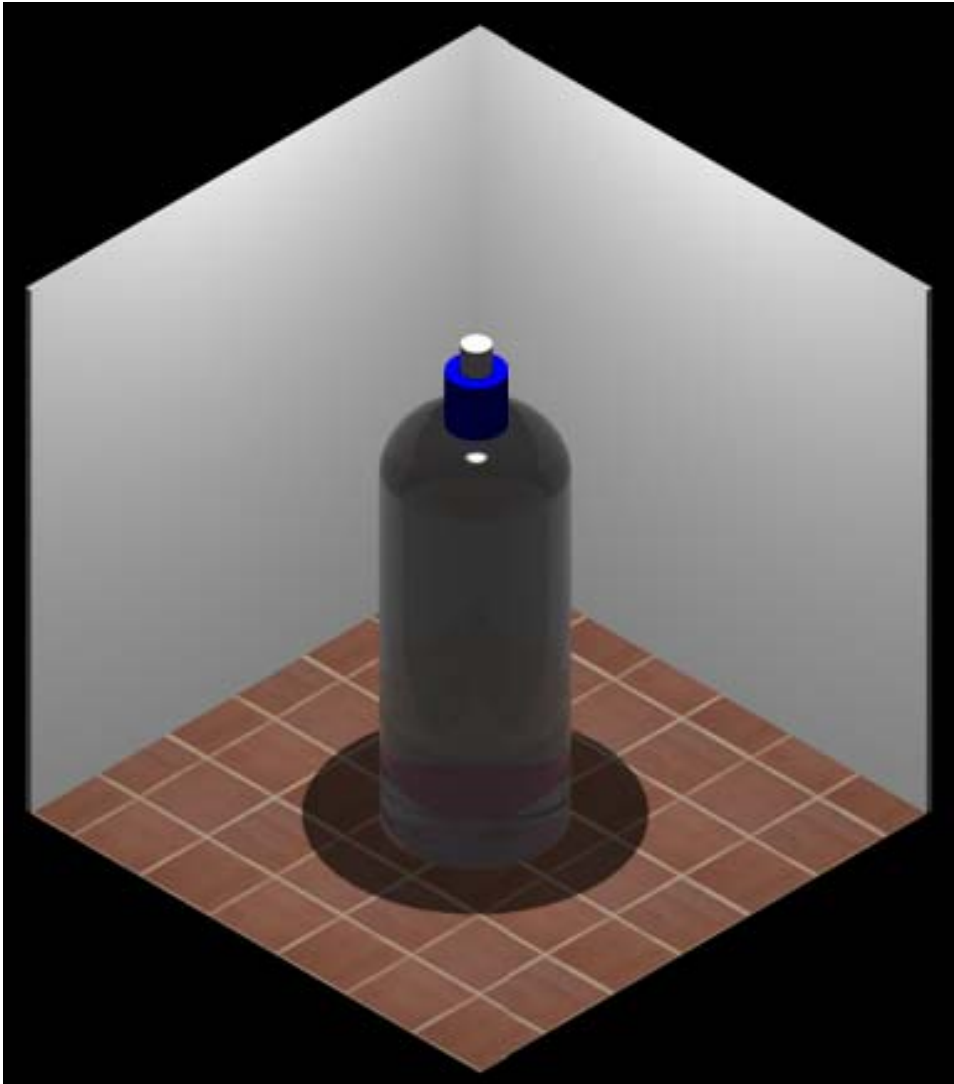

AutoCAD 3D Tutorial

20.3 Spot Lights

A spotlight emits a directional cone of light.

1. Open a drawing with 3D objects and display in a 3D view.
2. Choose **View, Render, Light, New Spot Light**.

or

3. Type SPOTLIGHT at the command prompt.

Command: **spotlight**

Specify source location <0,0,0>: **P1**

Specify target location <0,0,-10>: **P2**

Enter an option to change

[Name/Intensity/Status/Hotspot/Falloff/shadoW/Attenuation/Color/eXit] <eXit>: **enter**

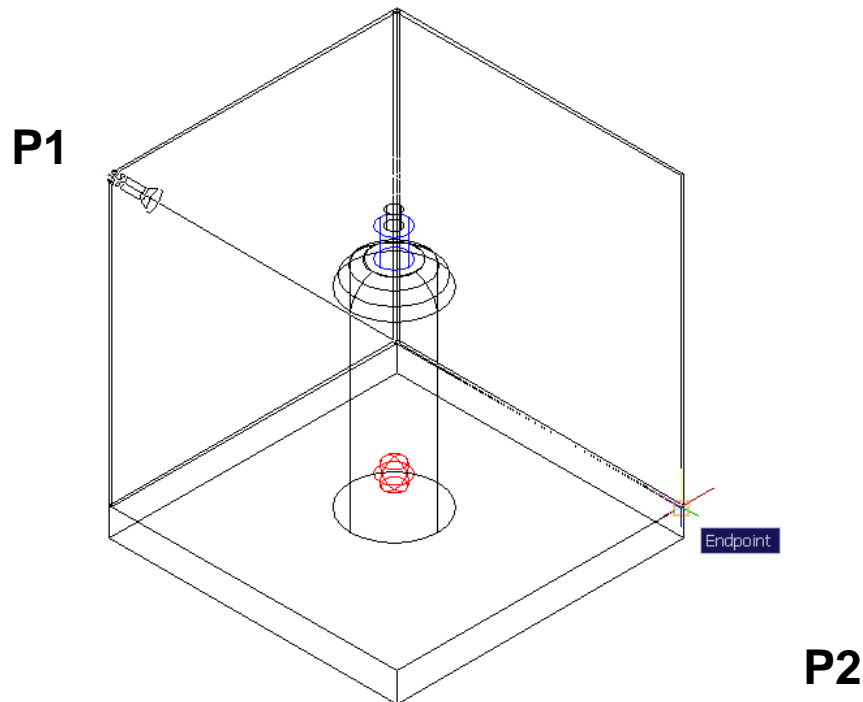

4. Render the current viewport.

AutoCAD 3D Tutorial

View rendered using a point and spotlight

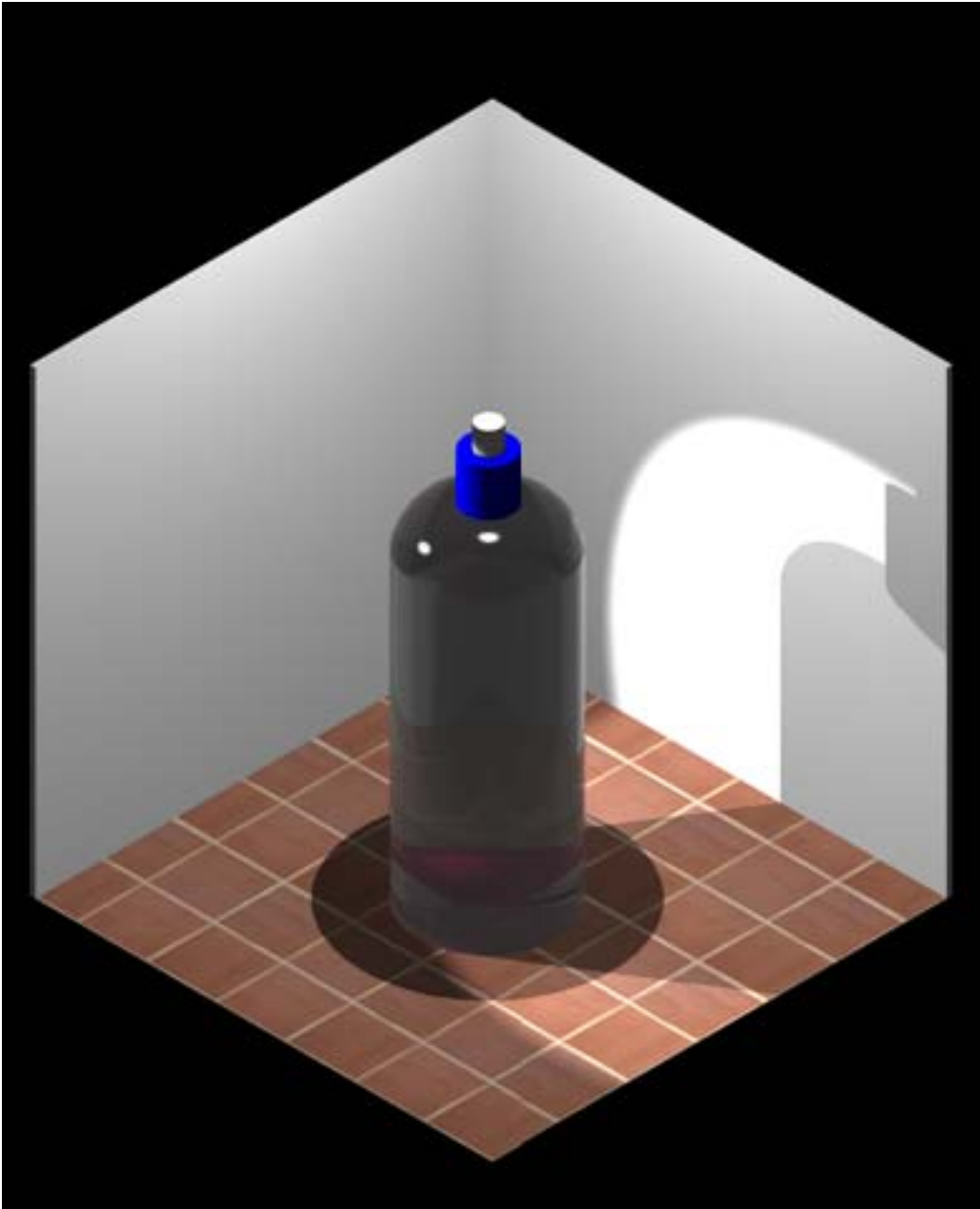

AutoCAD 3D Tutorial

20.4 Editing Lights with Light List

The lightlist command allows you to modify lights in a drawing. This includes turning lights off, deleting lights, or changing the properties of one or more lights.

1. Open a drawing with lights.
2. Choose **View, Render, Light, Lightlist**.
- or
3. Choose Lights in the Model from the lighting ribbon.

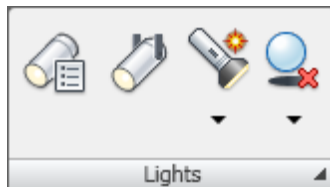

4. Type LIGHTLIST at the command prompt.
Command: **lightlist**

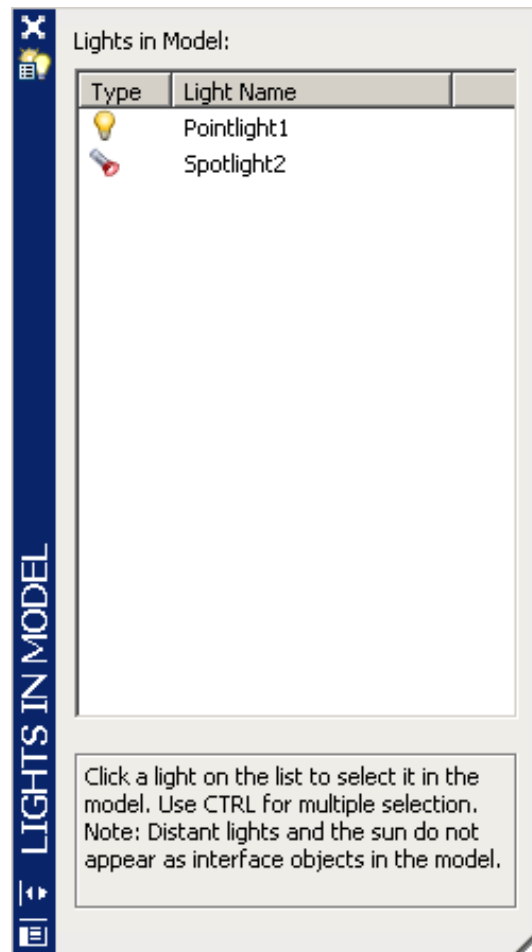

AutoCAD 3D Tutorial

4. Double-click one of the lights in the drawing to modify its properties.

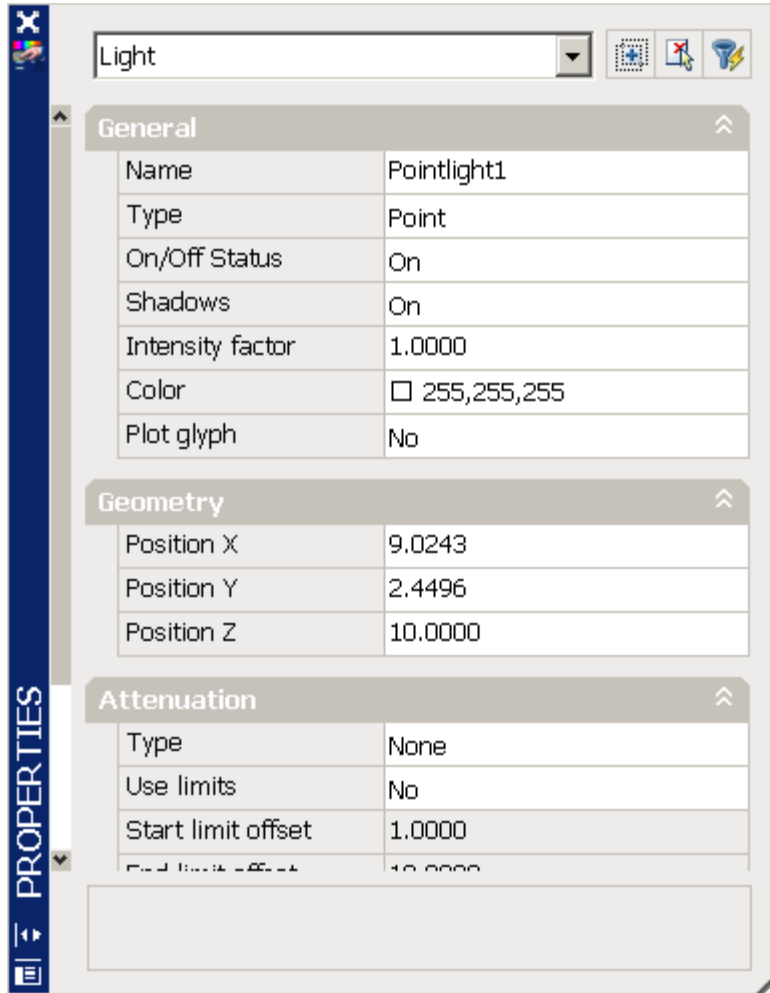





AutoCAD 3D Tutorial

20.5 Photometric Lights

For more precise control over lighting, you can use photometric lights to illuminate your model. Photometric lights use photometric (light energy) values that enable you to more accurately define lights as they would be in the real world. You can create lights with various distribution and color characteristics, or import specific photometric files available from lighting manufacturers.

Photometric lights can use manufacturers' IES standard file format. By using manufacturers' lighting data, you can visualize commercially available lighting in your model. Then you can experiment with different fixtures, and by varying the light intensity and color temperature, you can design a lighting system that produces the results you want.

1. Open a drawing with lights.
2. Type LIGHTLIST to see the current lights in the drawing.

Lights in Model:	
Type	Light Name
	Lamp Spotlight
	Pointlight1
	Pointlight2
	Pointlight3
	Pointlight4

3. Render the viewport to see the current light settings with photometric lights off.

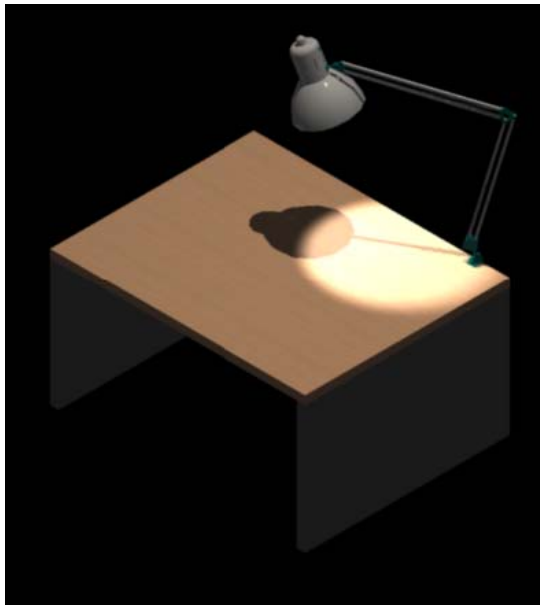

AutoCAD 3D Tutorial

4. Type LIGHTINGUNITS at the command prompt and set its value to 1 (on).

Command: lightingunits

Enter new value for LIGHTINGUNITS <0>: 1

5. Render the viewport to see the current light settings with photometric lights on.

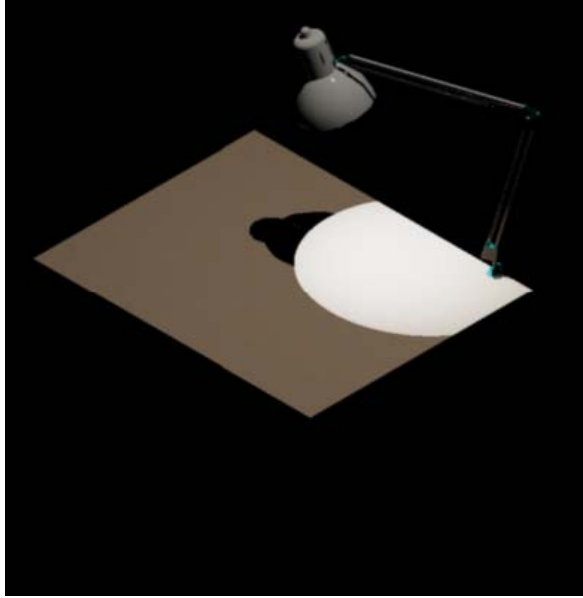

6. Type LIGHTLIST and double-click the Lamp Spotlight.
7. Change the lamp color to Halogen and the Candela intensity to 150.

Photometric properties ▲	
Lamp intensity	150.000 Cd
Resulting intensity	150.000 Cd
Lamp color	<input type="checkbox"/> Halogen
Resulting color	<input type="checkbox"/> 255,247,219

8. Render the viewport.

AutoCAD 3D Tutorial

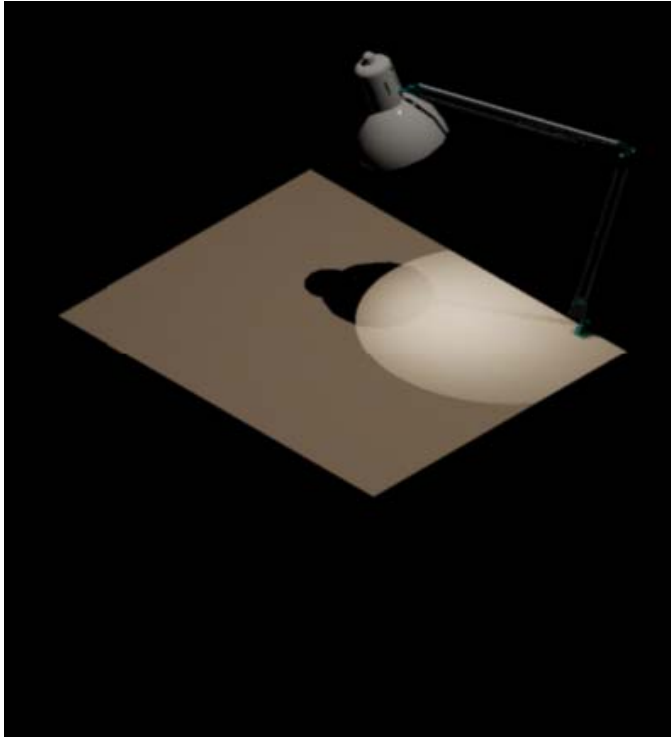

9. Practice changing other light's photometric properties.

AutoCAD 3D Tutorial

20.6 Lights Tool Palette

Default lights can be added to your drawing from the Tool Palette menus.

1. Press CTRL +3 to open the Tool Palettes.
2. Right click at the bottom of the palette tabs and choose Incandescent.

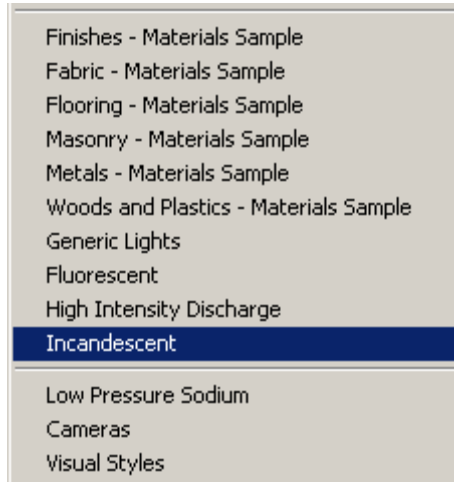

3. Right-click the 75 Watt bulb and choose properties.
4. Notice the photometric properties for this bulb.

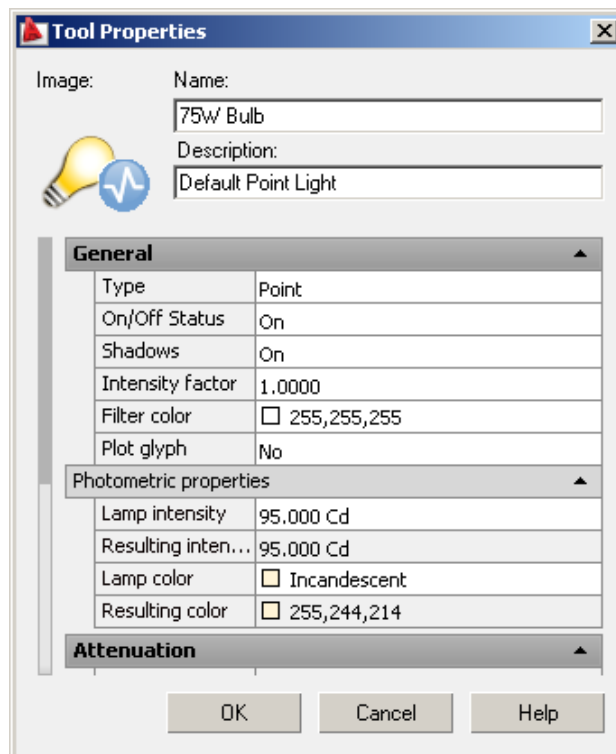

AutoCAD 3D Tutorial

20.7 Luminaries

To create realistic lighting in a drawing, you can embed photometric lights in blocks that also contain geometry.

Tool palettes of photometric lights provide easy access to photometric lighting bulbs, lamps, or webs. You can select from fluorescent, low pressure sodium, incandescent, and high intensity discharge types of lighting.

A luminary assembles a set of light objects into a light fixture. For example, you can create a set of lights to create a light over a dining area. You can select the photometric lights from the tool palettes, position them within a 3D representation of the light, and create a block of the light objects and the 3D representation of the light to create the light fixture with photometric properties.

1. Open a drawing with photometric lights and a light fixture.
2. Create a block of the light fixture made up of the lights and fixture.
3. Insert in the drawing and render.

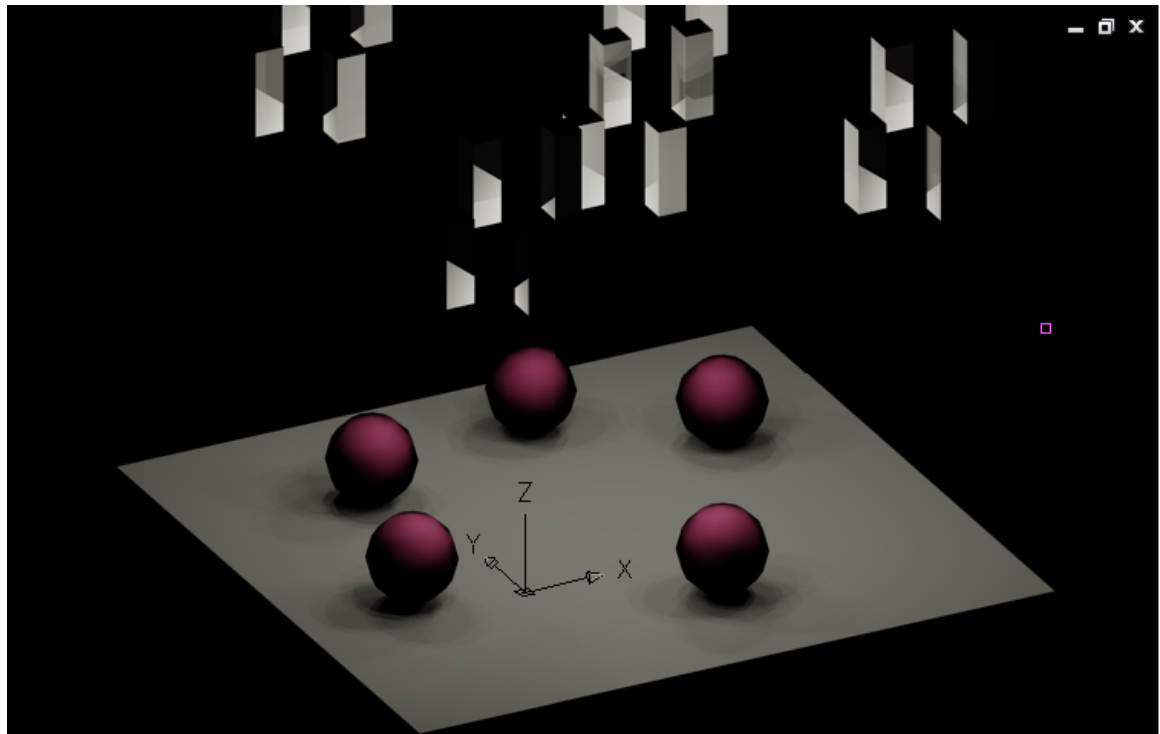

AutoCAD 3D Tutorial

20.8 Distant Lights

A distant light emits uniform parallel light rays in one direction only. You specify a FROM point and a TO point anywhere in the viewport to define the direction of the light. There is no light glyph to represent a distant light in your drawing.

1. Open a drawing with 3D objects and display in a 3D view.
2. Choose **View, Render, Light, New Distant Light**.

or

3. Type DISTANTLIGHT at the command prompt.

Command: **distantlight**

Specify light direction FROM <0,0,0> or [Vector]: **.XY**

of **MID P1**

of (need Z): **5**

Specify light direction TO <1,1,1>: **.XY**

of **MID P2**

of (need Z): **5**

Enter an option to change

[Name/Intensity/Status/shadoW/Color/eXit] <eXit>: **enter**

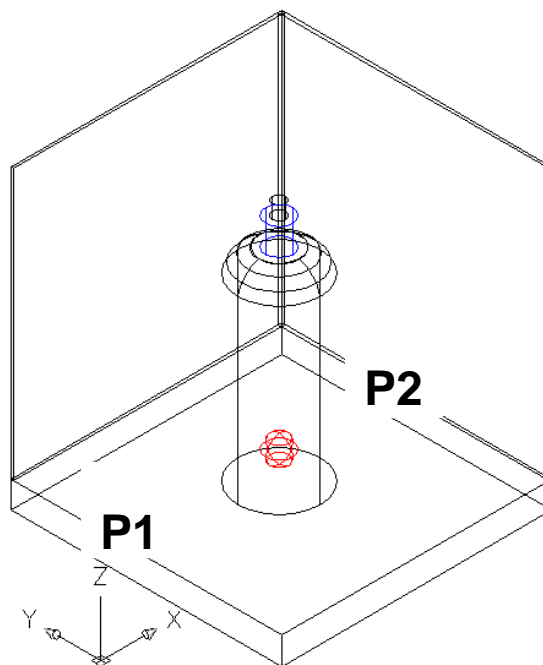

AutoCAD 3D Tutorial

View rendered using a point and spotlight

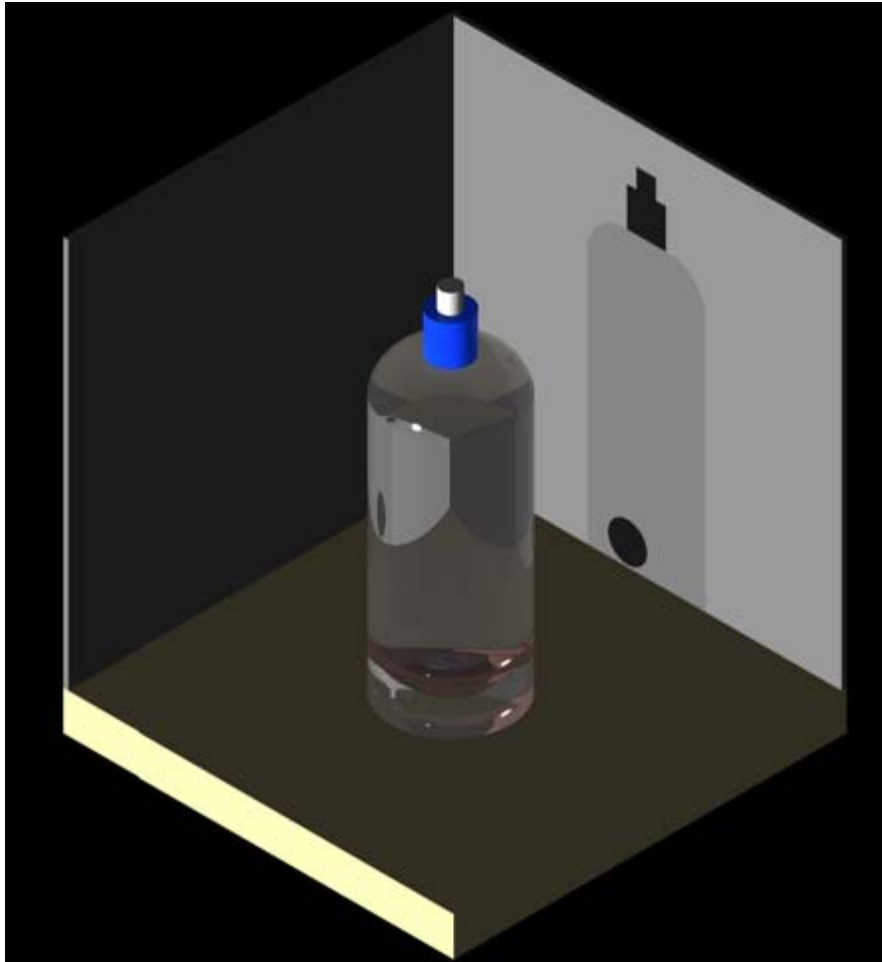

20.9 Other Lights

Weblights

Photometric weblights provide real-world light distribution.

A photometric weblight (web) is a 3D representation of the light intensity distribution of a light source. Photometric weblights can be used to represent anisotropic (non-uniform) light distributions derived from data provided by manufacturers of real-world lights. This gives a far more precise representation of the rendered light than either spot or point lights are capable of.

This directional light distribution information is stored in a photometric data file in the IES format using the IES LM-63-1991 standard file format for photometric data. You can load photometric data files provided by various manufacturers under the Photometric Web panel in the Properties palette for the light. The light icon represents the photometric web you select.

Light that uses a photometric web can be added to a drawing by entering the commands `WEBLIGHT` and `FREEWEB` at the command prompt. A weblight targets an object whereas a freeweb light does not.

Target Point Lights

You create a target point light with the `TARGETPOINT` command. The difference between the target point light and a point light is the additional target properties that are available. A target light can be pointed to an object. A target point light can also be created from a point light by changing the target property of the point light from No to Yes.

AutoCAD 3D Tutorial

20.10 Geographic Locations

Specifies the latitude and longitude of a location for the sunlight.

1. Open a drawing with lights.
2. Choose **View, Render, Light, Geographic Location**.
or
3. Type GEOGRAPHICLOCATION at the command prompt.
Command: **geographiclocation**
4. Choose Enter the location values from the following dialog box.

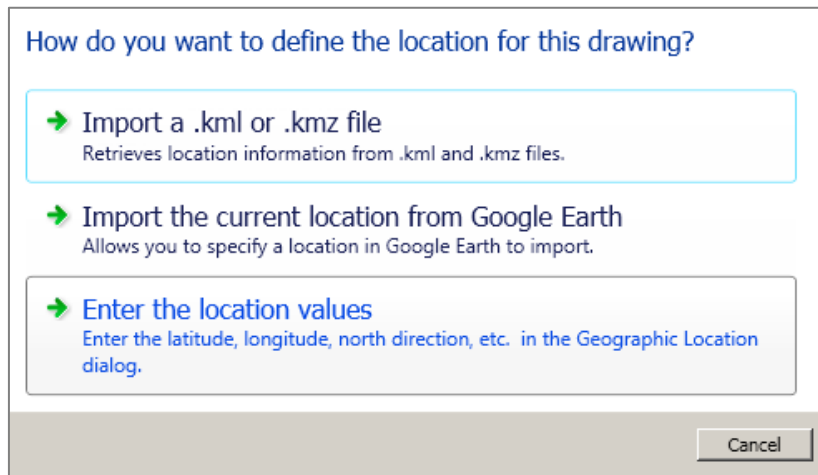

5. Click the Use map...button.

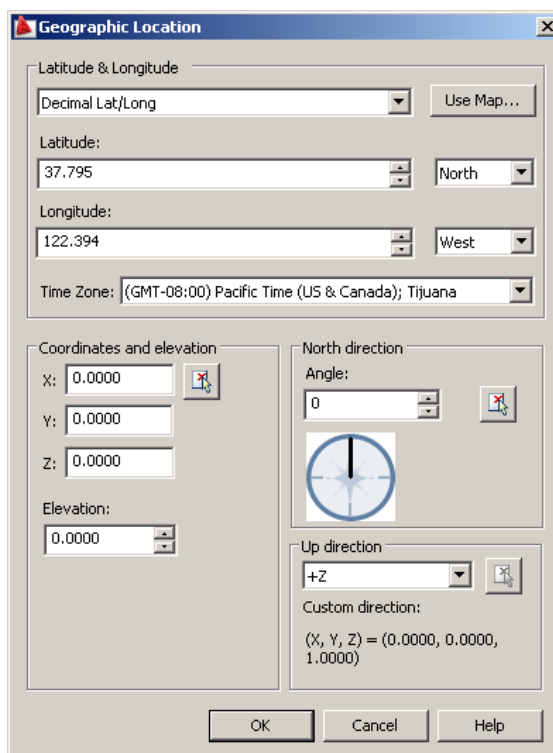

AutoCAD 3D Tutorial

6. Choose Washington, D.C from the location dialog box.

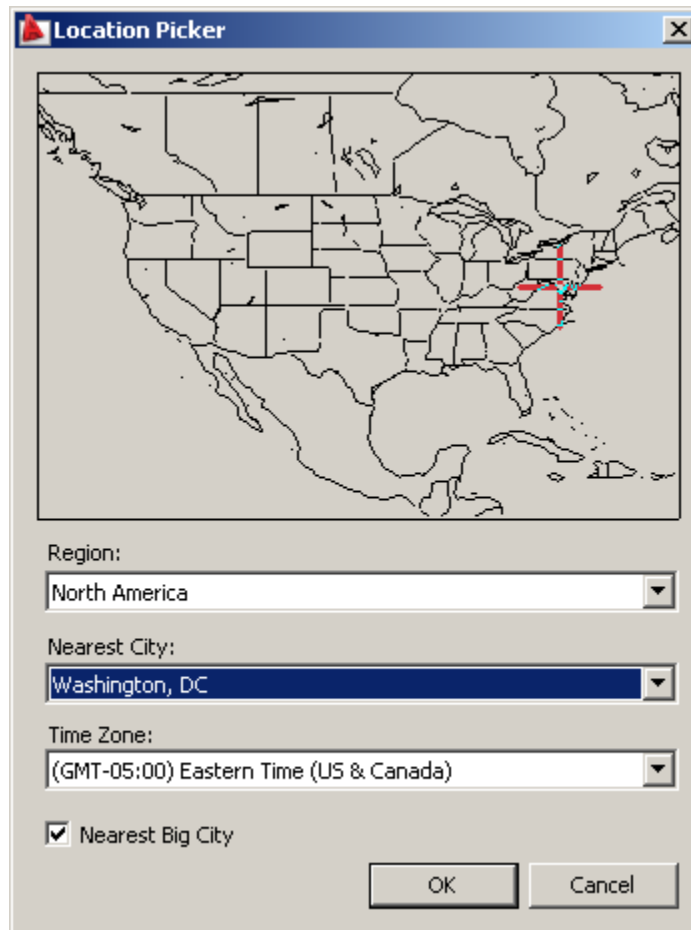

6. Accept the updated time zone settings.

AutoCAD 3D Tutorial

20.11 Sun Properties

1. Open a drawing with a geographic location identified.
2. Choose **View, Render, Light, Sun Properties**.
or
3. Type SUNPROPERTIES at the command prompt.
Command: **sunproperties**
4. From the Sun Properties dialog box, click the Status dropdown and click **ON**.
5. Change the date to **November 4, 2008**.
6. Change other properties as desired and render the model. Repeat for **January 20, 2009**.

General	
Status	On
Intensity Factor	1.0000
Color	<input type="checkbox"/> 255,255,255
Shadows	On

Sun Angle Calculator	
Date	11/4/2008
Time	3:00 PM
Daylight Saving	No
Azimuth	229
Altitude	20
Source Vector	-0.7049,-0.6220,0...

Rendered Shadow Details

Geographic Location	
City:	Washington, DC
Time Zone:	(GMT-05:00) Eastern Time (US & Canada)
Latitude:	38.9051
Latitude Direction:	North
Longitude:	-77.0162
Longitude Direction:	West

AutoCAD 3D Tutorial

US Capitol Building rendered on November 4, 2008

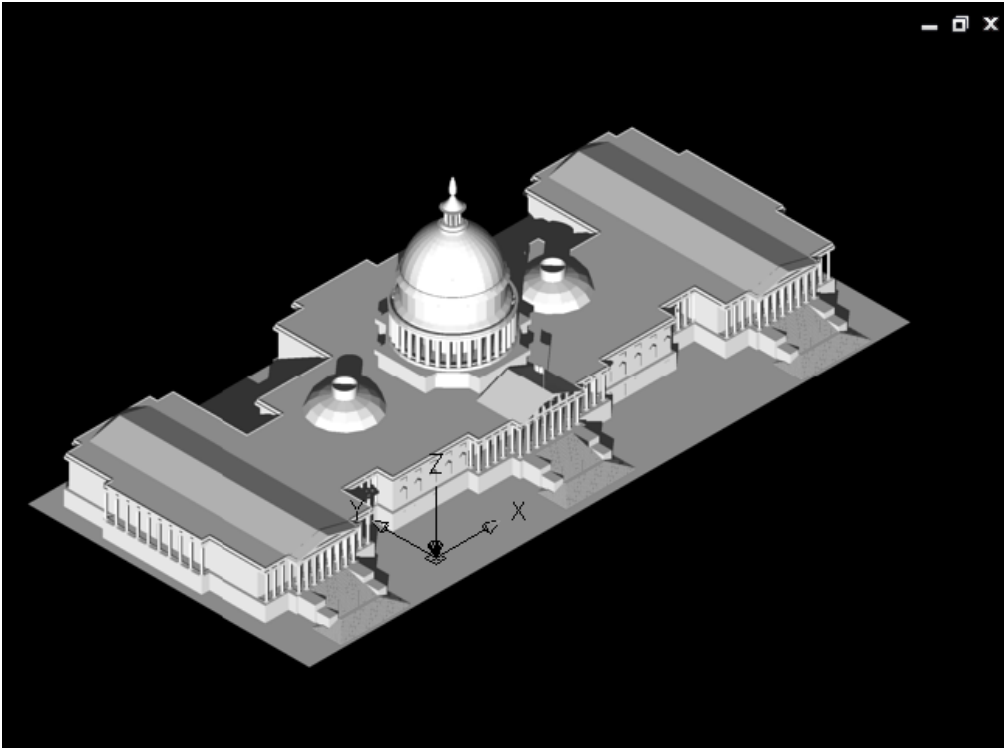

US Capitol Building rendered on January 20

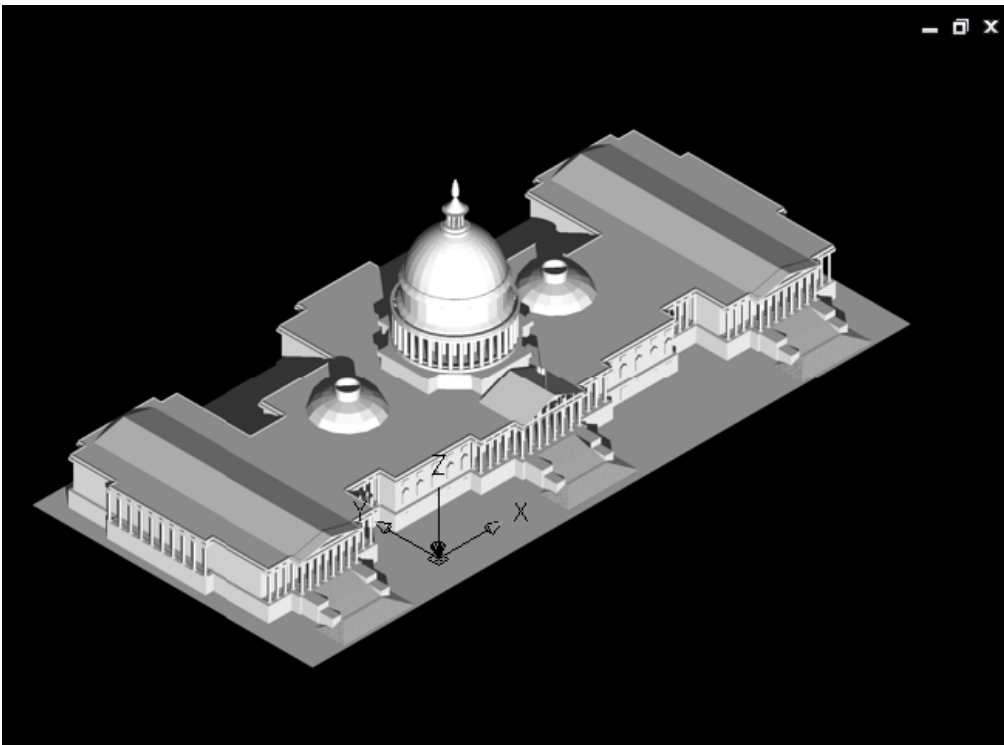

**AutoCAD 3D – Chapter 21
Render Environments and
Background**

AutoCAD 3D Tutorial

21.1 Render Environment

You can use environmental features to set up atmospheric effects or background images.

1. Open a drawing with 3D objects and display in a 3D view.
2. Choose **View, Render, Advanced Render Environment...**

or

3. Type RENDERENVIRONMENT at the command prompt.

Command: **renderenvironment**

Fog / Depth Cue ▲	
Enable Fog	Off
Color	■ 128,128,128
Fog Background	Off
Near Distance	0.0000
Far Distance	100.0000
Near Fog Perc...	0.0000
Far Fog Perce...	100.0000

AutoCAD 3D Tutorial

21.2 Solid Background

A background is a backdrop that displays behind your model. Backgrounds can be a single color, a multi-color gradient, or a bitmap image.

1. Open a drawing with 3D objects and display in a 3D view.
2. Choose **View, Named Views**.
or
3. Type VIEW at the command prompt.
Command: **view**
4. Choose **New...**
5. Type a name for your new view.
6. Click the drop down box under background and choose Solid.
7. Choose a color for your solid background.

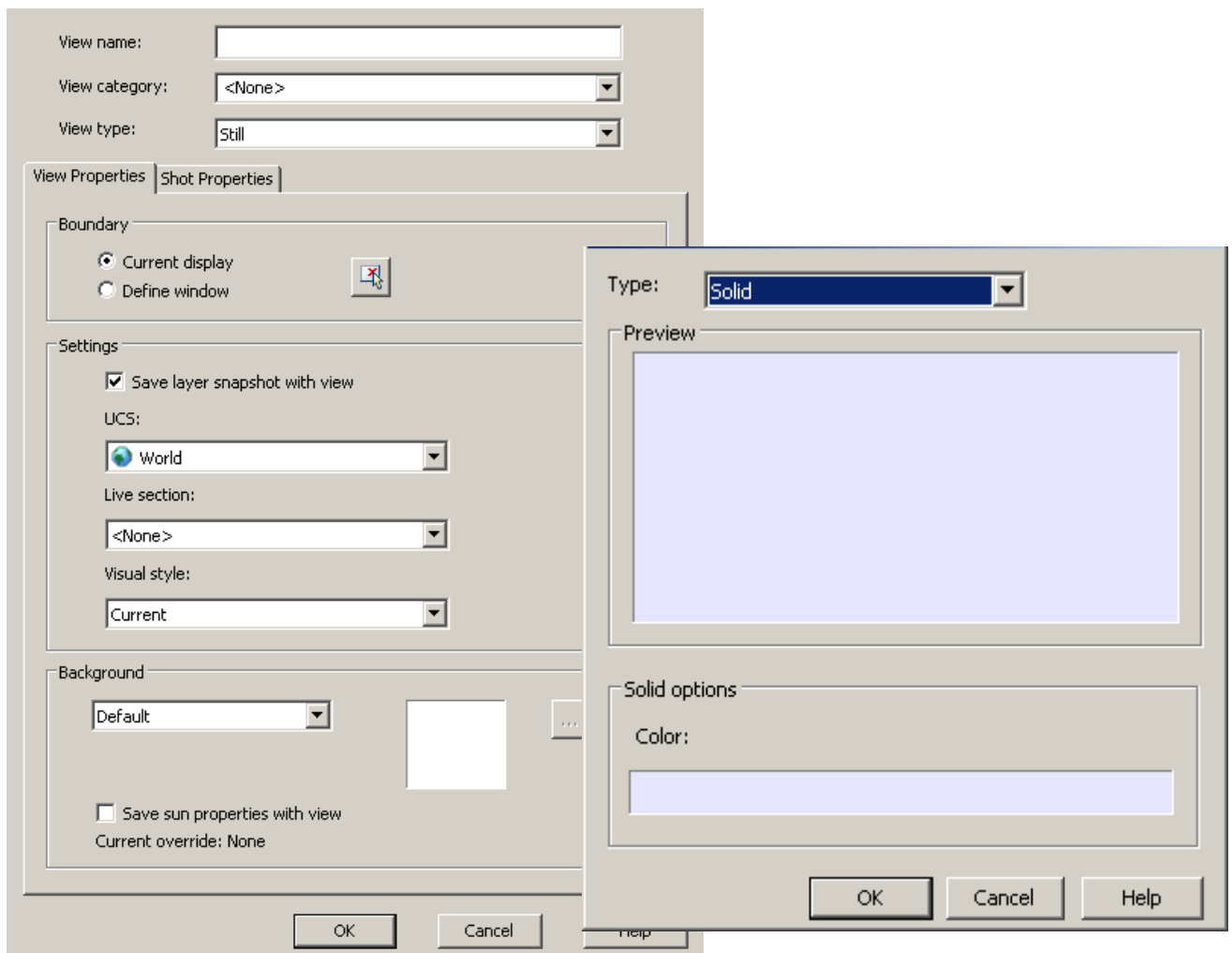

AutoCAD 3D Tutorial

21.3 Gradient Environment

1. Open a drawing with 3D objects and display in a 3D view.
2. Choose **View, Named Views**.
or
3. Type VIEW at the command prompt.
Command: **view**
4. Choose **New...**
5. Type a name for your new view.
6. Click the check box beside background.
7. Choose the dropdown option for background type and choose gradient.
8. Choose colors for your gradient background.

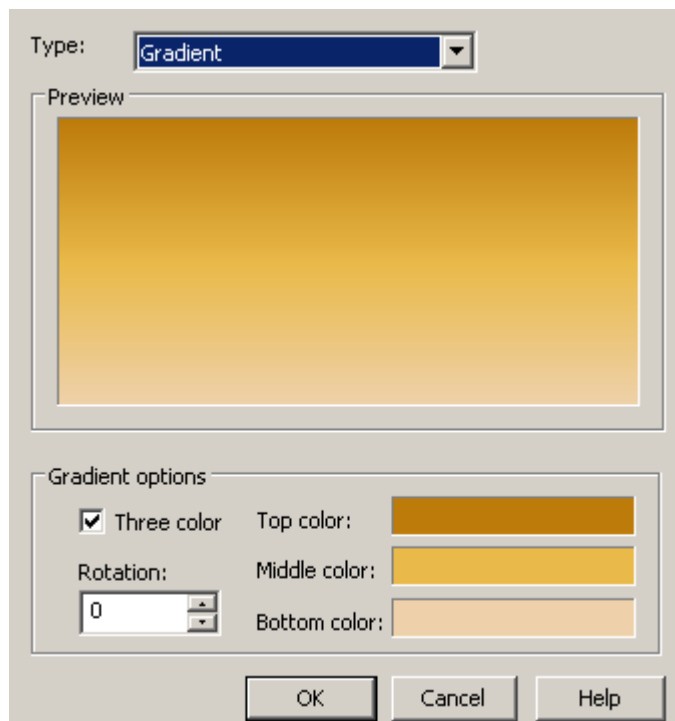

AutoCAD 3D Tutorial

21.4 Image Background

1. Open a drawing with 3D objects and display in a 3D view.
2. Choose **View, Named Views**.
or
3. Type VIEW at the command prompt.
Command: **view**
4. Choose **New...**
5. Type a name for your new view.
6. Click the check box beside background.
7. Choose the dropdown option for background type and choose image.
8. Click the Browse button and choose an image for your background.

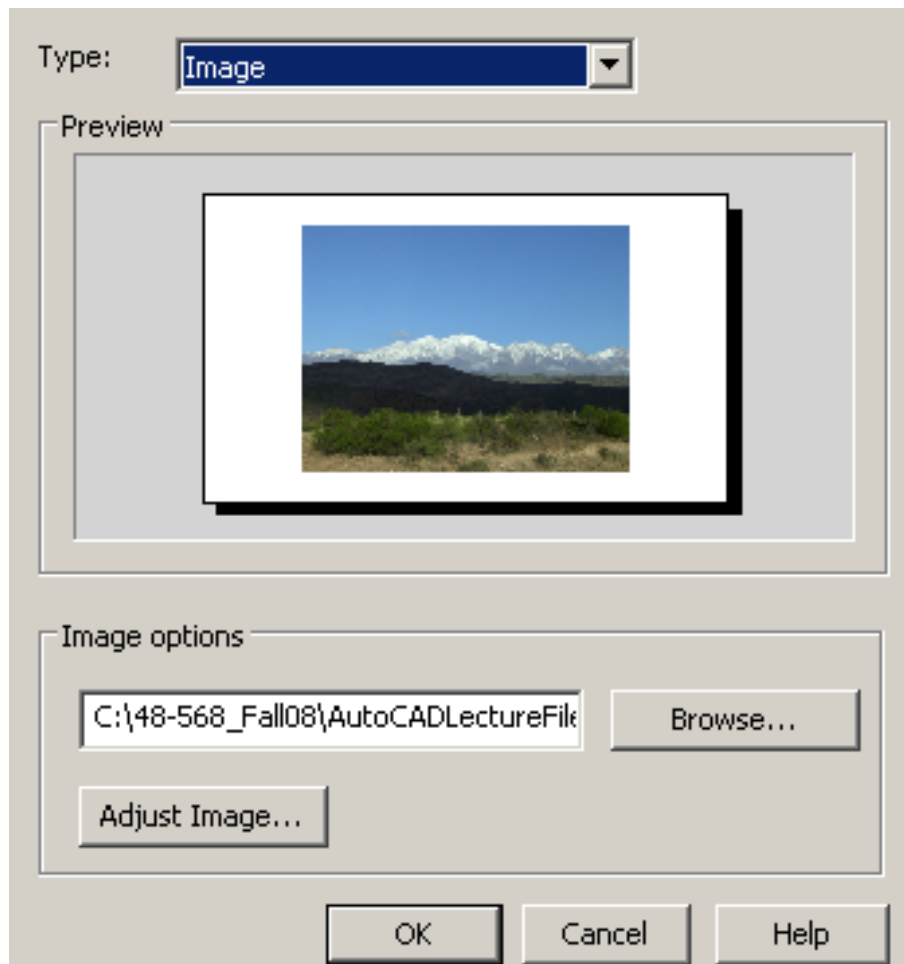

AutoCAD 3D – Chapter 22
Advanced Render
Commands

AutoCAD 3D Tutorial

22.1 Materials

Contains settings that affect how materials are handled by the renderer.

Apply Materials

Applies the surface materials that you define and attach to an object in the drawing. If Apply Materials is not selected, all objects in the drawing assume the color, ambient, diffuse, reflection, roughness, transparency, refraction, and bump map attribute values defined for the GLOBAL material.

Texture Filtering

Specifies how texture maps are filtered.

Force 2-Sided

Controls if both sides of faces are rendered.

1. Open a drawing with 3D objects and display in a 3D view.
 2. Choose View, Render, Advanced Render Settings...
- or
3. Type RPREF at the command prompt.

Command: **rpref**

Materials	
Apply materials	On
Texture filtering	On
Force 2-sided	On

AutoCAD 3D Tutorial

22.2 Sampling

Controls how the renderer performs sampling.

1. Type RPREF at the command prompt.

Command: **rpref**

Sampling	
Min samples	1
Max samples	16
Filter type	Mitchell
Filter width	4.0000
Filter height	4.0000
Contrast color	0.0500, 0.0500, 0.0500, 0.0500
Contrast red	0.0500
Contrast blue	0.0500
Contrast green	0.0500
Contrast alpha	0.0500

Min Samples

Sets the minimum sample rate. The value represents the number of samples per pixel. A value greater than or equal to 1 indicates that one or more samples are computed per pixel. A fractional value indicates that one sample is computed for every N pixels (for example, 1/4 computes a minimum of one sample for every four pixels). Default=1/4.

Max Samples

Sets the maximum sample rate. If neighboring samples find a difference in contrast that exceeds the contrast limit, the area containing the contrast is subdivided to the depth specified by Maximum. Default=1.

The values of the Min Samples and Max Samples lists are "locked" together so that the value of Min Samples can't exceed the value of Max Samples. An error dialog box is displayed if the Min Samples value is greater than the Max Samples value.

AutoCAD 3D Tutorial

Filter Type

Determines how multiple samples are combined into a single pixel value. The filter types are:

Box. Sums all samples in the filter area with equal weight. This is the quickest sampling method.

Gauss. Weights the samples using a Gauss (bell) curve centered on the pixel.

Triangle. Weights the samples using a pyramid centered on the pixel.

Mitchell. Weights the samples using a curve (steeper than Gauss) centered on the pixel.

Lanczos. Weights the samples using a curve (steeper than Gauss) centered on the pixel, diminishing the effect of samples at the edge of the filter area.

Filter Width and Filter Height

Specifies the size of the filtered area. Increasing the value of Filter Width and Filter Height can soften the image; however, it will increase rendering time.

Contrast Color

Clicking [...] opens the Select Color dialog box where you interactively specify the R,G,B threshold values.

Contrast Red, Blue, Green

Specifies the threshold values for the red, blue, and green components of samples. These values are normalized, and range from 0.0 to 1.0, where 0.0 indicates the color component is fully unsaturated (black, or 0 in eight-bit encoding) and 1.0 indicates the color component is fully saturated (white, or 255 in eight-bit encoding).

Contrast Alpha

Specifies the threshold value for the alpha component of samples. This value is normalized, and ranges from 0.0 (fully transparent, or 0 in eight-bit encoding) to 1.0 (fully opaque, or 255 in eight-bit encoding).

AutoCAD 3D Tutorial

22.3 Shadows

Contains settings that affect how shadows appear in the rendered image.

1. Type RPREF at the command prompt.

Command: **rpref**

Shadows	
Mode	Simple
Shadow map	Off
Sampling Multiplier	1

Enable

Specifies if shadows are computed during rendering.

Mode

The shadow mode can be Simple, Sort, or Segments.

Simple. Generates shadow shaders in a random order.

Sort. Generates shadow shaders in order, from the object to the light.

Segments. Generates shadow shaders in order along the light ray from the volume shaders to the segments of the light ray between the object and the light.

Shadow Map

Controls if shadow mapping is used to render shadows. When on, the renderer renders shadow-mapped shadows. When off, all shadows are ray-traced.

Sampling Multiplier

Globally limits shadow sampling for area lights. This is part of the rendering preset data. This allows draft and low quality presets to reduce area light sampling. It's effect is to modulate the inherent sampling frequency specified for each light. The default value=1 for new presets. Values are 0, 1/8, 1/4, 1/2, 1, 2. Draft: 0; Low:1/4; Med:1/2; High:1; Presentation:1.

AutoCAD 3D Tutorial

22.4 Ray Tracing

Contains settings that affect the shading of a rendered image.

1. Type RPREF at the command prompt.

Command: **rpref**

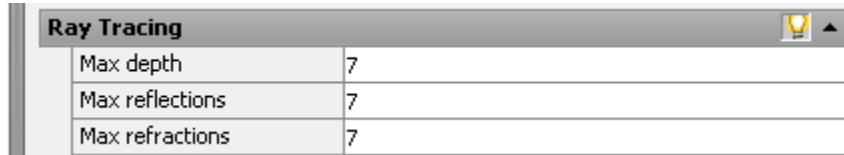

Ray Tracing	
Max depth	7
Max reflections	7
Max refractions	7

Enable

Specifies if ray tracing should be performed when shading.

Max Depth

Limits the combination of reflection and refraction. Tracing of a ray stops when the total number of reflections and refractions reaches the maximum depth. For example, if Max Depth equals 3 and the two trace depths each equal the default value of 2, a ray can be reflected twice and refracted once, or vice versa, but it cannot be reflected and refracted four times.

Max Reflections

Sets the number of times a ray can be reflected. At 0, no reflection occurs. At 1, the ray can be reflected once only. At 2, the ray can be reflected twice, and so on.

Max Refractions

Sets the number of times a ray can be refracted. At 0, no refraction occurs. At 1, the ray can be refracted once only. At 2, the ray can be refracted twice, and so on.

AutoCAD 3D Tutorial

22.5 Illumination

Affects how your scene is illuminated.

1. Type RPREF at the command prompt.

Command: **rpref**

Indirect Illumination	
Global Illumination 	
Photons/sample	500
Use radius	Off
Radius	1.0000
Max depth	5
Max reflections	5
Max refractions	5
Final Gather	
Mode	Auto
Rays	500
Radius mode	Off
Max radius	1.0000
Use min	Off
Min radius	0.1000
Light Properties	
Photons/light	10000
Energy multiplier	1.0000

Enable

Specifies if lights should cast indirect light into the scene.

Photons/Samples

Sets how many photons are used to compute the intensity of the global illumination. Increasing this value makes global illumination less noisy but also more blurry. Decreasing this value makes global illumination more noisy but less blurry. The larger the Samples value, the greater the rendering time.

Use Radius

Determines the size of photons. When on, the spinner value sets the size of photons. When off, each photon is calculated to be 1/10 of the radius of the full scene.

AutoCAD 3D Tutorial

Radius

Specifies the area within which photons will be used when illuminance is computed.

Max Depth

Limits the combination of reflection and refraction. Reflection and refraction of a photon stop when the total number of both equals the Max Depth setting. For example, if Max Depth equals 3 and the trace depths each equal 2, a photon can be reflected twice and refracted once, or vice versa, but it can't be reflected and refracted four times.

Max Reflections

Sets the number of times a photon can be reflected. At 0, no reflection occurs. At 1, the photon can be reflected once only. At 2, the photon can be reflected twice, and so on.

Max Refractions

Sets the number of times a photon can be refracted. At 0, no refraction occurs. At 1, the photon can be refracted once only. At 2, the photon can be refracted twice, and so on.

AutoCAD 3D Tutorial

22.6 Diagnostic

Helps you understand why the renderer is behaving in a certain way.

1. Type RPREF at the command prompt.

Command: **rpref**

Diagnostic	
Visual	
Grid	Off
Grid size	10.0000
Photon	Off
Samples	Off
BSP	Off

Grid: Renders an image that shows the coordinate space of objects, the world, or camera.

Object. Shows local coordinates (UVW). Each object has its own coordinate space.

World. Shows world coordinates (XYZ). The same coordinate system applies to all objects.

Camera. Shows camera coordinates, which appear as a rectangular grid superimposed on the view.

Grid Size:

Sets the size of the grid.

Photon

Renders the effect of a photon map. This requires that a photon map be present. If no photon map is present, the Photon rendering looks just like the nondiagnostic rendering of the scene: the renderer first renders the shaded scene, then replaces it with the pseudocolor image.

Density. Renders the photon map as it is projected into the scene. High density is

AutoCAD 3D Tutorial

displayed in red, and lower values render in increasingly cooler colors.

Irradiance. Similar to the Density rendering, but shades the photons based on their irradiance. The maximum irradiance is rendered in red, and lower values render in increasingly cooler colors.

BSP

Renders a visualization of the parameters used by the tree in the BSP ray-trace acceleration method. If a message from the renderer reports excessively large depth or size values, or if rendering seems unusually slow, this can help you locate the problem.

Depth. Shows the depth of the tree, with top faces in bright red, and increasingly deep faces in increasingly cool colors.

Size. Shows the size of leaves in the tree, with differently sized leaves indicated by different colors.

AutoCAD 3D Tutorial

22.7 Processing

1. Type RPREF at the command prompt.

Command: **rpref**

Processing	
Tile size	32
Tile order	Hilbert
Memory limit	1048

Tile Size

Determines the tile size for rendering. To render the scene, the image is subdivided into tiles. The smaller the tile size, the more image updates are generated during rendering. When the tile size is reduced, the number of image updates increases, meaning that a rendering take longer to complete. If the tile size is increased, fewer image updates occur and the rendering takes less time to complete.

Tile Order

Specifies the method used (render order) for tiles as an image is rendered. You can choose a method based on how you prefer to see the image appear as it renders in the Render Window.

Hilbert. Next tile to be rendered is based on the cost of switching to the next one.

Spiral. Tiles are rendered beginning at the center of the image, and spiral outward.

Left to Right. Tiles are rendered in columns, from bottom to top, left to right.

Right to Left. Tiles are rendered in columns, from bottom to top, right to left.

Top to Bottom. Tiles are rendered in rows, from right to left, top to bottom.

Bottom to Top. Tiles are rendered in rows, from right to left, bottom to top.

Memory Limit

Determines the memory limit for rendering. The renderer keeps a count of the memory it uses at render time. If the memory limit is reached, the geometry for some objects is discarded in order to allocate memory for other objects.